



2025



**RACKTECH 2.0**

page 38



**X82**

page 44 to 45



**MKII Compact Sail**

page 283



**UJS-B  
INTEGRA with bow thruster**

page 111 to 154



# HIGHLIGHTS



INTEGRA FOR INBOARD

page 169-180



B120

page 300 to 301



V19

page 184



MANNA

page 189



GALLINARA

page 193

# HIGHLIGHTS



GIGLIO

page 196



V76

page 207



V75

page 198



VENDRAMIN

page 214 to 215



BARBARIGO

page 218 to 219



KEYWEST PCBCK

page 270 to 271



**ULTRAFLEX GROUP**

**90** years  
1935-2025



**UFLEX USA Inc**  
Driving the future of boating



 **ULTRAFLEX S.p.a**  
Steering and control systems for pleasure boats.

 **UFLEX S.r.l**  
Worldwide distribution of marine accessories

 **UFLEX - Energy Division**  
Systems and accessories for alternative energy applications

 **ULTRAFLEX CONTROL SYSTEMS S.r.l**  
Window and skylight remote controls. Innovative LED sign technology.

 **INDUSTRIA di LEVI S.r.l**  
Mechanical remote controls in the industrial field



## MANAGEMENT SYSTEM

The Ultraflex and Uflex Management Systems involve all the company resources and processes starting from the design, in order to:

- Define and comply with the customer requirements
- Set up the actions to maintain and improve the quality standards constantly
- Pursue a continuous process improvement to meet the market needs, through research, innovation and developing products and processes.
- Maintain and verify conformity with ABYC requirements.
- Pursuing environmental protection, including pollution and continuous improvement aimed at environmental performance
- Constantly test the products to verify their conformity with the 2013/53 EU and ABYC (American Boat and Yacht Council) requirements.





**[www.uflexusa.com](http://www.uflexusa.com)**

- Technical Service ph. 941.351.2628
- Sales ph. 941.351.2628
- Administration ph. 941.351.2628

## **CORPORATE INFORMATION**

Established in 1989 Uflex USA is a leader in steering and control systems for the marine industry. With full manufacturing capabilities in Sarasota, Florida, Uflex USA can support all sectors of the marine industry regardless of the volume and/or product requirements. As an affiliate of the Ultraflex Group, Uflex USA has tremendous resources to draw upon for new product development in hydraulics, electronics and many other technologies.

Innovative product design and unparalleled dedication to quality, customer service and products continue to be the cornerstone of Uflex USA's growth. Today our products can be found as originally installed equipment on many of the most widely known and respected boat brands in the world. Aftermarket parts can be sourced from trained and experienced distributor network throughout North, South and Central America.

Our dedication to providing the highest quality products and service is only matched by our commitment to developing new products employing the latest materials and technology to enhance our customer's boating experience. From steering wheels to sophisticated electronic steering system and controls, Uflex USA has everything you need to make sure that your boat looks and performs its best for many, many years.

**UFLEX USA Inc.**  
**6442 PARKLAND DRIVE**  
**SARASOTA, FLORIDA 34243 - USA**  
**PH. (941) 351-2628**  
**[www.uflexusa.com](http://www.uflexusa.com)**  
**email: [sales@uflexusa.com](mailto:sales@uflexusa.com)**



**UFLEX USA® - Limited Warranty**

*page 10 to 11*

**SELECTING A STEERING SYSTEM**

*page 12 to 14*



**MECHANICAL STEERING SYSTEMS**

*page 15 to 38*

**Mechanical rotary steering systems**

*page 16 to 25*

**Rack and pinion mechanical steering systems**

*page 26 to 31*

**NaviTech™ steering system**



*page 32 to 33*

**Accessories and packaged  
mechanical steering systems**

*page 34 to 38*



**OUTBOARD AND STERNDRIVE  
HYDRAULIC STEERING SYSTEMS**

*page 39 to 106*

**Selecting an outboard hydraulic  
steering system - cross reference**

*page 40 to 41*

**Steering wheel position adjustment systems  
(Tilt mechanisms)**

*page 44 to 45*

**Standard outboard  
hydraulic steering systems**

*page 46 to 61*

**Packaged outboard  
hydraulic steering systems**

*page 62 to 63*

***SILVERSTEER*™ High performance outboard  
hydraulic steering systems**

*page 64 to 74*



**Bass Boat high performance outboard hydraulic steering systems** *page 75 to 79*

**Tie bars for outboard engines** *page 78 to 89*

** Power assisted outboard steering systems** *page 90 to 97*

**Sterndrive steering systems** *page 98 to 99*

**Accessories and fittings cross reference guide** *page 100 to 105*

**BubbleBuster™ Automatic filling and purging system** *page 106*



**ZERO TORQUE FEEDBACK TILLER STEERING SYSTEMS** *page 107 to 110*



**INTEGRA™ - OUTBOARD ELECTRONIC POWER STEERING SYSTEMS** *page 111 to 154*

**INTEGRA EPS and INTEGRA JS Electronic steering systems** *page 112 to 140*

**INTEGRA equipped with UPA123 actuator** *page 141 to 154*



**INBOARD HYDRAULIC STEERING SYSTEMS** *page 155 to 168*



**INTEGRA™ - INBOARD ELECTRONIC POWER STEERING SYSTEMS** *page 169 to 180*



## STEERING WHEELS

*page 181 to 208*

**Composite steering wheels**

*page 182 to 183*

**Soft touch grip steering wheels**

*page 184 to 186*

**Polyurethane and wood grip steering wheels**

*page 187 to 208*



## “VERO VOLANTE ITALIANO” STEERING WHEELS

*page 209 to 278*

**Polyurethane,  
vinyl or leather grip steering wheels**

*page 210 to 257*

**Stainless steel grip steering wheels**

*page 258 to 267*

**Fiber carbon grip steering wheel**

*page 268 to 271*

**QDH - Quick disconnect hub, wheel  
accessories and accessories application chart**

*page 272 to 275*

**Paddle Trim and wheel maintenance**

*page 276 to 278*



***Power A Mark II™***

## ELECTRONIC CONTROL SYSTEM

*page 279 to 290*



## MECHANICAL AND HYBRID CONTROL SYSTEMS

*page 291 to 328*

**Engine control box selection**

*page 292 to 293*

**Mechanical and hybrid  
Single lever engine controls**

*page 294 to 315*

**Two-lever engine controls and  
accessories for control boxes**

*page 316 to 323*

**Engine control cables and accessories**

*page 324 to 328*

## SPARE PARTS

*page 329 to 332*



## UCS® ELECTROMECHANICAL HATCH LIFTERS

*page 333 to 336*



## TRIM TABS

*page 337 to 348*



## MARINE AIR CONDITIONING SYSTEMS

*page 349 to 353*

*Uflex USA Inc. declines any liability for possible mistakes in this catalogue due to printing errors. Ultraflex S.p.A. reserves the right to make those modifications that are considered to be suitable for its products.*

*Publishing rights, trade marks, part numbers and photographs of the Ultraflex and Uflex products present on this catalog are Ultraflex and Uflex property and all rights are reserved.*

*The descriptions and guidelines shown in this catalog should be used as general reference only. For any further information please contact our Technical Service.*

# UFLEX USA INC. LIMITED WARRANTY

- 1. Two Year Limited Warranty.** Uflex USA Inc. warrants that all products manufactured by Uflex USA Inc or Ultraflex S.p.A. and sold by Uflex USA to the retail purchaser ("Purchaser") that for two (2) years after the date of manufacture to be free from defects due to material or workmanship, subject to the exclusions below. Improper installation VOIDS this warranty. Installation should only be attempted by a trained and qualified technician.
- 2. Exclusions.** This limited warranty does not cover and does not extend to any of the following:
  - (a)** Failure caused by normal wear and tear, climatic conditions, misuse, neglect, lack of proper maintenance, accident, fire or other casualty damage, racing, overloading, negligence, modification, beaching or grounding of vessel, collision, impact, towing, acts of war or hostilities;
  - (b)** components not manufactured by Uflex USA Inc., or its affiliates;
  - (c)** cost of removal or reinstallation of any component (including components manufactured by Uflex USA Inc.), or disassembly and reassembly of the unit containing the component;
  - (d)** components not manufactured by Uflex USA Inc. or Ultraflex S.p.A., whether or not warranted by the other manufacturer.
  - (e)** any product which has not been properly installed.
- 3. Limitations. THE REPAIR OR REPLACEMENT OF DEFECTIVE PARTS SHALL BE PURCHASER'S SOLE AND EXCLUSIVE REMEDY AND UFLEX USA INC.'S SOLE AND EXCLUSIVE LIABILITY UNDER THIS WARRANTY. LABOR FOR REPLACEMENT IS NOT INCLUDED.** Uflex USA Inc.'s obligation under this warranty is limited to the repair or replacement (at Uflex USA Inc.'s sole election) of any covered item found to be defective, when delivered by Purchaser pursuant to written authorization and instructions from Uflex USA Inc., shipping prepaid to Uflex USA Inc.'s, plant or other designated repair facility. Repaired or replaced items are warranted as provided herein for the unexpired portion of the applicable warranty period.

**THIS WARRANTY, AND THE RIGHTS AND REMEDIES UNDER IT, IS EXCLUSIVE AND IS GIVEN IN PLACE OF ALL OTHER WARRANTIES, WHETHER EXPRESS OR IMPLIED, INCLUDING ANY IMPLIED WARRANTY OF MERCHANTABILITY OR FITNESS FOR PARTICULAR PURPOSE, WHETHER ARISING BY LAW, CUSTOM, CONDUCT OR USAGE OF TRADE. PURCHASER'S REMEDIES SHALL BE LIMITED AS STATED HEREIN AND UFLEX USA INC. SHALL NOT BE LIABLE FOR ANY INCIDENTAL, CONSEQUENTIAL OR INDIRECT DAMAGES OR LOSSES RESULTING FROM DEFECTS.**

**THE RETAIL SELLER IS NOT A CO-WARRANTOR AND IS NOT AUTHORIZED BY UFLEX USA INC. TO AMEND OR MODIFY THIS LIMITED WARRANTY IN ANY MANNER.**
- 4. Transferability of Warranty. This limited warranty may not be transferred to subsequent purchasers.**
- 5. Miscellaneous.** Uflex USA Inc. is an affiliate of Ultraflex S.p.A. Uflex USA, Inc., reserves the right to make changes in the design and construction of its products at any time, without notice and without any obligation to incorporate such changes into products of prior manufacture. This limited warranty applies to new components sold by Uflex USA Inc.. This limited warranty contains the entire agreement between Uflex USA Inc. and Purchaser and supersedes all prior agreements, discussions, negotiations, commitments and representations, whether oral or written, between them regarding Uflex USA Inc.'s warranty. If any provision of this limited warranty, or the application of it, is determined to be invalid or unenforceable for any reason, the remainder of this limited warranty and the application of it shall not be affected.
- 6. Power A Mark II™.** The "Power A Mark II™ - User and Installation Manual" describes activities, operations, technical specifications which must be followed during the installation and/or usage of the product, in order to keep a valid warranty. Descriptions and drawings in that manual are suitable to allow installation and use of the product to skilled persons. In case of doubt and/or for any information, please contact our Technical Service.

**All communications and notices from Purchaser regarding this limited warranty should be sent to:**

**UFLEX USA INC.**

**6442 Parkland Drive**

**Sarasota, Florida 34243**

**(941) 351-2628.**

## CE CERTIFICATION

The **CE** Examination on the **ULTRAFLEX** steering systems has been carried out by an Institute certified by the European Commission. We kindly remind you that on the boats marked **CE** it is compulsory to install steering systems with components marked **CE** (see art. 4 and 5 of Directive **2013/53/EU**).

### **ULTRAFLEX mechanical, hydraulic and electronic steering systems**

are all marked **CE** in compliance with the EEC Directive and marked **UKCA** in compliance with UK RCR (Recreational Craft Regulations) 2017, in conformity with the following harmonised standards:

- ISO 8848 for mechanical steering systems and steering cables
- ISO 23411 for steering wheels
- ISO 10592 for hydraulic steering systems
- ISO 25197 for Integra electronic steering systems
- 

### **Electronic system components and engine start-up protection devices**

are all marked **CE** in compliance with the EEC Directive EMC 2014/30/EU (electromagnetic compatibility), in conformity with EN 60495 standard and in conformity with ISO 11547 standard concerning requirements to prevent an outboard motor from being started in gear.

## ABYC AND NMMA CERTIFICATIONS



## GOOD RETURN POLICY

Any product that is presumed defective should be reported to Uflex USA within 48 hours of receipt or discovery in the field. Upon notification Uflex USA will attempt to troubleshoot the problem with our customer over the phone. If we are unable to resolve the problem Uflex will issue a Return Goods Authorization number and we require that the product in question be returned to Uflex with all of its parts in its original packaging. The product should be returned freight prepaid to:

**Uflex USA**  
**RGA Department – RGA #**  
**6442 Parkland Drive**  
**Sarasota, Florida 34243**  
**sales@uflexusa.com**

Upon receipt Uflex will examine the product to determine the cause of the defect. If the product is determined to have a defect in workmanship or material, it will be repaired or replaced at our discretion.

Our warranty does not cover labor, towing or other expenses. Further, it does not cover products that have been improperly installed, damaged in installation, misapplied, or misused.

Our products are not intended for use in racing applications.

*The descriptions and guidelines shown in this catalog should be used as general reference only. For any further information please contact our Technical Service.*

## PROP 65

Some of the products offered by Uflex may include chemicals which are subject to Prop 65 Warning. These products will have the following warning labels. For more information contact Uflex USA directly at 941.351.2628.

 **WARNING:** Cancer -[www.P65Warnings.ca.gov/product](http://www.P65Warnings.ca.gov/product)

 **WARNING:** Reproductive Harm -[www.P65Warnings.ca.gov/product](http://www.P65Warnings.ca.gov/product)

 **WARNING:** Cancer and Reproductive Harm -[www.P65Warnings.ca.gov/product](http://www.P65Warnings.ca.gov/product)



# SELECTING A MECHANICAL STEERING SYSTEM

## Steering Torque

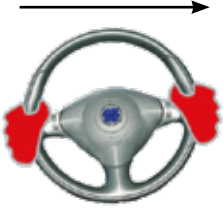

Choosing the appropriate system for your application can sometimes be confusing because of the variety of steering systems available. There are 4 basic steering types: Mechanical Rotary, Mechanical Rack, Hydraulic and Power Steering that cover most of the styles of recreational powerboats. The Mechanical Rotary, Mechanical Rack and Pinion are available in standard or Zerotorque Feedback versions.

Selecting among these options is dependent upon the speed and handling characteristics of your particular boat. If your boat is an outboard or if it has a sterndrive without power steering, you need to consider steering systems that reduce the rudder torque feedback that you feel while driving your boat.

Feedback is the constant effort you have to put on the steering wheel just to go straight, and it is why it takes more effort to steer one direction than the other.

The amount of feedback depends on the boat, the propeller and the steering system in the boat. Generally speaking, the faster you are going the more amount of effort you have to put on the steering wheel to keep the boat going straight.

## Planetary Gear Design

Uflex offers rotary systems featuring a “Planetary Gear Design” with 3 satellite gears which distributes steering feedback more evenly and effectively throughout the helm.

The result is a reduction in the amount of effort needed to steer the boat straight or into the direction of the steering torque.

Uflex Planetary Gear Design also spreads the wear of the steering direction changes over a wider wear area which reduces overall wear and the correspondent lost motion.



## Single Contact Point



## ROTECH™

The competitively priced complete system from Uflex is called the Rotech.

The Planetary Gear Design of the Rotech and FourTech contrasts conventional systems which have only one contact point between two drive gears. The single contact point of conventional systems receives all the torque from the engine, which can eventually lead to uneven gear wear and correspondent lost motion in the steering.

The Rotech and FourTech include helm, bezel and cable. They are a direct replacement for competing rotary systems requiring no new holes in the dash.

## ACCURA™

For outboard boats, sterndrives without power assist or other applications with moderate torque loads it is recommended to upgrade to system with a clutch or gears which automatically lock out the steering torque while the system is not actively being turned.

Uflex offers the Accura and FourTech-ZTF systems with the same Planetary Gear Design but in a ZeroTorque configuration, which does not require a constant effort on the steering wheel to keep the boat going straight or in the intended direction.

A special spring clutch holds the steering system on its intended course until the next change in the direction is initiated by the driver.

## FOURTECH™

Specifically designed for high performance and high efficiency applications, the Fourtech offers performance, flexibility and durability increased by top quality materials and construction.

The Fourtech package includes T91 helm (PLANETARY GEAR DESIGN), bezel and highly flexible M90 Mach cable.

The Fourtech-ZTF package includes T93ZT (zero torque configuration) helm, bezel and M90 Mach cable and presents the same technical features as Fourtech.

## RACKTECH™

Rack and Pinion steering systems are generally found on boats where space between the drivers knees and the steering helm is limited. Racks are particularly common in the ski boat market where the freeboard of the boats tend to be smaller.

Rack and Pinion systems have the similar design issues as conventional rotary helms. Accordingly, all the steering loads are transmitted to one contact point and there is uneven wear in the system.

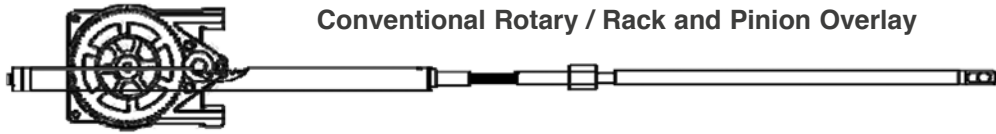

## ACCUTECH™

For boats that do have space constraints, Uflex offers the Racktech steering package that consists of a helm, bezel and steering cable. The ZeroTorque version of the Uflex rack and pinion is the Accutech, which features a spring clutch to allow for smooth transition in and out of the ZeroTorque mode.

Both systems come with the TM87 Rack Cable which has an armor wrapped stranded wire core for high efficiency and smooth steering.

If you have a boat that has the space, it is recommended to take advantage of the Planetary Gear Designed rotary helms to reduce feedback and to improve longevity of the helm.

## EFFICIENCY COMPARISON TESTS

### Push load:

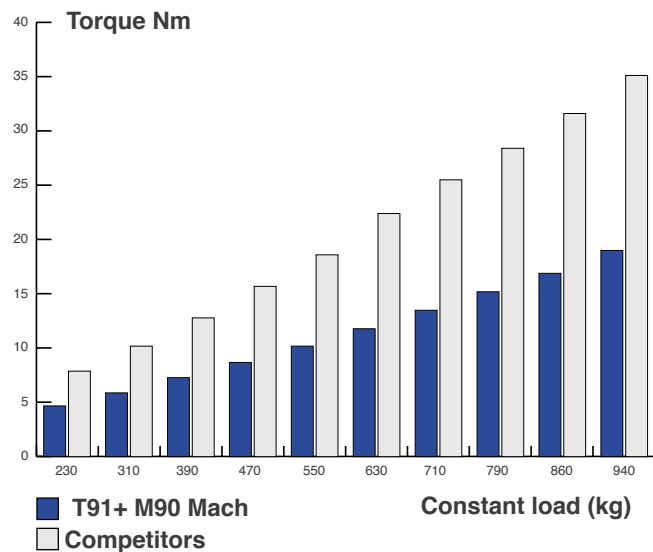

### Pull load:

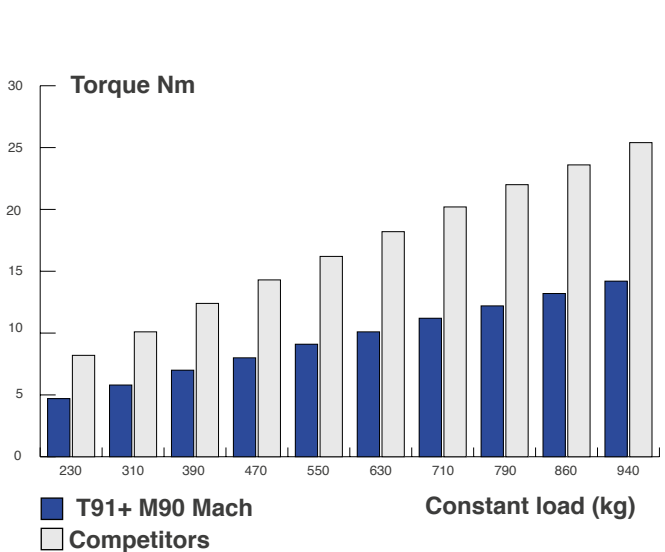

## USE AND MAINTENANCE

The steering cable must be installed avoiding excessive and/or tight bends. This will provide the driver with easy handling at all speeds, helping to reduce system inefficiency, and excess play in the system.

Marine corrosion may cause the materials to deteriorate affecting maneuvering efficiency and in the worst case, system failure. By following the engine manufacturer specifications, the steering cable end fittings and the engine cable support must be cleaned and greased periodically; these simple operations minimize wear and corrosion in the system.

The steering cable must be regularly inspected. If steering becomes hard, inconsistent, cuts on the conduit surface are noticed, or any other component found damaged, the cable must be replaced immediately.

When storing your boat for an extended period of time we recommend removing the steering cable end fitting from its engine side support and cleaning it adequately.

## HYDRAULIC STEERING SYSTEMS

Hydraulics are more and more popular on mid to high horsepower outboard applications. The increased application of hydraulics has a lot to do with the increase in horsepower over the years, and the added torque that is inherent with 4 stroke outboards compared to 2 strokes. The high output torque of the 4 strokes has changed the propellers resulting in higher torque loads on the steering systems. Hydraulic systems are very efficient in dealing with all torque conditions and often provide for fingertip steering effort.

Uflex offers a simple application guide to assist in selecting the appropriate model cylinder according to the make and model of your engine at [www.uflexusa.com](http://www.uflexusa.com). The Uflex helms are compatible with competing helms, hoses, cylinders and oil, so you can easily install a Uflex component regardless of what item you need to replace.



Outboard systems are generally broken down into three systems; one for applications below 115 hp, one for applications below 150 hp and different systems for above 150 hp.

### GOTECH™

The most affordable hydraulic steering option in the market, the GoTech™, is the perfect solution for low horsepower up to 115 hp, high torque four stroke outboards. Featuring a mid-mount composite helm and anodized aluminum front mount cylinder the GoTech™ offers smooth and easy steering with 4.5 turns lock to lock. It is an ideal system for pontoon boats, rigid hulled inflatables, walleye boats and any other application where mechanical steering is not adequate for steering loads of today's outboards.

### HYCO™

Uflex offers the Hyco package which has a clever mounting system that allows you to install a front mount outboard cylinder without having to remove the engine. With the split tilt tube design of the Uflex Hyco, you can simply cut the old mechanical steering cable, insert the two tilt tube pieces independently and pin them to complete the hydraulic cylinder installation. The cylinder is suspended in front of the engine and oil directed from the hydraulic helm moves the engine correspondent to the direction of the steering wheel. Suitable up to 150 hp installations.

### HYTECH™

Uflex offers the Hytech package which has a clever mounting system that allows you to install a front mount outboard cylinder without having to remove the engine. With the split tilt tube design of the Uflex Hytech, you can simply cut the old mechanical steering cable, insert the two tilt tube pieces independently and pin them to complete the hydraulic cylinder installation. The cylinder is suspended in front of the engine and oil directed from the hydraulic helm moves the engine correspondent to the direction of the steering wheel. Suitable up to 175 hp installations.

### PROTECH™

Larger horsepower applications require a more robust steering cylinder. The Uflex Protech cylinder is designed for single, dual and triple engine applications (Please, contact our Technical Department for 3 engine installations). Featuring heavy duty seals, 304 electropolished link assemblies, and a carbon steel piston, it is built for the most demanding applications.

### SILVERSTEER™ & MASTERDRIVE™

For especially high torque applications you may want to consider using a 1500 psi helm, which has relief valves set 500 Psi higher than the standard hydraulic helms which are rated to 1000 Psi. Bass, flats and other high horsepower boats with jackplates and shallow V deadrise experience extreme torque where the helm needs to have higher relief settings.

Uflex offers the Silversteer and Masterdrive helm and cylinder for these applications. With the same benefits as the Protech cylinder, the Silversteer cylinder also features a keyed bullhorn design that maximizes the rigidity of the cylinder when dealing with peak torque loads.

Large inboard boats with displacement hulls can generate high torque loads. Uflex offers a wide variety of hydraulic helms and cylinders that can be paired together to provide optimal steering for your application







# SELECTION OF STEERING SYSTEM

## and cable length measurement

- Speed, hull, horsepower, engine type, displacement and size are major factors in boat performance and handling characteristics. The above selection guide should be used as a general reference only.
- One of the major factors in selecting a steering system is proper cable length.
 

Due to specific routing in each boat, these approximate lengths will vary. Final selection should be made with the assistance of a qualified technician.
- Uflex mechanical steering systems should not be used on boats equipped with engines that exceed the maximum horsepower rating of the boat.

APPLICATIONS	BOAT LENGTH	STEERING SYSTEM	
 OUTBOARD	up to 30' (9m)	T71FC - T81FC T73NRFC - T83NRFC T91 - T93ZT T101 - T103ZT TM87O - TM87OZT	Uflex hydraulic steering systems are recommended for boats that exceed 50 mph. Always follow engine manufacturer's instructions.
 INBOARD	up to 35' (10.5m)	T71FC - T81FC - T73NRFC - T83NRFC - TM87SS - T91 - T93ZT - T101 - T103ZT	
 STERNDRIVE POWER ASSISTED		T71FC - T81FC - TM87SS - T91 - T101	
 JET BOATS		TM87J	
		Twin cable rotary steering systems	

**NOTE:** sterndrive engines not equipped with power steering can create very high steering loads. Our hydraulic steering systems are recommended for these type of boats. For any further information please contact our Technical Service Department.

### How to measure for new steering cable installation

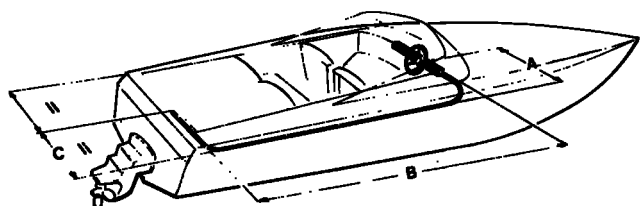

Add the lengths of A + B + C together and subtract 4" (10 cm) for each 90° bend.  
 Add 12" (30.5 cm) for the engine tilt tube.  
 To order in foot length, round up to the nearest whole foot.

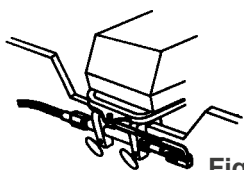

Fig. 1

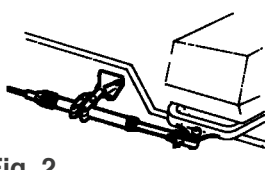

Fig. 2

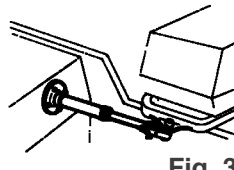

Fig. 3

#### TILT TUBE MOUNTING - Fig. 1





Example: A (2.5') + B (10.5') + C (3') = 16'  
 16' - 8" (two 90° bends) = 15'4"  
 15'4" + 12" (tilt tube) = 16'4" Round up to 17'

#### TRANSOM SUPPORT OR SPLASHWELL MOUNTING - Fig. 2-3

Example:  
 A (2.5') + B (10.5') + C (3') = 16'  
 16' - 8" (two 90° bends) = 15'4" Round up to 16'

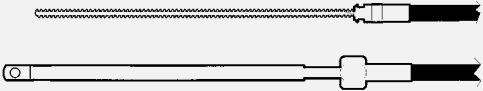

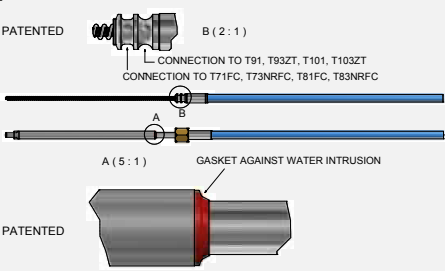
# REPLACEMENT STEERING CABLES

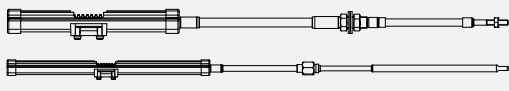
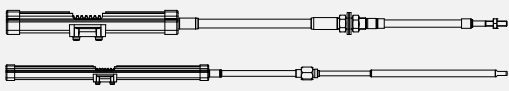
UFLEX REPLACEMENT STEERING CABLE	STEERING HELM	ADAPTOR REQUIRED
<p><b>M66</b></p> 	<p>Uflex T71FC - T72FC - T73NR FC - T81FC - T82FC - T83NR FC - Teleflex® Safe - TQC®/NFB® - Morse® D290</p> <p>Uflex year 2001 and prior: T71 - T72 - T73NR T81 - T82 T83NR - T84NR</p>	<p>none</p> <p><b>K66 - 38432Q</b></p> 
<p><b>M68 + M67</b></p> 	<p><b>Dual station steering systems:</b> Uflex T71FC</p>	<p>none</p>
<p><b>M90 Mach</b></p> 	<p>T91 - T93ZT T101 - T103ZT T71FC - T72FC - T73NRFC T81FC - T82FC - T83NRFC Ultraflex Safe - TQC® - NFB Safe TII® NFB 4.2® Teleflex® - D290 Morse®</p>	<p>none</p>
<p><b>TM86 - DISCONTINUED</b></p> 	<p>Uflex G86 - G88NR G96 - G98NR. Not compatible with TM87J and TM87SS Morse® Command 200 Teleflex® "THE RACK" SSC-124 Not compatible TM87O</p> <p><b>NOTE: Will not work with dual cable helms</b></p>	<p>none</p>
<p><b>TM87O</b></p> 	<p>G87 - G87ZT - G89 - G89ZT Ultraflex. (Not compatible with TM86)</p> <p>TM87O compatible with Teleflex® SSC134, SSCX154</p>	<p>none</p>
<p><b>TM87J - TM87SS</b></p> 	<p>G87 - G87ZT - G89 - G89ZT Uflex. Not compatible with TM86 TM87SS compatible with Teleflex® SSC134, SSCX154 TM87J compatible with Teleflex® SSC145, SSC146</p>	<p>none</p>

## How to measure for replacement steering cables

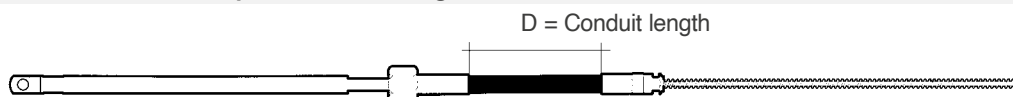

**ORDER LENGTH:** "D" dimension + 22" and round up to the next whole foot

Example:  $D = 120" + 22" = 142"$  (11'8"). Round up to 12 ft

# T71FC - T72FC Rotary steering systems

CE UK  
CA

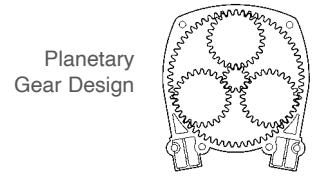

T71FC



T72FC

- Fast connect, simple installation
- All stainless steel cable output ends
- Made of corrosion resistant materials
- Standard 3/4" tapered shaft
- Minimal feedback
- T71FC and T72FC steering systems are not to be used on boats equipped with engines that exceed the maximum horsepower rating of the boat
- For boats faster than 50 mph our hydraulic steering systems are recommended
- T71 is available in package including X34 bezel and M66 cable with ROTECH
- Exceeds ISO 8848 safety standards
- Exceeds ABYC P17 safety standards

**NOTE**

T72FC steering system requires 2 cables

**COMPONENTS - TO BE ORDERED SEPARATELY**

Model	Part No.	Description
T71FC	38867H	Single cable steering Helm
T72FC	38868K	Dual cable steering Helm
X34	36654B	Black bezel, 90° mounting
X34W	40654C	White bezel, 90° mounting
X91	42850N	Chrome plated bezel, 90° mounting
X35	36655C	Black bezel, 20° mounting
M66 or M90	-	Steering cable
Steering wheel	-	See steering wheels section
Accessories	-	See accessories section

Installation	90° or 20°
M66 - M90 steering cable stroke	9" (228 mm)
Lock-to-lock steering wheel turns	approx 3.8
Max. steering wheel diameter	16" (406 mm)
Min. steering cable bend radius	7.9" (200 mm)

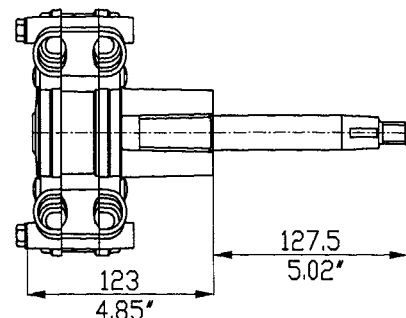
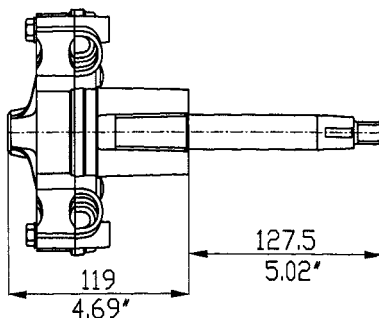
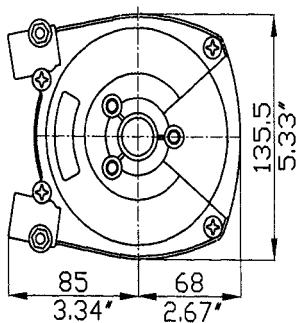

# T73NRFC

## Zero torque rotary steering systems

CE UK  
CA



Planetary  
Gear Design

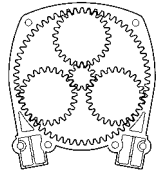

T73NRFC

- Easy and safe steering : a patented non-reversible mechanism eliminates the continuous load on the operator caused by the propeller torque
- Fast connect, simple installation
- Compact rotary helm unit: the central location of the steering shaft makes these systems the most compact in their class
- Most suitable where clearance is limited
- Ideal for outboards and surfacing propellers
- Standard 3/4" tapered shaft
- All stainless steel cable output ends
- Made of corrosion resistant materials
- T73NRFC steering system is not to be used on boats equipped with engines that exceed the maximum horsepower rating of the boat
- Available in package including the X34 bezel and M66 cable with ACCURA
- Exceeds ISO 8848 safety standards
- Exceeds ABYC P17 safety standards

### COMPONENTS - TO BE ORDERED SEPARATELY

Model	Part No.	Description
T73FC	38869M	Zero torque single cable steering helm
X34	36654B	Black bezel, 90° mounting
X34W	40654C	White bezel, 90° mounting
X91	42850N	Chrome plated bezel, 90° mounting
X35	36655C	Black bezel, 20° mounting
M66 or M90	-	Steering cable
Steering wheel	-	See steering wheels section
Accessories	-	See accessories section

Installation	90° or 20°
M66 - M90 steering cable stroke	9" (228 mm)
Lock-to-lock steering wheel turns	approx 3.8
Max. steering wheel diameter	16" (406 mm)
Min. steering cable bend radius	7.9" (200 mm)

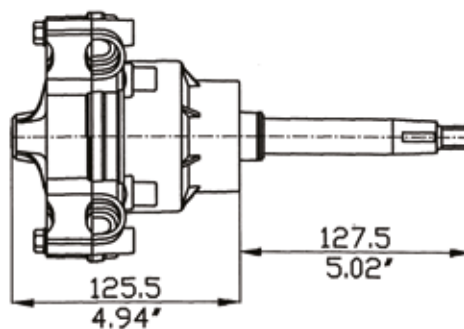
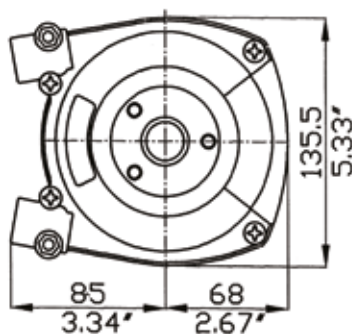

# T81FC - T83NRFC (zero torque) ROTARY TILT STEERING SYSTEM



Planetary  
Gear Design

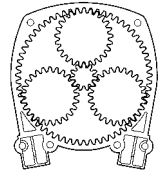

T81FC with X82



X82

- Tilt range of 48° and five locking positions
- Fast connect, simple installation
- Tilt device eliminates underdash movement
- Standard 3/4" tapered shaft – stainless steel
- All stainless steel cable output ends
- Made of corrosion resistant materials
- T81FC and T83NRFC steering systems are not to be used on boats equipped with engines that exceed the maximum horsepower rating of the boat
- X82 tilt mechanism fits Uflex tilt mount rotary and rack and pinion steering helms as well as Uflex tilt mount hydraulic pumps except SilverSteer™ and MasterDrive™ steering systems
- For boats faster than 50 mph our hydraulic steering systems are recommended
- Exceeds ISO 8848 safety standards
- Exceeds ABYC P17 safety standards

## COMPONENTS - TO BE ORDERED SEPARATELY

Model	Part No.	Description
T81FC	38957J	Single cable steering helm
T83NRFC	38959N	Zero torque single cable steering Helm
X82	43187N	Tilt mechanism
M66 or M90	-	Steering cable
Steering wheel	-	See steering wheels section
Accessories	-	See accessories section

Installation	with Tilt X82
M66-M90 Mach steering cable stroke	228 mm (9")
Lock-to-lock steering wheel turns	approx 3.8
Max. dash depth	1" (25,4 mm)
Max. steering wheel diameter	16" (406 mm)
Min. steering cable bend radius	7.9" (200 mm)

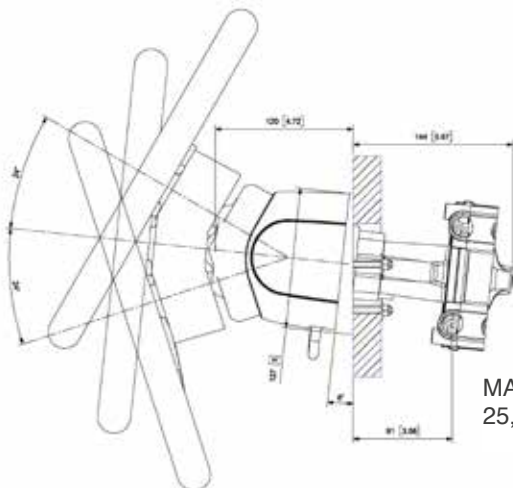

MAX DASH DEPTH  
25,4 mm (1")

# T91 High Performance rotary steering system



T91 high performance



T91 with X91 bezel

Planetary Gear Design

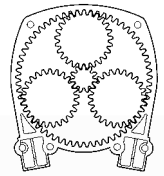

M90 Mach (Patented)

- Specifically designed for high performance and high efficiency applications
- M90 Mach cable (patented): performance, flexibility and durability increased by top quality materials and construction.
- Fast connect, simple installation, patented end fitting.
- Stainless steel cable output end featuring patented gasket, engine side
- Made of corrosion resistant materials
- Particularly suitable when clearance is limited.
- Standard 3/4" tapered shaft
- Minimal feedback
- T91 steering system is not to be used on boats equipped with engines that exceed the maximum horsepower rating of the boat
- For boats faster than 50 mph our hydraulic steering systems are recommended
- T91 is also available in package with FOURTECH
- Exceeds ISO 8848 safety standards
- Exceeds ABYC P17 safety standards

## COMPONENTS - TO BE ORDERED SEPARATELY

Model	Part No.	Description
T91	42647S	Single cable steering helm
X34	36654B	Black bezel, 90° mounting
X34W	40654C	White bezel, 90° mounting
X91	42850N	Chrome plated bezel, 90° mounting
X90	42646P	Chrome plated bezel, 90° mounting with lock device
X35	36655C	Black bezel, 20° mounting
M90 Mach	-	Steering cable
Steering wheel	-	See steering wheels section
Accessories	-	See accessories section
Installation		90° or 20°
M90 Mach steering cable stroke		9" (228 mm)
Lock-to-lock steering wheel turns		approx 4.2
Max. steering wheel diameter		16" (406 mm)
Suggested steering cable bend radius		7.87" (200 mm)
Min. steering cable bend radius		5.9" (150 mm)

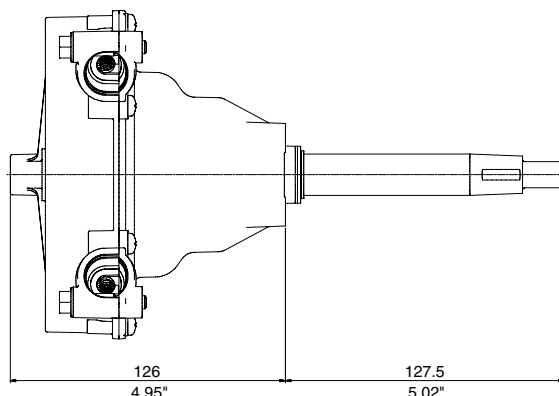
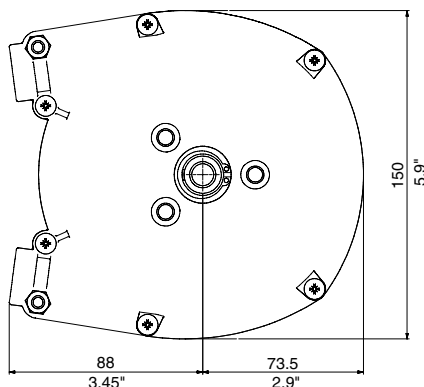



# T93ZT (zero torque) High performance rotary steering systems



T93ZT high performance



T93ZT with X91 bezel

Planetary  
Gear Design

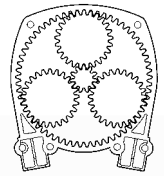

M90 Mach  
(Patented)

- Specifically designed for high performance and high efficiency applications
- M90 Mach cable (patented): performance, flexibility and durability increased by top quality materials and construction.
- Fast connect, simple installation, patented end fitting.
- Stainless steel cable output end featuring patented gasket, engine side
- Made of corrosion resistant materials
- Particularly suitable when clearance is limited.
- Standard 3/4" tapered shaft
- Minimal feedback
- T93ZT steering system is not to be used on boats equipped with engines that exceed the maximum horsepower rating of the boat
- For boats faster than 50 mph our hydraulic steering systems are recommended
- T93ZT is also available in package with FOURTECH-ZTF
- Exceeds ISO 8848 safety standards
- Exceeds ABYC P17 safety standards

## COMPONENTS - TO BE ORDERED SEPARATELY

Model	Part No.	Description
T93ZT	42648U	Zero torque single cable steering helm
X34	36654B	Black bezel, 90° mounting
X34W	40654C	White bezel, 90° mounting
X91	42850N	Chrome plated bezel, 90° mounting
X90	42646P	Chrome plated bezel, 90° mounting with lock device
X35	36655C	Black bezel, 20° mounting
M90 Mach	-	Steering cable
Steering wheel	-	See steering wheels section
Accessories	-	See accessories section
Installation		90° or 20°
M90 Mach steering cable stroke		9" (228 mm)
Lock-to-lock steering wheel turns		approx 4.2
Max. steering wheel diameter		16" (406 mm)
Suggested steering cable bend radius		7.87" (200 mm)
Min. steering cable bend radius		5.9" (150 mm)

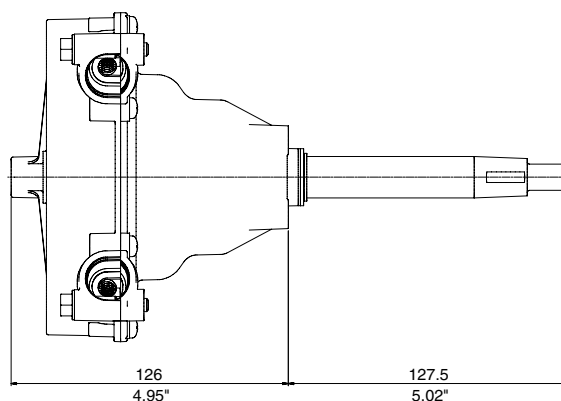
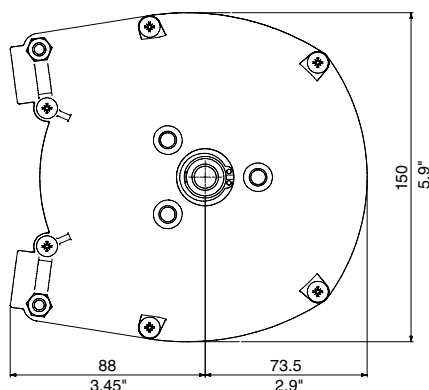

# T101 - T103ZT (zero torque) High performance tilt steering systems

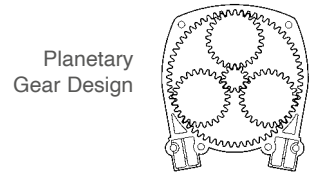

T101 high performance



T101 shown with X82 tilt mechanism



T103ZT high performance

- Specifically designed for high performance and high efficiency applications
- M90 Mach cable (patented): performance, flexibility and durability increased by top quality materials and construction.
- Tilt range of 48° and five locking positions
- Fast connect, simple installation, patented end fitting.
- Tilt device eliminates underdash movement
- Standard 3/4" tapered shaft – stainless steel
- Engine side stainless steel cable output end featuring patented gasket
- Made of corrosion resistant materials
- T101 and T103ZT steering system is not to be used on boats equipped with engines that exceed the maximum horsepower rating of the boat
- For boats faster than 50 mph our hydraulic steering systems are recommended
- Exceeds ISO 8848 safety standards
- Exceeds ABYC P17 safety standards

## COMPONENTS - TO BE ORDERED SEPARATELY

Model	Part No.	Description
T101	42839B	Single cable steering helm
T103ZT	42840K	Zero torque single cable steering helm
X82	43187N	Tilt mechanism
M90 Mach	-	Steering cable
Steering wheel	-	See steering wheels section
Accessories	-	See accessories section

Installation	With Tilt X52
M90 steering cable stroke	9" (228 mm)
Lock-to-lock steering wheel turns	approx 3.8
Max. steering wheel diameter	16" (406 mm)
Tilt mechanism X82	Not included - to be ordered separately
Suggested steering cable bend radius	7.87" (200 mm)
Min. steering cable bend radius	5.9" (150 mm)

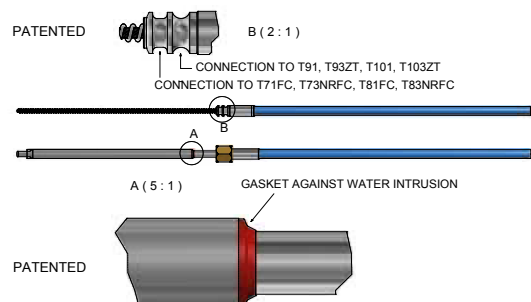
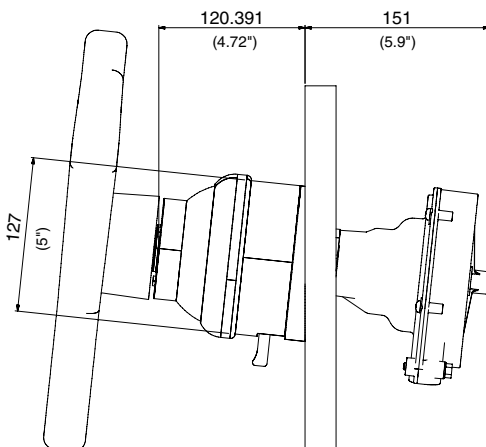

# M90 HIGH EFFICIENCY AND FLEXIBILITY STEERING CABLE

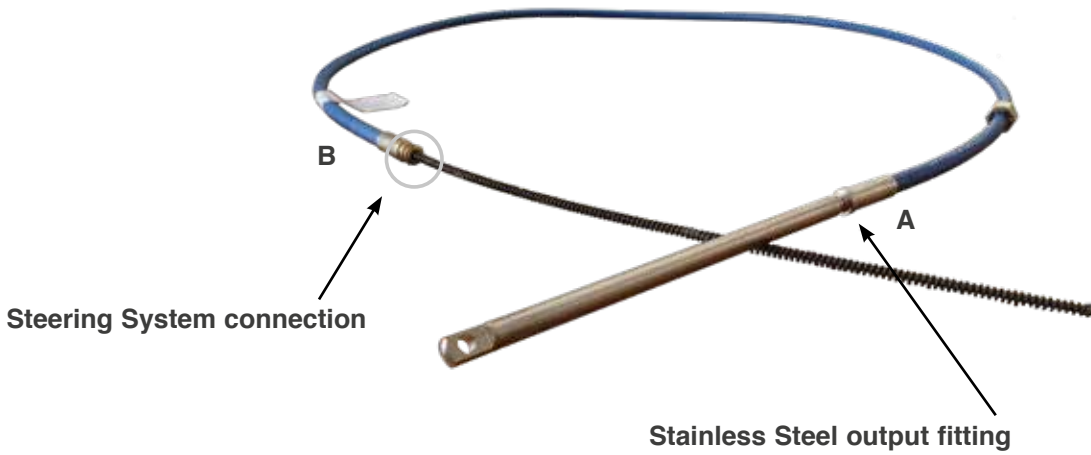

PATENTED

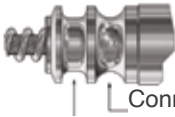

Connection to:  
T91, T93ZT, T101, T103ZT

Connection to:  
T71FC, T73NRFC,  
T81FC, T83NRFC

GASKET AGAINST WATER INTRUSION



Specifically designed for high performance and high efficiency applications, M90 Mach cable (patented) offers increased flexibility and durability by top quality materials and construction.

- Ideal solution for long cable runs and tight bend applications
- Corrosion resistant materials, stainless steel engine side output fitting
- Minimal feedback
- Fast connect, simple installation, patented end fitting
- Stainless steel cable output end featuring **patented gasket**, engine side

<b>Min. steering cable bend radius</b>	5.9" (150 mm)
<b>Suitable for use with</b>	T91, T93ZT, T101, T103ZT, T71FC, T72FC, T73NRFC, T81FC, T82FC, T83NRFC.

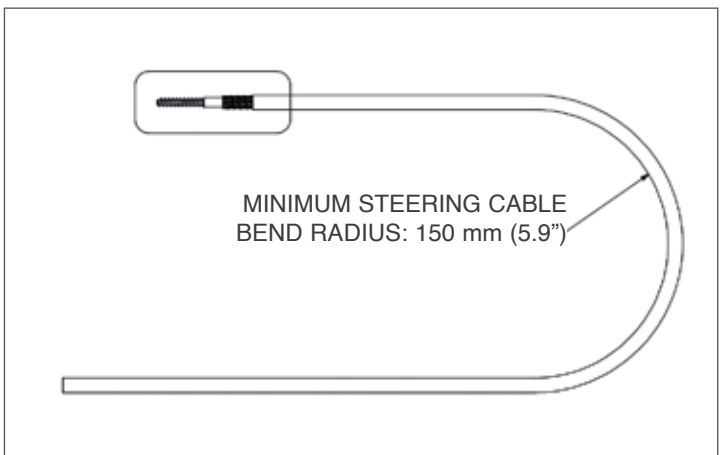
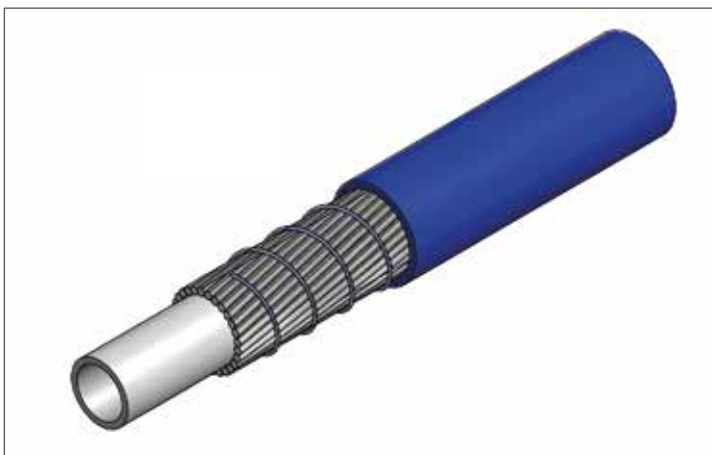

# T91 -T93ZT (zero torque) High Performance steering systems - Torque Comparison

## Backlash on the steering system comparison

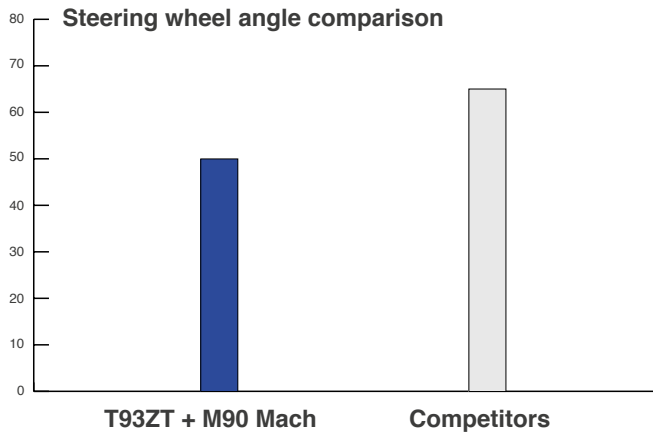

The quality of a mechanical steering system depends on its efficiency (less driving effort) in push & pull load and low backlash on the steering wheel.

Uflex **T91** and **T93ZT** steering systems, fitted with the **M90 Mach** single-cable, are the best mechanical steering systems on the market today. They combine a minimal backlash with higher efficiency and they guarantee results with very narrow cable bends.

## Torque comparison with Push & Pull load - radius 200m

### Push load:

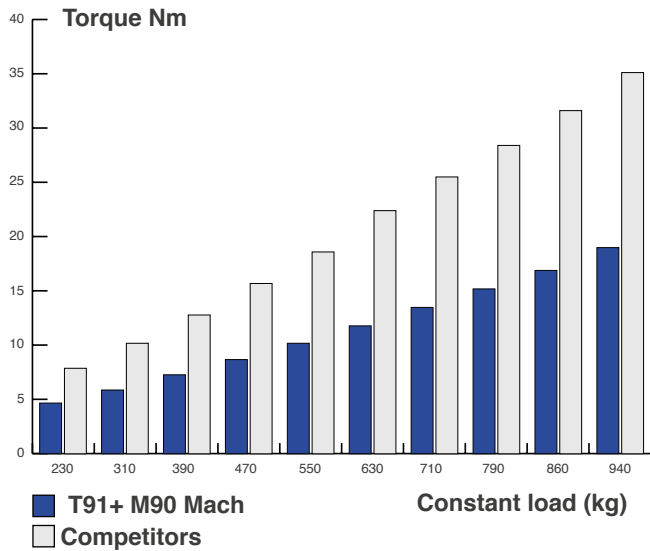

### Pull load:

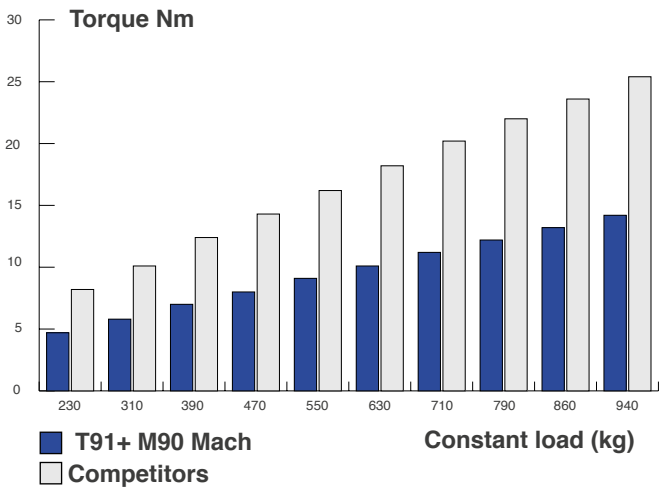

## Torque comparison with Push & Pull load - radius 100m

### Push load:

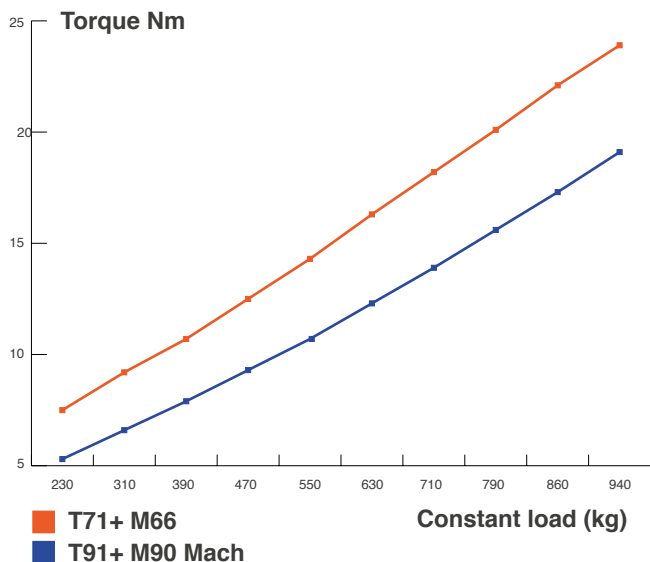

### Pull load:

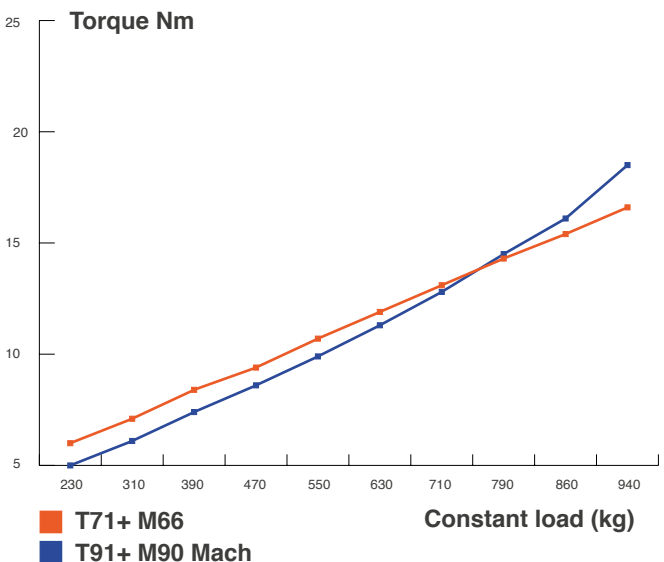

# TM870 - TM870ZT (zero torque) Rack and pinion steering systems

**new**

CE UK  
UK RA



G87



G87ZT



- All stainless steel cable output ends
- Made of corrosion resistant materials
- Standard 3/4" tapered shaft
- The ZT version, equipped with a zero torque patented mechanism, eliminates the continuous load on the driver caused by the propeller torque
- TM870 steering systems are not to be used on boats equipped with engines that exceed the maximum horsepower rating of the boat
- Optional steering wheel
- Exceeds ISO 8848 safety standards
- Exceeds ABYC P17 safety standards

## COMPONENTS - TO BE ORDERED SEPARATELY

Model	Part No.	Description
TM870	-	Preassembled helm with steering cable
G87	43838E	Standard shaft assembly
G87ZT	43837C	Zero torque shaft assembly
X34	36654B	Black bezel, 90° mounting
X34W	40654C	White bezel, 90° mounting
X91	42850N	Chrome plated bezel, 90° mounting
X90	42646P	Chrome plated bezel, 90° mounting with lock device
X35	36655C	Black bezel, 20° mounting
Steering wheel	-	See steering wheels section
Accessories	-	See accessories section

Installation	90° or 20°
TM870 stroke	200 mm (3.7")
Lock-to-lock steering wheel turns	approx 3,3
Max. steering wheel diameter	420 mm (16.5")
Min. steering cable bend radius	200 mm (7.9")

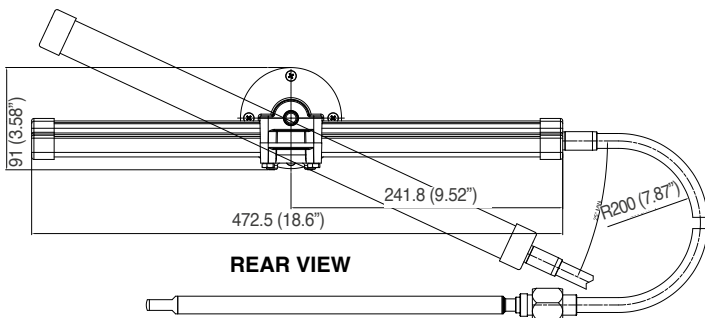

TM870

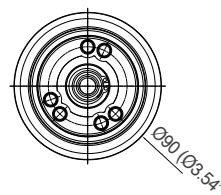

G87 and G87ZT

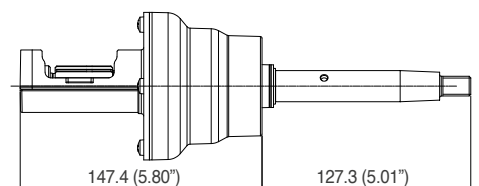

# TM870 - TM870ZT (zero torque) Rack and pinion tilt steering systems



**new**



## COMPONENTS - TO BE ORDERED SEPARATELY

Model	Part No.	Description
TM870	-	Preassembled helm with steering cable
G89	43844Z	Standard helm suitable for X82 tilt mechanism
G89ZT	43845B	Zero torque helm suitable for X82 tilt mechanism
X82	43187N	Tilt mechanism
Steering wheel	-	See steering wheels section
Accessories	-	See accessories section

- All stainless steel cable output ends
- Made of corrosion resistant materials
- Standard 3/4" tapered shaft
- The ZT version, equipped with a zero torque patented mechanism, eliminates the continuous load on the driver caused by the propeller torque
- TM870 steering systems are not to be used on boats equipped with engines that exceed the maximum horsepower rating of the boat
- Optional steering wheel
- Exceeds ISO 8848 safety standards
- Exceeds ABYC P17 safety standards

Installation	90° or 20°
TM870 stroke	200 mm (3.7")
Lock-to-lock steering wheel turns	approx 3,3
Max. steering wheel diameter	420 mm (16.5")
Min. steering cable bend radius	200 mm (7.9")

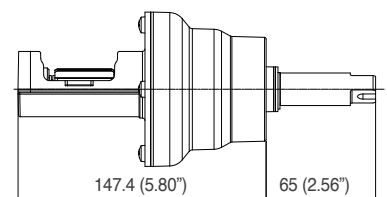
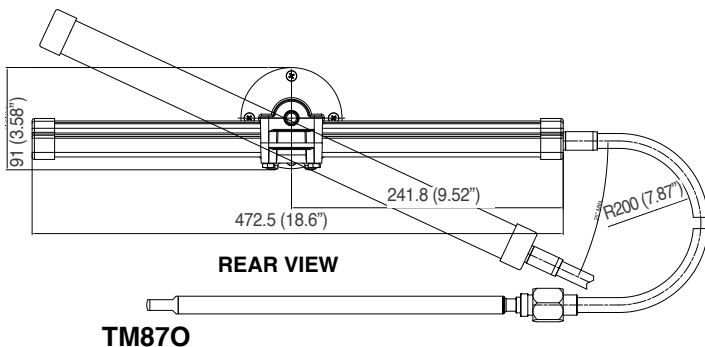



# TM87SS - TM87SSZT (zero torque) Rack and pinion steering systems for ski boats



G87



G87ZT



- Armoured stainless steel cable, armoured conduit
- Made of corrosion resistant materials
- Standard 3/4" tapered shaft
- The ZT version equipped with a zero torque patented mechanism, eliminates the continuous load on the drivers caused by the propeller torque
- TM87SS steering systems are not to be used on boats equipped with engines that exceed the maximum horsepower rating of the boat
- Optional steering wheel
- Exceeds ISO 8848 safety standards
- Exceeds ABYC P17 safety standards

## COMPONENTS - TO BE ORDERED SEPARATELY

Model	Part No.	Description
TM87SS	-	Preassembled helm with steering cable
G87	43838E	Standard helm
G87ZT	43837C	Zero torque helm
X34	36654B	Black bezel, 90° mounting
X34W	40654C	White bezel, 90° mounting
X91	42850N	Chrome plated bezel, 90° mounting
X90	42646P	Chrome plated bezel, 90° mounting with lock device
X35	36655C	Black bezel, 20° mounting
Steering wheel	-	See steering wheels section
Accessories	-	See accessories section

Installation	90° or 20°
TM87SS stroke	200 mm (3.7")
Lock-to-lock steering wheel turns	approx 3,3
Max. steering wheel diameter	420 mm (16.5")
Min. steering cable bend radius	200 mm (7.9")

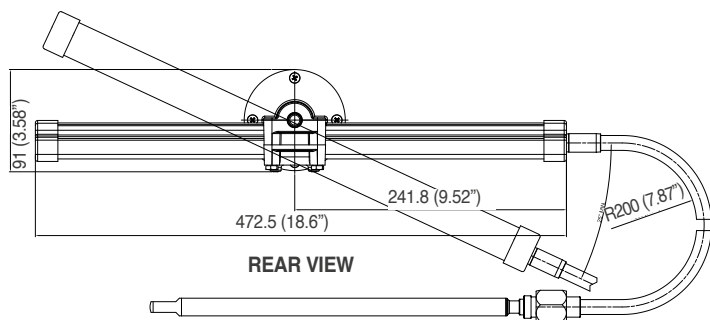

TM87SS

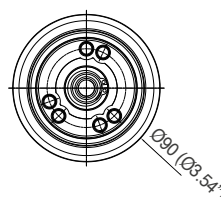

G87 and G87ZT

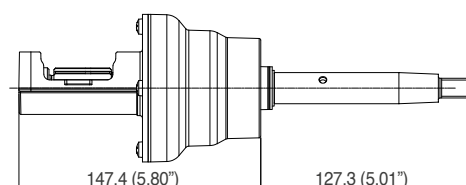

# TM87SS - TM87SSZT (zero torque) Rack and pinion tilt steering systems for ski boats



- Armoured stainless steel cable, armoured conduit
- Made of corrosion resistant materials
- Standard 3/4" tapered shaft
- The ZT version equipped with a zero torque patented mechanism, eliminates the continuous load on the drivers caused by the propeller torque
- TM87SS steering systems are not to be used on boats equipped with engines that exceed the maximum horsepower rating of the boat
- Optional steering wheel
- Exceeds ISO 8848 safety standards
- Exceeds ABYC P17 safety standards

## COMPONENTS - TO BE ORDERED SEPARATELY

Model	Part No.	Description
TM87SS	-	Preassembled helm with steering cable
G89	43844Z	Standard helm suitable for X82 tilt mechanism
G89ZT	43845B	Zero torque helm suitable for X82 tilt mechanism
X82	43187N	Tilt mechanism
Steering wheel	-	See steering wheels section
Accessories	-	See accessories section

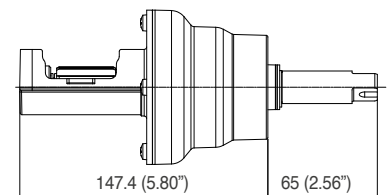
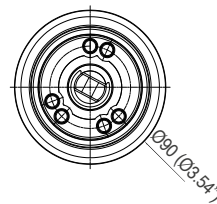
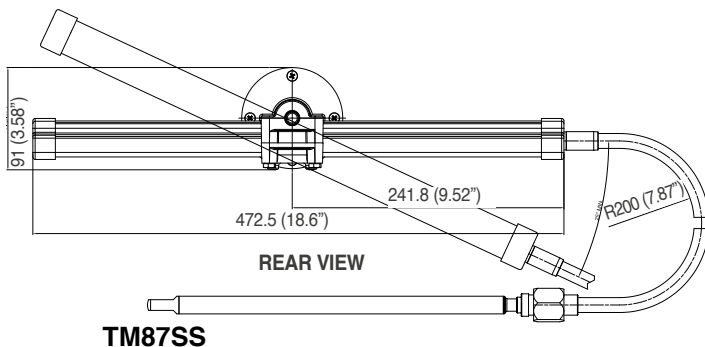

<b>Installation</b>	90° or 20°
<b>TM87SS stroke</b>	200 mm (3.7")
<b>Lock-to-lock steering wheel turns</b>	approx 3,3
<b>Max. steering wheel diameter</b>	420 mm (16.5")
<b>Min. steering cable bend radius</b>	200 mm (7.9")

# TM87J

## Rack and pinion steering systems for jet boats



- Armoured stainless steel cable
- Made of corrosion resistant materials
- Standard 3/4" tapered shaft
- TM87J steering systems are not to be used on boats equipped with engines that exceed the maximum horsepower rating of the boat
- Optional steering wheel
- Exceeds ISO 8848 safety standards
- Exceeds ABYC P17 safety standards

### COMPONENTS - TO BE ORDERED SEPARATELY

Model	Part No.	Description
TM87J	-	Preassembled helm with steering cable
G87	43838E	Standard helm
X34	36654B	Black bezel, 90° mounting
X34W	40654C	White bezel, 90° mounting
X91	42850N	Chrome plated bezel, 90° mounting
X90	42646P	Chrome plated bezel, 90° mounting with lock device
X35	36655C	Black bezel, 20° mounting
Steering wheel	-	See steering wheels section
Accessories	-	See accessories section

Installation	90° or 20°
TM87J stroke	93 mm (3.7")
Lock-to-lock steering wheel turns	approx 1,5
Max. steering wheel diameter	420 mm (16.5")
Min. steering cable bend radius	200 mm (7.9")

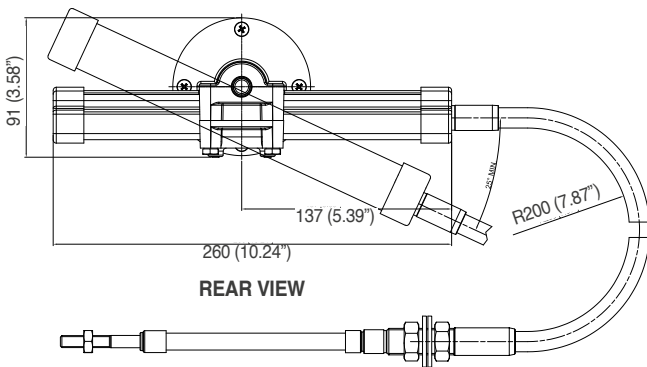

**TM87J**

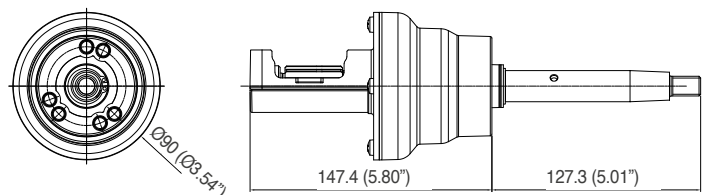



- Armoured stainless steel cable
- Made of corrosion resistant materials
- Standard 3/4" tapered shaft
- TM87J steering systems are not to be used on boats equipped with engines that exceed the maximum horsepower rating of the boat
- Optional steering wheel
- Exceeds ISO 8848 safety standards
- Exceeds ABYC P17 safety standards

### COMPONENTS - TO BE ORDERED SEPARATELY

Model	Part No.	Description
TM87J	-	Preassembled helm with steering cable
G89	43844Z	Standard helm suitable for X82 tilt mechanism
X82	43187N	Tilt mechanism
Steering wheel	-	See steering wheels section
Accessories	-	See accessories section

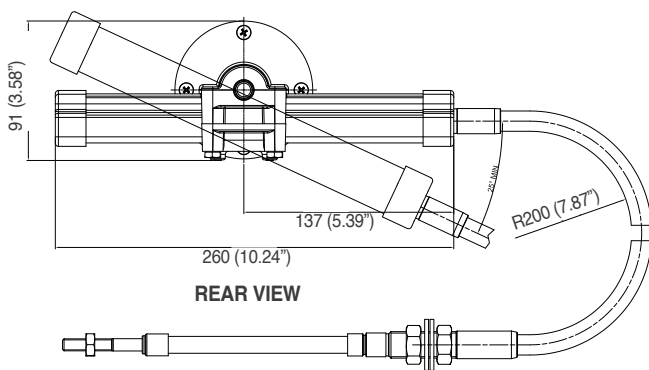

**TM87J**

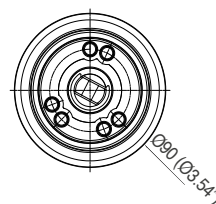

**G89**

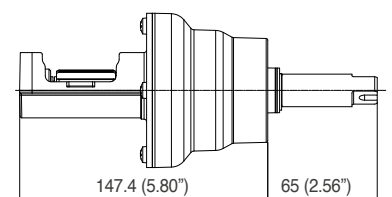

<b>Installation</b>	90° or 20°
<b>TM87J stroke</b>	93 mm (3.7")
<b>Lock-to-lock steering wheel turns</b>	approx 1,5
<b>Max. steering wheel diameter</b>	420 mm (16.5")
<b>Min. steering cable bend radius</b>	200 mm (7.9")



Now you can get the same technology used to drive the most powerful and best handling cars for your boat.

Taking the latest technology from the automotive industry, Uflex has combined Electronic Power Steering (EPS) used in the most popular cars in the world with the latest mechanical steering helms and Mach 90 high efficiency steering cable to deliver unprecedented performance.

Perfectly silent, the system draws minimal power and furthermore is very easy to install.

The NaviTech™ also has Integrated System Monitoring (ISM) which detects certain operating conditions including the number of cycles and notifies the end user with a vibration signal in the steering wheel, if the cable needs to be changed. Never before has a steering system monitored it's own operating conditions and given the driver diagnostic feedback.

For specific applications Uflex can use programmable software to dial in the hand wheel effort and steering output to meet specific performance objectives of boat builders.

## LIMIT OF APPLICATION

**Outboard engines:** Up to 150 hp, maximum 50 mph, no jackplates

**Inboard engines:** Max. application 200 hp, requires test and validation

## A complete steering system consists of:

- Power assisted steering helm:  
**T91NAV** - 43207S - single cable steering helm
- Tilt mechanism:  
**X88** - 44006L - Tilt mechanism for NaviTech™ tilt mount helms.  
Tilt range of 48° and five locking positions
- Steering cable: **M90 Nav** (patented)  
**WARNING:** M90 Nav steering cable is suitable for use also with T71FC, T72FC, T73NRFC, T81FC, T82FC, T83NRFC, T91, T93ZT, T101, T103ZT. Uflex steering helms. M66 will not fit the following Uflex helms: T91, T93ZT, T101, T103ZT.
- Optional steering wheel (see index)



M90 Nav (Patented)

## FEATURES AND TECHNICAL SPECIFICATIONS:

- Automotive steering effort and response
- 100% Balanced steering - Port to Starboard / Starboard to Port
- Silent Operation
- Monitoring software with integrated cycle counter, for a correct cable replacement.  
By haptic feedback on the wheel, the system is able to signal anomalies, such as:
  - Excessive cable load
  - Stuck cable alarm
- Field tested for over 3 years
- 16 Nm of assist torque capability
- Able to tune on center and end of stroke torque effort
- Consistent steering assist through all vessel speed ranges
- Applied in leading automotive application since 2011. Nowadays automotive production is over 1 million units per year
- 10 - 15 Vdc
- 8 - 15 A nominal current during steering maneuvers
- Supplied with 10 ft electrical harness. It needs a 40 A fuse (to be ordered separately).
- Validation for Marine application is per CE, ABYC P17 and ISO 8848
- NMMA Type Acceptance Completed



## LIMIT OF APPLICATION

### Outboard engines:

Up to 150 hp, maximum 50 mph, no jackplates

### Inboard engines:

Max. application 200 hp, requires test and validation

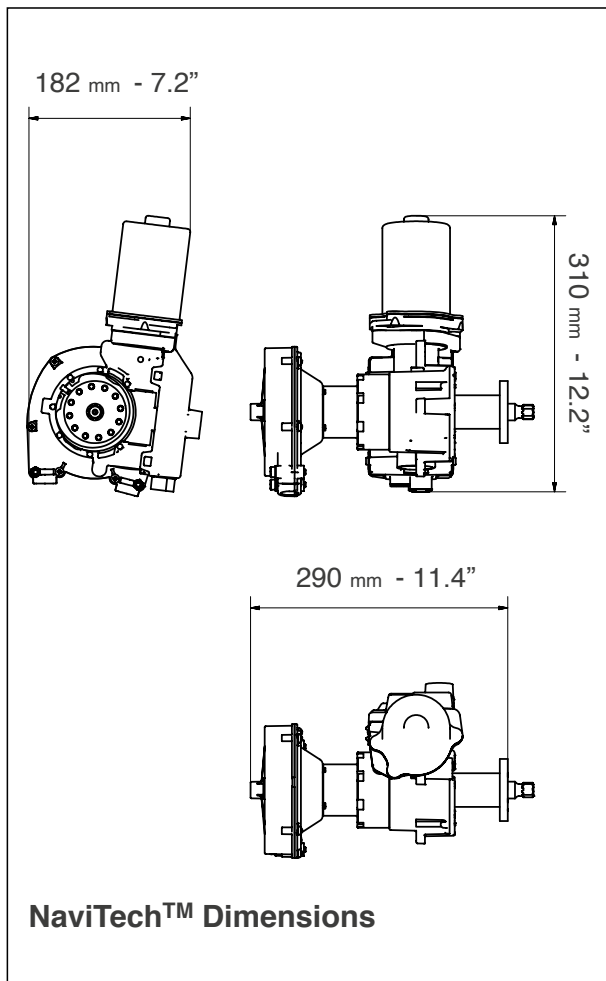
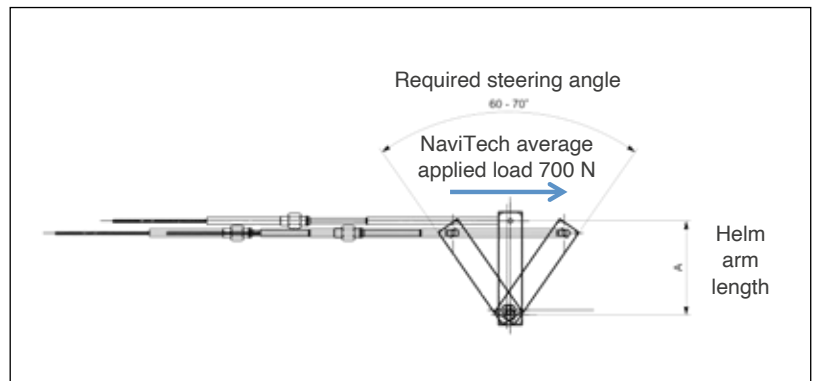



# MECHANICAL STEERING SYSTEM MOUNTING BEZELS



<b>X34</b>	36654B	Black bezel, mounting 90°
<b>X34W</b>	40654C	White bezel, mounting 90°

<b>X35</b>	36655C	Black bezel, mounting 20°
------------	--------	---------------------------



<b>X91</b>	42850N	Chrome plated bezel, mounting 90°
------------	--------	-----------------------------------

<b>X90</b>	42646P	Chrome plated bezel with steering lock device, mounting 90°
------------	--------	---

Model	Bezel included	X34 / X34W	X35	X90	X91
T71FC	-	X	X	-	X
T72FC	-	X	X	-	X
T73NRFC	-	X	X	-	X
T91	-	X	X	X	X
T93ZT	-	X	X	X	X
T87O	-	X	X	X	X
TM87SS	-	X	X	X	X
TM87J	-	X	X	X	X

# ACCESSORIES FOR MECHANICAL STEERING SYSTEMS

## Steering cable supports



**S38**



**S39**



**S40**



**S55**



**OMC-TT**

<b>S38</b>	31971M	Stringer mount clamp block and tube in marine aluminum.
<b>S39</b>	31916F	Clamp block in marine aluminum, stainless steel stud and aluminum anodized tube
<b>S40</b>	31917G	Corrosion resistant splashwell mount flange, aluminum tube
<b>S55</b>	34744A	Corrosion resistant 90° rudder support, stainless steel flange, aluminum tube
<b>OMC® TT</b>	39363H	Thru transom sterndrive steering kit applicable for OMC® sterndrives manufactured from 1968-1982. Connects standard mechanical steering cable to the transom and sterndrive.
<b>S39T</b>	53930J	Aluminum tube only for S39
<b>S40T</b>	53935O	Aluminum tube only for S40

## Engine connection kits



**A75**



**A73SS/A74SS**

<b>A73SS</b>	41255T	Stainless steel tiller arm for some Mercury® engines
<b>A74SS</b>	41256V	Stainless steel tiller arm for some Johnson®, Evinrude®, BRP® engines
<b>A75</b>	34459X	Clevis

**Warning:** A73SS and A74SS tiller arms are recommended for mechanical steering systems only

## Steering cables adaptors



**K46**



**K66**



**1501  
1503**

<b>K46</b>	35679L	Adaptor to connect M47 steering cables (discontinued) to Morse® D290 and Ultraflex® FC type steering helms
<b>K66</b>	38432Q	Adaptor to connect M66 steering cables to Ultraflex® threaded steering helms (discontinued)
<b>1501</b>		5/8-18 stainless steel steering wheel nut
<b>1503</b>		M12 stainless steel steering wheel nut. It adapts GEM®, EDSON® and Uflex wheels while on the Uflex steering shaft
<b>1501B</b>		5/8-18 stainless steel steering wheel nut - black version
<b>1503B</b>		M12 stainless steel steering wheel nut - black version

## WIRE TYPE STEERING GROMMETS AND RINGS

Black	Part No.	Description
R1 B	38060I	Ø 152 mm (6") - h.110 mm (4.3")
R2 B	38061J	Ø 105 mm (4.1"); h 65 mm (2.5")
R3 B	38062K	2 holes- Ø 105 mm (4.1"); h 52 mm (2")

White	Part No.	Description
R1 W	38953A	Ø 152 mm (6") - h.110 mm (4.3")
R2 W	38954C	Ø 105 mm (4.1"); h 65 mm (2.5")
R3 W	38955E	2 holes- Ø 105 mm (4.1"); h 52 mm (2")



R1 B

R2 B

R3 B



R1 W

R2 W

R3 W

### Typical installations

INSTALLATION	CABLE SUPPORT + ENGINE CONNECTION KIT	INSTALLATION	CABLE SUPPORT + ENGINE CONNECTION KIT
A	S39 or S61 or S62 + A75	C	A73SS or A74SS
B	S40 + A75	D	S55 + A75

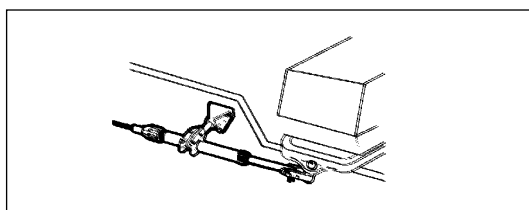

A = With clamp block

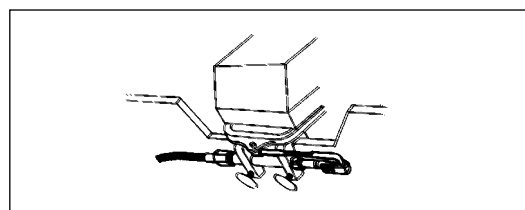

C = With tiller arm

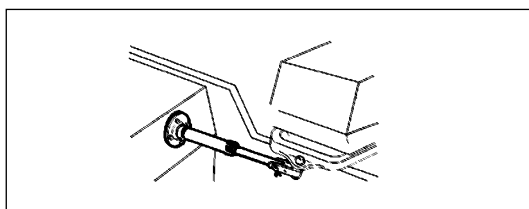

B = With splashwell

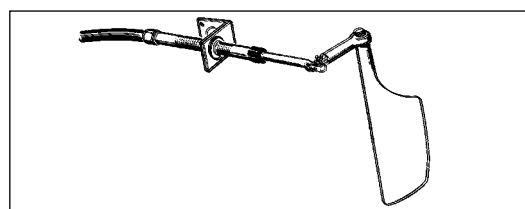

D = With 90° rudder support

### A92

Universal tie bar applicable to twin outboard engines using mechanical or hydraulic steering up to 300 hp maximum total power.

- Easily adjustable before or after installation
- All stainless steel components

**A92/700 Eng center** Adjustable from 550 mm (21.6") to 700 mm (27.5")

**A92/950 Eng center** Adjustable from 700 mm (27.5") to 950 mm (37.4")

<b>A92/700</b>	40892V	Tie bar
<b>A92/950</b>	40893X	Tie bar



A 92

# PACKAGED MECHANICAL STEERING SYSTEMS

A convenient kit form, especially suitable as replacement steering, that includes helm, bezel and cable.  
The cable is available in 1-ft increments from 6 to 30 feet (specify cable length when ordering)

**The wheel is not included**

## ROTECH™

**ROTECH - XLL** - LL= Length  
**T71FC** - helm  
**X34** - 90° bezel  
**M66** - steering cable

**ROTECH - II XLL** - LL= Length  
**T72FC** - helm-dual  
**X34** - 90° bezel  
**M66** - 2 steering cables

Featuring the T71FC helm with a Planetary Gear Design, the Rotech reduces steering effort and delivers more balanced loads on the steering wheel. This unique design also offers a wider wear area which reduces lost motion and improves durability. Centered on the main drive shaft, this helm requires less room behind the dash and is a direct “drop in” replacement for competing system; requiring no new holes for installation.

The Rotech package also includes the M66 Universal Rotary Steering Cable with stainless steel output fittings for maximum longevity and smooth steering.



## ACCURA™

**ACCURA - XLL** - LL= Length  
**T73NR FC** - Zero Torque Feedback helm  
**X34** - 90° bezel  
**M66** - steering cable

With a patented spring clutch the Accura eliminates continuous loads on the steering wheel while the direction of the boat is not being actively changed, which is highly recommended for outboard and stern-drives without power assist.

The T73NRFC Zero Torque Feedback helm included with the Accura package also features a Planetary Gear Design for smooth and more balanced steering effort. A direct drop in replacement for competing systems, the Accura also comes with the M66 Universal Rotary Steering Cable with stainless steel output fittings for maximum longevity and smooth steering.



## FOURTECH™

**FOURTECH - XLL** - LL= Length  
**T91** - helm  
**X34** - 90° bezel  
**M90 Mach** - steering cable

Featuring the T91 high performance helm with a Planetary Gear Design, the Fourtech offers performance, flexibility and durability increased by top quality materials and construction. Centered on the main drive shaft, this helm requires less room behind the dash and is a direct “drop in” replacement for competing system; requires no new holes for installation.

The package includes T91 helm (PLANETARY GEAR DESIGN), bezel and highly flexible M90 Mach cable (patented), also available in black.



# PACKAGED MECHANICAL STEERING SYSTEMS

## FOURTECH-ZTF™

- FOURTECH-ZTF - XLL** - LL= Length
- T93ZT** - helm
- X34** - 90° bezel
- M90 Mach** - steering cable

Featuring the T93ZT high performance Zero Torque Feedback helm with a Planetary Gear Design, the Fourtech offers performance, flexibility and durability increased by top quality materials and construction. Centered on the main drive shaft, this helm requires less room behind the dash and is a direct “drop in” replacement for competing systems; requires no new holes for installation.

The package includes T93ZT (Zero Torque Feedback) helm, bezel and highly flexible M90 Mach cable (patented), also available in black.



## RACKTECH™

- RACKTECH - XLL** - LL= Length
- M86** - preassembled rack and steering cable
- G86** - helm assembly
- X34** - 90° bezel

The Racktech Rack and Pinion steering package offers a compact installation and features the M86 cable with an armor wrapped stainless steel core for maximum efficiency and minimal lost motion.

Ideal for boats with minimal clearance behind the dash, the Racktech is recommended for power assisted sterndrives and other applications with minimal rudder torque.



## RACKTECH™-2.0

- RACKTECH - 2.0**
- TM87O** - preassembled rack and steering cable
- G87** - helm assembly
- X34** - 90° bezel

The Racktech Rack and Pinion steering package offers a compact installation and features the TM87O cable with an armor wrapped stainless steel core for maximum efficiency and minimal lost motion.

Ideal for boats with minimal clearance behind the dash, the Racktech is recommended for power assisted sterndrives and other applications with minimal rudder torque.







**OUTBOARD AND STERNDRIVE  
HYDRAULIC STEERING SYSTEMS**



# UFLEX HYDRAULIC STEERING SYSTEMS

All the components of Uflex hydraulic steering systems are made specifically for the marine environment, using materials and manufacturing processes which offer long life and safety for the most extreme conditions.

## HOW THE SYSTEM WORKS

A manual hydraulic steering system consists of a helm, which pumps hydraulic fluid through two hoses to a hydraulic cylinder which is mounted to an engine or rudder.

While steering, hydraulic oil is pushed through hoses into two chambers within the hydraulic cylinder. Depending upon which direction you steer, one of the two chambers is filled or relieved of oil, thereby changing the course of the boat.

While not actively steering, the torque (hydraulic pressure in the hoses) is held by a one way valve in the helm, which eliminates the transmission of the torque "feedback" to the steering wheel.

The number of turns from full lock-to-lock has a relationship to ease of steering. Generally speaking, the more number of turns lock-to-lock the easier the boat will be to steer and vice versa.

Because of the variety of applications and handling characteristics of boats, the number of turns lock to lock is often a matter of personal preference. As a general rule, the first priority should be ease of steering, then number of turns lock to lock. However, it is not recommended to have fewer than 4 turns lock to lock on high performance boats.

To calculate number of turns lock to lock simply divide the cubic inch displacement of the cylinder by the cubic inch displacement of the helm.

Other factors that can significantly affect the amount of effort to steer the system can be:

- Fittings introduced between the helm and cylinder that restrict fluid efficiency
- Oil viscosity
- Type of hose and inside hose diameter.
- Vessel speed
- Trim angle
- Rudder dimension, or engine power
- Propeller selection
- Hull type (displacement, planing, etc.)
- Sea conditions



# How to select an outboard hydraulic steering system

## Suggestions and warnings

### OUTBOARD CYLINDERS Maximum power rating applicable

Cylinder model	Single engine single cylinder	Double engine single cylinder		Double engine double cylinder	
		NON counter rotating propellers	Counter rotating propellers	NON counter rotating propellers	Counter rotating propellers
	Max hp power	Max hp power	Max hp power	Max hp power	Max hp power
UC81-OBF	115	not applicable	not applicable	not applicable	not applicable
UC95-OBF	175	175	175	not applicable	not applicable
UC128-OBF	300	300	500	500	600
UC128-SVS	350	350	600	600	700
UC130-SVS	350	350	600	600	700
UC132-OBS	250	250	300	300	300

**WARNING:** These recommendations should be used as a general reference only. Final selection should be made with the assistance of a qualified installation technician. For any further information please contact our Technical Service

### STEERING WHEEL TURNS single cylinder

Cylinder model	UP18 18cc	UP20 20cc	UP25 25cc	UP28 28cc	UP33 33cc	UP 39 39cc	UP45 45 cc	UP25-SVS 25cc	UP28-SVS 28cc	UP33-SVS 33cc	UP25-BB 25cc	UP28-BB 28cc	UP33-BB 33cc
UC81-OBF	4.5	-	-	-	-	-	-	-	-	-	-	-	-
UC95-OBF	-	4.7	-	-	-	-	-	-	-	-	-	-	-
UC128-OBF	-	-	5.1	4.3	3.6	3.1	-	-	-	-	-	-	-
UC128-SVS	-	-	-	-	-	-	-	5.1	4.3	3.6	-	-	-
UC130-SVS	-	-	-	-	-	-	-	5.1	4.3	3.6	-	-	-
UC128-BB	-	-	-	-	-	-	-	-	-	-	5.1	4.3	3.6
UC68-OBS	-	3.4/5.0	-	-	-	-	-	-	-	-	-	-	-
UC132-OBS	-	-	5.6/6.9	4.7/5.8	4.0/4.9	3.4/4.2	2.9/3.6	-	-	-	-	-	-
UC133-IOB	-	-	5.6	4.7	4.0	3.4	2.9	-	-	-	-	-	-

Recommended

### STEERING WHEEL TURNS double cylinder

Cylinder model	UP28 28cc	UP33 33cc	UP39 39cc	UP45 45cc	UP33-SVS 33cc	UP39-SVS 39cc
UC128-OBF	-	7.3	6.2	5.3	-	-
UC128 -SVS	-	-	-	-	7.3	6.2
UC130 -SVS	-	-	-	-	7.9	6.7
UC132-OBS	-	8.0/9.8	6.8/8.4	5.8/7.2	-	-
UC133-IOB	-	8.0	6.8	5.8	-	-

Recommended

# Outboard hydraulic steering systems

## SINGLE STATION / SINGLE ENGINE:

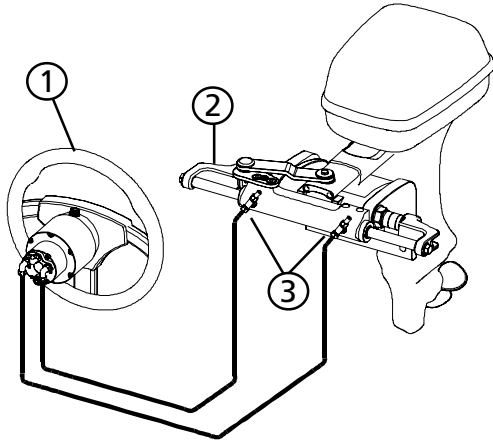

1. helm
2. starboard cylinder
3. bleed valves

## SINGLE STATION / DUAL ENGINE:

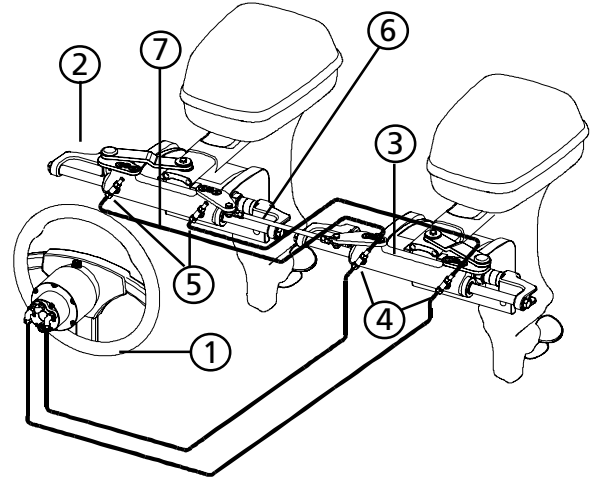

1. helm
2. starboard cylinder
3. port cylinder
4. "T" fittings
5. bleed valves
6. tie bar
7. kit OB-2C (Kit OB-2C130-SVS for SilverSteer™)

## DUAL STATION / SINGLE ENGINE

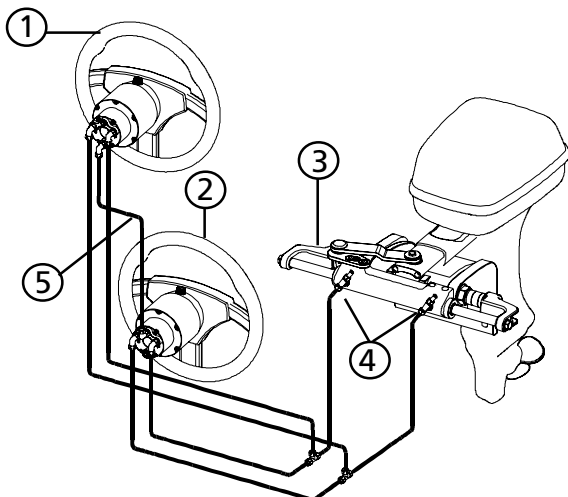

1. upper station helm
2. lower station helm
3. starboard cylinder
4. port cylinder
5. kit OB-2S

## DUAL STATION / DUAL ENGINE

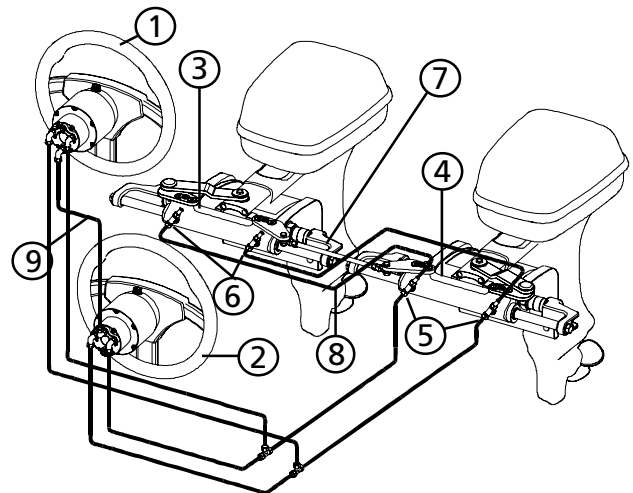

1. upper station helm
2. lower station helm
3. starboard cylinder
4. port cylinder
5. "T" fittings
6. bleed valves
7. tie bar
8. kit OB-2C (Kit OB-2C130-SVS for SilverSteer™)
9. kit OB-2S

## SINGLE STATION / THREE ENGINES

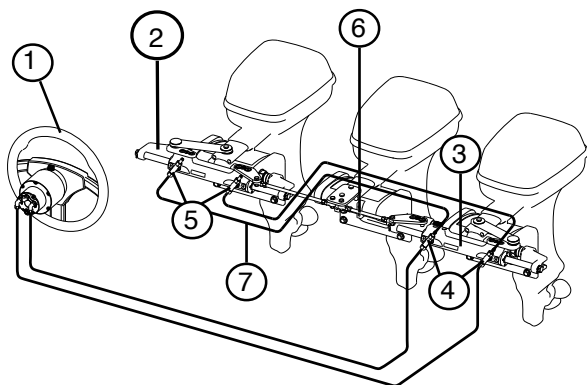

1. helm
2. starboard cylinder
3. port cylinder
4. "T" fittings
5. bleed valves
6. tie bar
7. kit OB-DBR (Kit OB-DBR130-SVS for SilverSteer™)

## SINGLE STATION / FOUR ENGINES

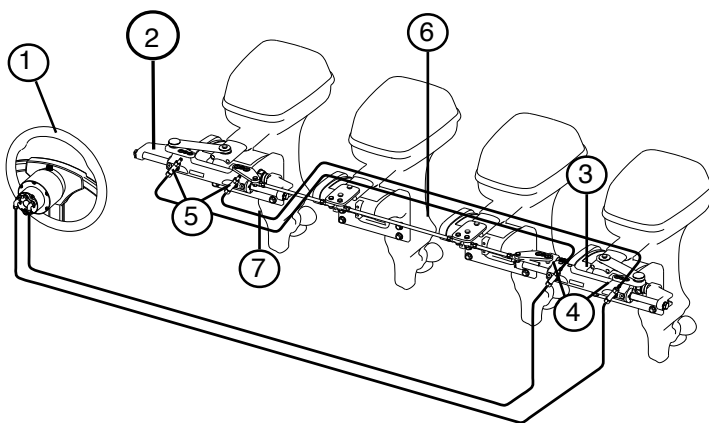

1. helm
2. starboard cylinder
3. port cylinder
4. "T" fittings
5. bleed valves
6. tie bar
7. kit OB-DBR (Kit OB-DBR130-SVS for SilverSteer™)

## DUAL STATION / THREE ENGINES

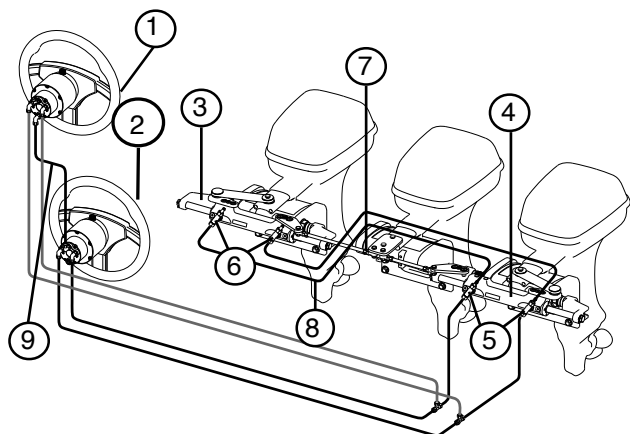

1. upper station helm
2. lower station helm
3. starboard cylinder
4. port cylinder
5. "T" fittings
6. bleed valves
7. tie bar
8. kit OB-DBR (Kit OB-DBR130-SVS for SilverSteer™)
9. kit OB-2S

## DUAL STATION / FOUR ENGINES

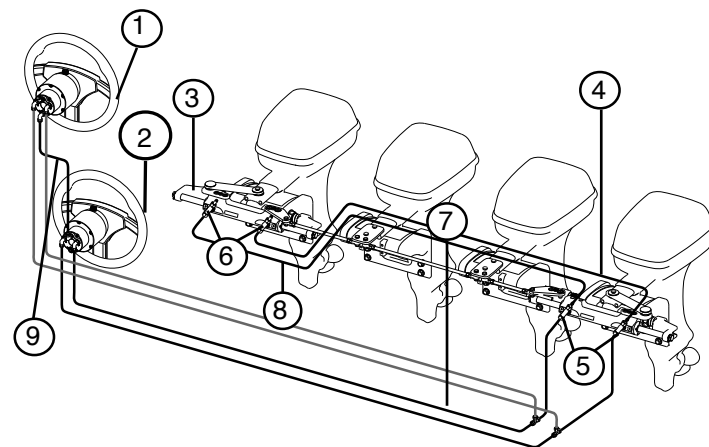

1. upper station helm
2. lower station helm
3. starboard cylinder
4. port cylinder
5. "T" fittings
6. bleed valves
7. tie bar
8. kit OB-DBR (Kit OB-DBR130-SVS for SilverSteer™)
9. kit OB-2S

# Adjustable steering wheel position mechanisms

## Tilt mechanisms

Tilt mechanisms suitable for tilt mount helms



Tilt range of 48° and five locking positions

**new**



X82



X88



X83-SVS

Model	Part No.	Description
X82	43187N	Tilt mechanism for mechanical hydraulic and electronic steering systems
X88	44006L	Tilt mechanism for Masterdrive™ steering systems
X83-SVS	44005J	Tilt mechanism for Silversteer™ steering systems
X82		Compatible with all pumps suitable for X52 (39250U)
X88		Compatible with all pumps suitable for X66 (40613M)
X83-SVS		Compatible with all pumps suitable for X70-SVS (41880T)
The new pumps fit old Tilt X52, X66 and X70 SVS using the new K84 bracket - 44024N		

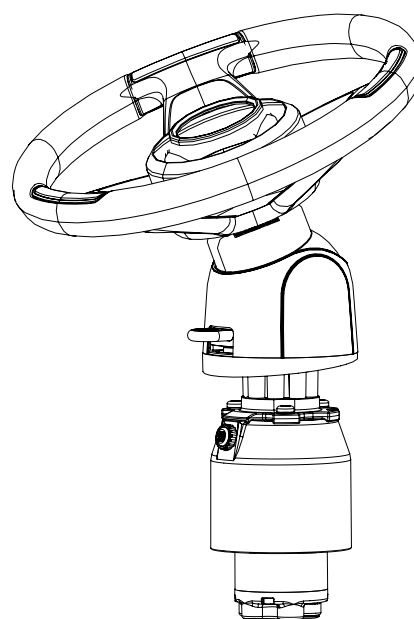

X82, X83-SVS, X88

# Adjustable steering wheel position mechanisms

## Tilt mechanisms

### Tilt mechanism suitable for front mount helms



The only available tilt in the market which can upgrade your standard front mount helm.  
 Minimum space required under the dashboard.  
 Tilt range of 60° and five locking positions.  
 Not applicable to UP18 or UP20 helms



X72

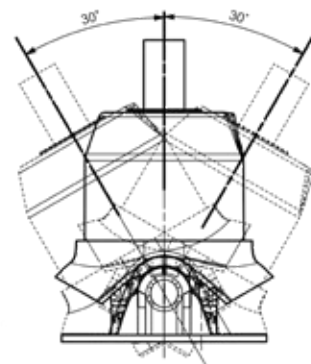

X72	43140K	Tilt mechanism for hydraulic front mount steering systems
-----	--------	---

### Tilt mechanism application for mechanical steering systems

TILT MECHANISM	Part No.	T81, T83NRFC	T101, T103ZT	TM870, TM870ZT, TM87SS, TM87SSZT, TM87J
X82	43187N	X	X	X

### Tilt mechanism application for hydraulic and electronic steering systems

TILT MECHANISM	Part No.	UP18 UP20F	UP20T	FRONT MOUNT HELMS		TILT MOUNT HELMS		MASTERDRIVE	INTEGRA
				STANDARD UP25F, UP28F, UP33F, UP39F, UP45F	SILVERSTEER UP28F-SVS, UP33F-SVS, UP39F-SVS	STANDARD UP25T, UP28T, UP33T, UP39T, UP45T	SILVERSTEER UP28T-SVS, UP33T-SVS, UP39T-SVS		
X52	39250U	-	X	-	-	X	-	-	X
X72	43140K	-	-	X	X	-	-	-	-
X70-SVS	41880T	-	-	-	-	-	X	-	-
X66	40613M	-	-	-	-	-	-	X	-

TILT MECHANISM	PART No.	UP18 UP20F	UP20T 44033P	FRONT MOUNT HELMS		TILT MOUNT HELMS		MASTERDRIVE	INTEGRA
				STANDARD UP25F, UP28F, UP33F, UP39F, UP45F	SILVERSTEER UP28F-SVS, UP33F-SVS, UP39F-SVS	STANDARD UP25T 44028X, UP28T 44027V, UP33T 44026T, UP39T 44025R, UP45T 44029Z	SILVERSTEER UP28T-SVS 44030H, UP33T-SVS 44031K, UP39T-SVS 44032M		
X82	43187N	-	X	-	-	X	-	-	X
X83-SVS	44005J	-	-	-	-	-	X	-	-
X88	44006L	-	-	-	-	-	-	X	-



# UP18

## Intermediate mount position helm



UP18

- Built-in lock valve for positive rudder lock
- Integrated relief valve for over-pressure protection
- 3/4" tapered stainless steel shaft
- Includes 2x 1/4" NPT fittings
- Corrosion proof composite housing
- Easy accessible lock valve and shaft seal for replacement
- For use with UC81-OBF, UC68-OBS and UC69-I cylinders only
- Intermediate mount position helm pump\*

<b>Mounting</b>	intermediate
<b>Displacement / revolution</b>	18 cc- 1.1 cu.in
<b>No. of pistons</b>	5
<b>Relief valve setting</b>	55 Bar - 800 PSI
<b>Max. wheel diameter</b>	508 mm (20")
<b>Weight</b>	3,6 kg (8 lbs")

Model	Part No.	Description
UP18	43182C	Intermediate mount position helm

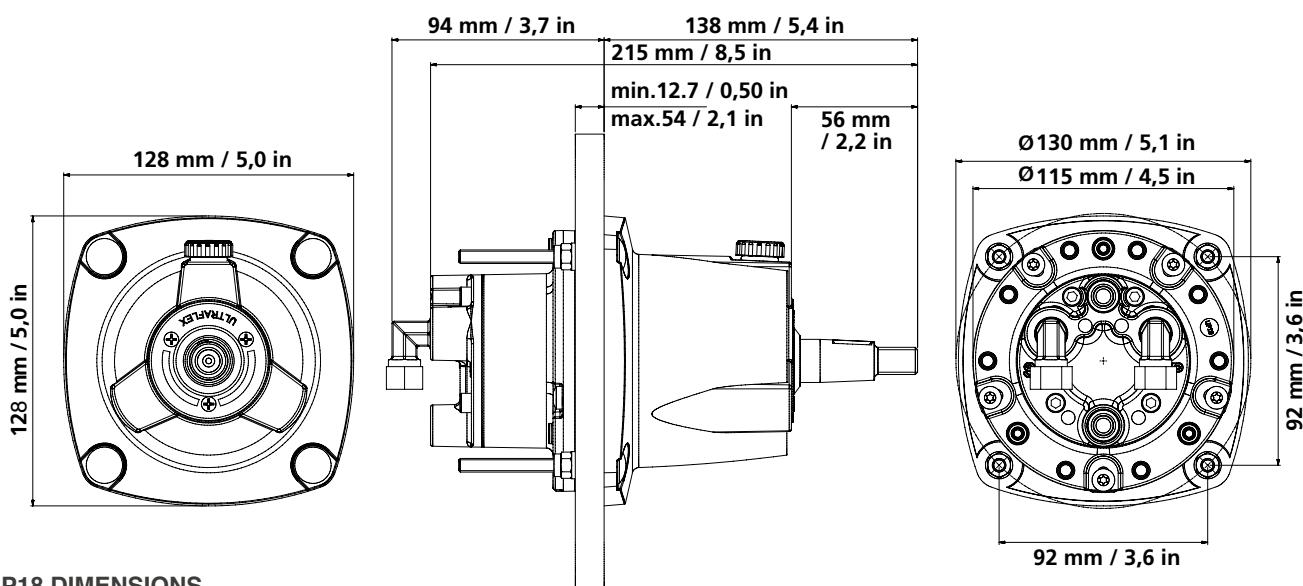

UP18 DIMENSIONS

# UP20F - Front mount helm UP20T - Tilt mount helm



UP20T + X82



UP20F



UP20F + X74

- Built-in lock valve for positive rudder lock
- Integrated relief valve for over-pressure protection
- 3/4" tapered stainless steel shaft
- Corrosion proof composite housing
- Easy accessible lock valve and shaft seal for replacement
- Includes 90° adjustable fittings for 3/8" hose
- **KIT F** - 39664Y (optional): Remote fill adapter
- For use with UC95-OBF, UC68-OBS and UC69-I cylinders only

### For UP20F pump

- **X74** - 43048Y square flange permits to install the UP20F pump in an intermediate dashboard position

### For UP20T pump

- Tilt mechanism: **X82** - 43187N tilt range of 48° and five locking positions

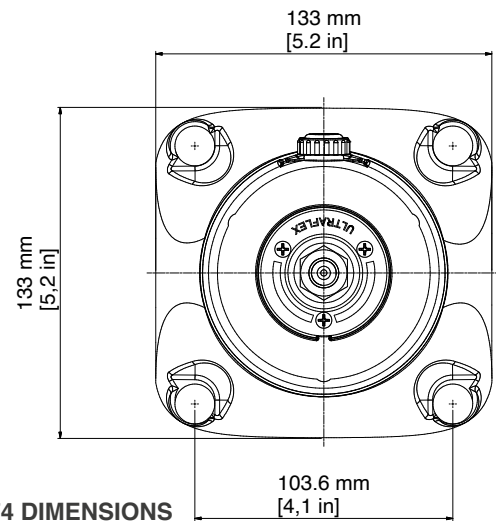

X74 DIMENSIONS

MODEL	P. No.	MOUNTING	DISPLACEMENT/ REVOLUTION	No. OF PISTONS	RELIEF VALVE SETTING	MAXIMUM WHEEL DIA.	WEIGHT
UP20F	43180Y	Front mount	20 cc - 1.2 cu. in	5	70 Bar - 1000 PSI	508 mm - 20"	3.6 kg - 8 lbs
UP20T-X82	44033P + 43187N	With X82 tilt included	20 cc - 1.2 cu. in	5	70 Bar - 1000 PSI	406 mm - 16"	3.9 kg - 8.5 lbs

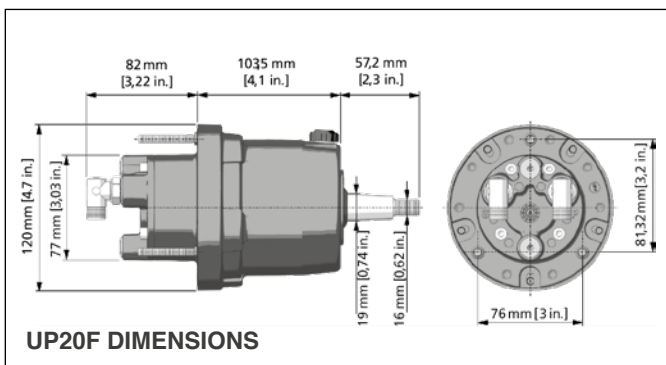

UP20F DIMENSIONS

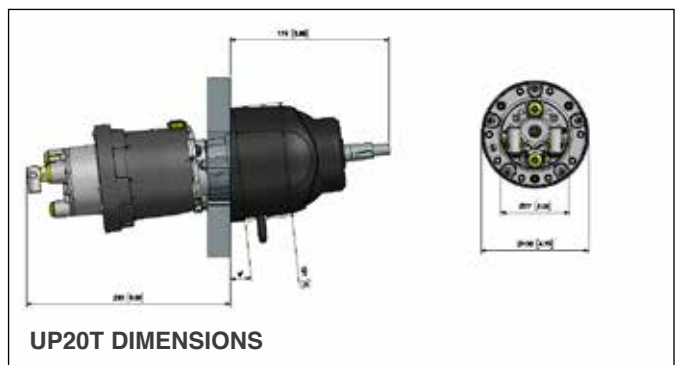

UP20T DIMENSIONS

# UP25F - UP28F - UP33F - UP39F - UP45F

## Front mount helms



X56 square flange

X57 round flange

- Available in five different displacement sizes
- Built-in lock valve for positive rudder lock
- Integrated relief valve for over-pressure protection
- 3/4" tapered stainless steel shaft
- Easy accessible lock valve and shaft seal for replacement
- Cast iron rotor for greater durability and longer life
- Includes 90° adjustable fittings for 3/8" hose
- Ball bearing piston race
- X64 - 40198C square flange or X57 - 39464P round flange to install the helm in a intermediate dashboard position.
- Tilt mechanism: X72 43140K tilt range of 60° and five locking positions



X72 with front mount helm

MODEL	P. No.	MOUNTING	DISPLACEMENT/ REVOLUTION	No. OF PISTONS	RELIEF VALVE SETTING	MAXIMUM WHEEL DIA.	WEIGHT
UP25F	42462D	Front mount	25 cc - 1.5 cu.in	5	70 Bar - 1000 PSI	710 mm - 28"	5 kg - 11 lbs
UP28F	42459R	Front mount	28 cc - 1.7 cu.in	5	70 Bar - 1000 PSI	710 mm - 28"	5 kg - 11 lbs
UP33F	42456J	Front mount	33 cc - 2.0 cu.in	7	70 Bar - 1000 PSI	710 mm - 28"	5 kg - 11 lbs
UP39F	42453C	Front mount	39 cc - 2.4 cu.in	7	70 Bar - 1000 PSI	710 mm - 28"	5 kg - 11 lbs
UP45F	42465K	Front mount	45 cc - 2.7 cu.in	7	70 Bar - 1000 PSI	710 mm - 28"	5 kg - 11 lbs

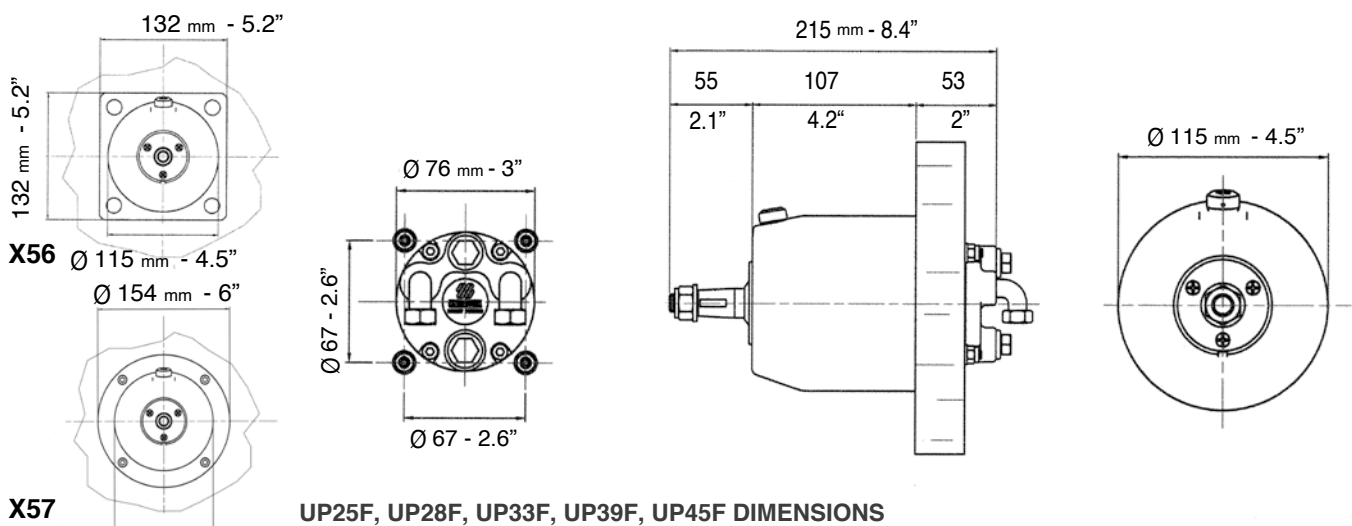

# UP25T - UP28T - UP33T - UP39T - UP45T Tilt mount helms



**X82**

- Available in five different displacement sizes
- Ball bearing piston race
- Built-in lock valve for positive rudder lock
- Integrated relief valve for over-pressure protection
- Stainless steel shaft
- Easy accessible lock valve and shaft seal for replacement
- Cast iron rotor for greater durability and longer life
- Includes 90° adjustable fittings for 3/8" hose
- Tilt mechanism: **X82**- 43187N – tilt range of 48° and five locking positions
- **KIT F** - 39664Y (optional): remote fill adapter

MODEL	PART No.	DISPLACEMENT/ REVOLUTION	No. OF PISTONS	RELIEF VALVE SETTING	MAXIMUM WHEEL DIA.	WEIGHT
<b>UP25T-X82</b>	44107T + 43187N	25 cc - 1.5 cu.in	5	70 Bar - 1000 PSI	406 mm - 16"	5 kg - 11 lbs
<b>UP28T-X82</b>	44027V + 43187N	28 cc - 1.7 cu.in	5	70 Bar - 1000 PSI	406 mm - 16"	5 kg - 11 lbs
<b>UP33T-X82</b>	44026T + 43187N	33 cc - 2.0 cu.in	7	70 Bar - 1000 PSI	406 mm - 16"	5 kg - 11 lbs
<b>UP39T-X82</b>	44025R + 43187N	39 cc - 2.4 cu.in	7	70 Bar - 1000 PSI	406 mm - 16"	5 kg - 11 lbs
<b>UP45T-X82</b>	44029Z + 43187N	45 cc - 2.7 cu.in	7	70 Bar - 1000 PSI	406 mm - 16"	5 kg - 11 lbs

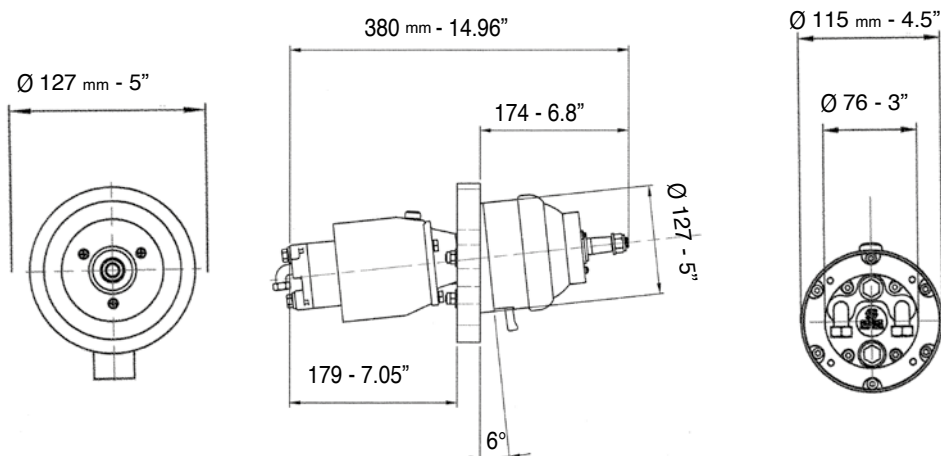

**UP25T, UP28T, UP33T, UP39T, UP45T DIMENSIONS**

# UP28R - UP33R - UP39R - UP45R

## Rear mount helms



- Available in four different displacement sizes
- Compact design
- Ball bearing piston race
- Built-in lock valve for positive rudder lock
- Integrated relief valve for over-pressure protection
- 3/4" tapered stainless steel shaft
- Easily accessible lock valve and shaft seal for replacement
- Cast iron cylinder rotor for greater durability and longer life
- White bezel included
- Complete with 90° adjustable fittings for 3/8" tube, except UP45-IR pump (straight fittings for 12 mm hose)
- **X68** - 40894Z (optional) chrome plated bezel
- **KIT F** - 39664Y (optional): remote fill adapter

MODEL	P. No.	MOUNTING	DISPLACEMENT/ REVOLUTION	No. OF PISTONS	RELIEF VALVE SETTING	MAXIMUM WHEEL DIA.	WEIGHT
UP28R	42460Z	Rear mount	28 cc - 1.7 cu.in	5	70 Bar - 1000 PSI	710 mm - 28"	5 kg - 11 lbs
UP33R	42457L	Rear mount	33 cc - 2.0 cu.in	7	70 Bar - 1000 PSI	710 mm - 28"	5 kg - 11 lbs
UP39R	42454E	Rear mount	39 cc - 2.4 cu.in	7	70 Bar - 1000 PSI	710 mm - 28"	5 kg - 11 lbs
UP45R	42466M	Rear mount	45 cc - 2.7 cu.in	7	70 Bar - 1000 PSI	710 mm - 28"	5 kg - 11 lbs

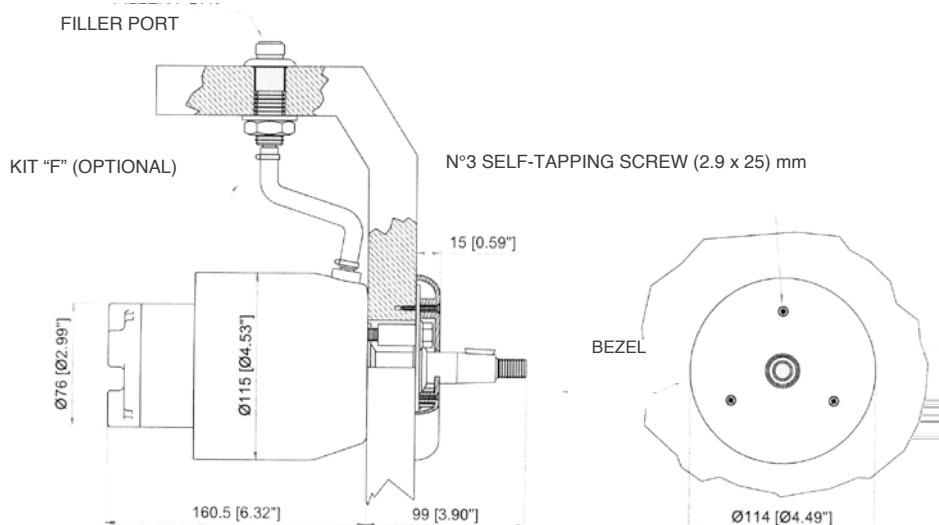

UP28R, UP33R, UP39R, UP45R DIMENSIONS

# UC81-OBF Front mount cylinder



UC81-OBF - Balanced: the number of turns lock-to-lock is equal port to starboard and vice-versa.  
Front mount cylinder for outboard engines up to 115 hp  
Replaceable cylinder end caps

UC81-OBF can be installed port or starboard, according to the applications on the outboard engine

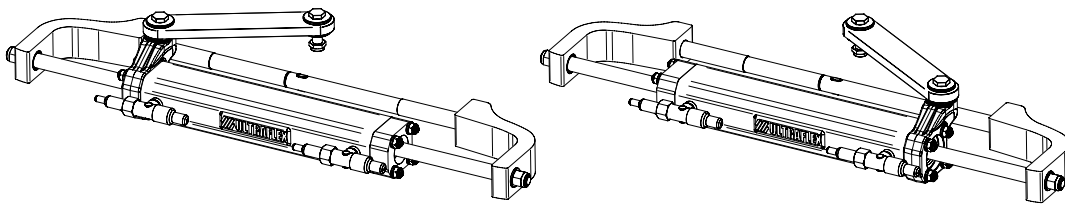

SPECIFICATIONS	UC81-OBF - 42654N
Volume	81 cc - 4.9 cu. in
Output force	222 kg - 489 lbs
Inside diameter	27.4 mm - 1.08"
Stroke	186 mm - 7.3"
3/8" (9,5 mm) Fittings	For high pressure flex hose
Bleed fittings	DN5 Quick connect

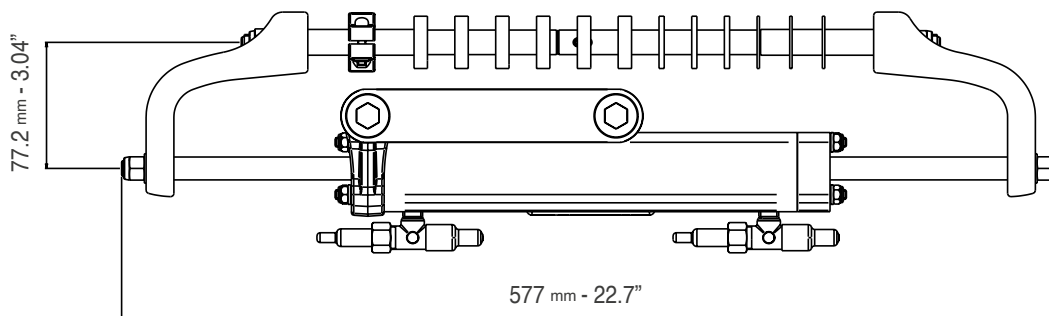

UC81-OBF DIMENSIONS



# UC81-OBF Applications

Single engine up to 115 hp and where the boat speed does not exceed 45 mph (40 knots)

Not intended for use in racing applications

### WARNING

These recommendations should be used as a general reference only. For any further information please contact our Technical Service.

### NOTE:

Suzuki® engines built from 1998 to 2008 installing UC81-OBF cylinder require optional **KIT SU** part No. 41954W.

ENGINE	POWER	YEAR
Mercury® Mariner®	50 – 75 – 90 2S 115 EFI 2S 75 – 90 – 115 Optimax 2S 40 – 50 – 60 EFI 4S 75 – 80 – 90 EFI 4S 100 – 115 EFI 4S	1990-2008 1990-2007 2004-2018 2004-2018 2000-to date 2007-to date
Evinrude®	E40-E50-E55-E60 2S E75-E90 2S E115 2S V4	2004-2020 2004-2020 1995-2020
Yamaha®	60-70 2S 75C-90 2S 115C 2S F40G-F70 4S F30-F40-F60-F75-F80 EFI 4S F90-F100-F115 EFI 4S F115 F80-F100 4S F40D-F50F-F60C EFI 4S	1984-2008 1998-2008 1990-2008 2010-to date 1999-2007 1999-2007 2004-to date 1999-2007 2000-to date
Honda®	BF40-50-60-75-90 4S BF115D BF115A BF90 V-TEC 4S	1995-to date 1998-2009 2009-to date 2008-to date
Suzuki®	DF40-50-60-70-80-90 4S DF100-115 4S DF100-115 4S	1998-to date 1998-2008 2008-to date
Tohatsu® Nissan®	75-115-120-140 2S 40-50-60-70-90-115 TLDI 4S BFT 60-75-80-90-100 4S BFT 115-150 4S 40-50-60-70-90 2S MFS 50-60-75-90-100-115 4S	2004-to date 2004-to date 2015-to date 2015-to date 2004-to date 2018-to date
Selva®	40XS-50 Madeira 2S 40XS-50 Bull shark 2S 40XS-60 Gray shark 2S 40XS-70 Mako Shark 2S 40XS-60 St.Tropez 2S 80 Portofino/Tigershark 2S 25 Kingfish 4S 40 Aruana 4S 40XS-40XSR-50-60 Dorado EFI 4S 40XSR EFI Murena 4S 80XS-100-100XSR EFI Marlin 4S 115-115XSR EFI Tarpon 4S 115 EFI Narwhal 4S	1995-to date          2000-to date
Johnson®	BJ90-115 4S BJ60-70 4S J90-115 V4 2S J150-175 V6 2S	2001-2007 2001-2007 1995-2007 1995-2007
PureCraft®	50 HP	2020-to date
Torque- edo®	Deep Blue 25, 50	2022-to date
Neander Shark®	DTORQUE 111	2020-to date
Parsun®	F40-F50-F60	2007-to date



UC95-OBF/1



UC95-OBF/2



UC95-OBF/3

- UC95-OBF/1 – OBF/2 – OBF/3: Balanced: the number of wheel turns lock-to-lock is equal port to starboard or vice-versa
- Adjustable boss style fittings for easy installation
- High resistance stainless steel connection bolt (ULTRABOLT)
- Replaceable cylinder end caps

**Innovative design (PATENTED):**

- Split and pinned cylinder mounting rod for easy installation and bushings to prevent friction with engine tilt tube

**Applications:**

The UC95-OBF front mount cylinder is recommended for use with outboard engines 175 hp total and where the boat speed does not exceed 55 mph (48 knots)

- Not intended for use in racing applications

**NOTE:** non suitable with starboard link arms LA1, LA2, LA3 for UC128-OBF cylinder.

Model	Part No.	Description
UC95-OBF/1	43515D	Front mount cylinder for outboard engines up to 175 hp total
UC95-OBF/2	43535K	Front mount cylinder for outboard engines up to 175 hp total
UC95-OBF/3	43516F	Front mount cylinder for outboard engines up to 175 hp total

Volume	95 cc - 5.8 cu.in.
Output force	278 kg (613 lbs)
Internal diameter	30 mm (1.18")
Stroke	186 mm (7.3")
Fittings for high pressure flex hose	3/8"
Bleed fittings	DN5 quick disconnect

# UC95-OBF

## Front mount cylinder

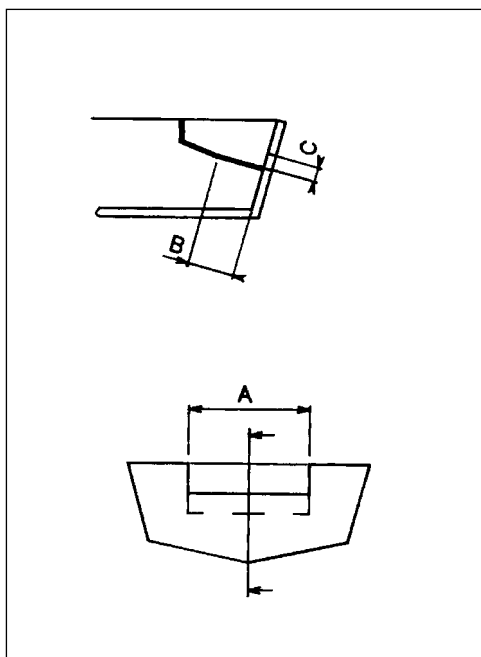
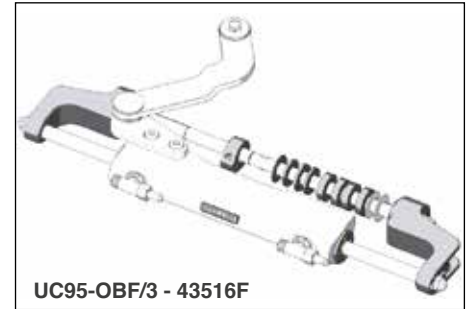
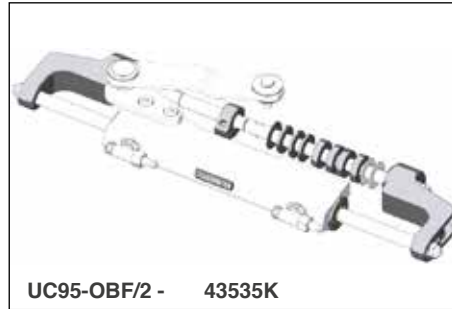
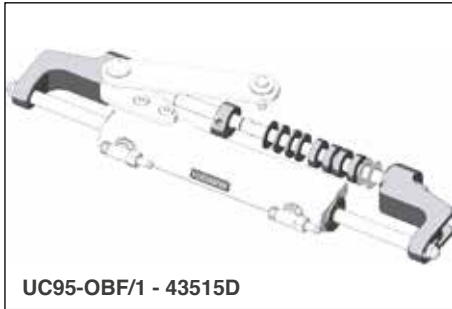

### Splashwell dimension requirements

Engine No.	1
A	540 mm (21.25")
B	152 mm (5.98")
C	152 mm (5.98")

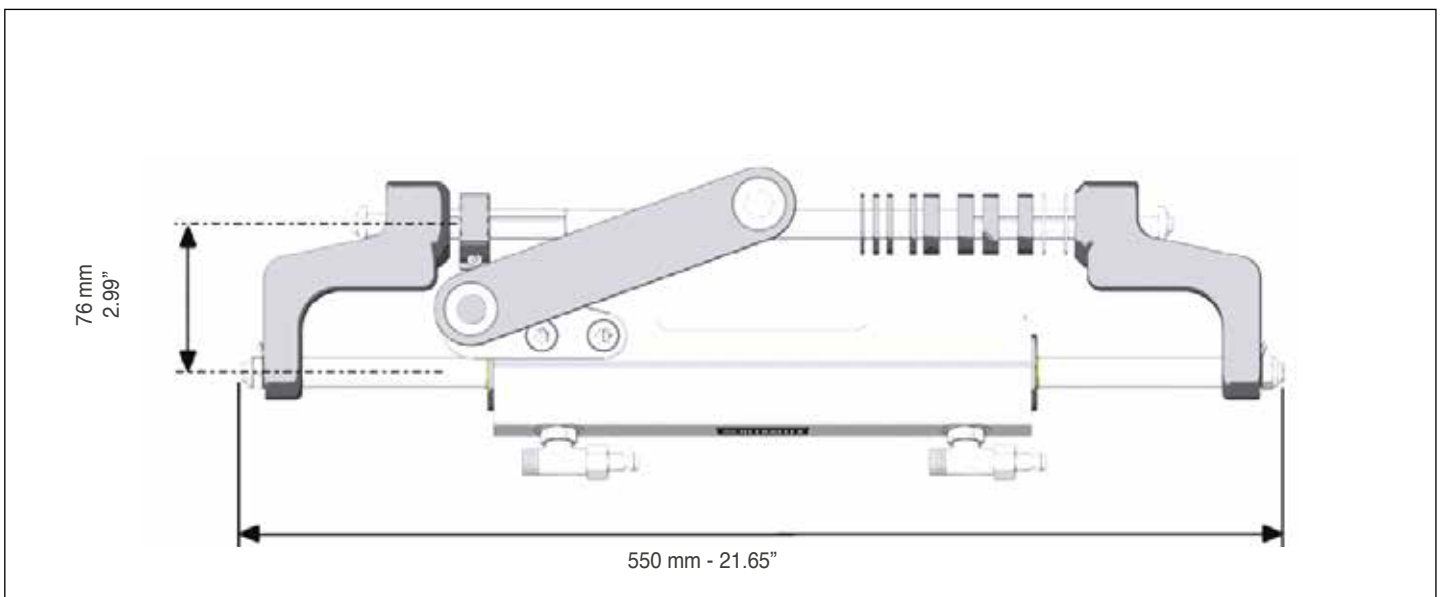

UC95-OBF DIMENSIONS

# UC95-OBF Cylinder applications

ENGINE	MODEL	YEAR	CYLINDER	P. No.
Mercury® Mariner®	100-115-150 EFI 2S	1991-2007	UC95-OBF/1	43515D
	50-75-90 2S	1990-2008	UC95-OBF/1	43515D
	75-90-115 Optimax 2S	2004-2018	UC95-OBF/3	43516F
	125-135-150 -175 Optimax 2S	1999-2018	UC95-OBF/1	43515D
	40-50-60 EFI 4S	2004-to date	UC95-OBF/1	43515D
	75-80-90 EFI 4S / PRO XS / SEAPRO	2000-to date	UC95-OBF/1	43515D
	100-115-150 EFI 4S / PRO XS / SEAPRO	2007-to date	UC95-OBF/1	43515D
	175-V6 4S / SEAPRO	2018-to date	UC95-OBF/1	43515D
Evinrude®	E40-E50-E55-E60 2S	2004-2020	UC95-OBF/1*	43515D
	E75-E90 2 Stroke	2004-2020	UC95-OBF/1*	43515D
	E115-E130 -E135 2 Stroke V4	1995-2020	UC95-OBF/1*	43515D
	E150 -175 2 Stroke V6	1995-2020	UC95-OBF/1*	43515D
Yamaha®	60-70 2S	1984-2008	UC95-OBF/1	43515D
	75C-90 2S	1998-2008	UC95-OBF/1*	43515D
	115C-130B -150F 2S	1990-2008	UC95-OBF/1*	43515D
	150-175 HPDI VMAX 2S	2000-2007	UC95-OBF/1*	43515D
	F60-F75-F80 EFI 4S	1999-2007	UC95-OBF/1	43515D
	F90-F100-F115 F150 EFI 4S	1999-2007	UC95-OBF/1	43515D
	F115-F150-F175 L4 4S	2004-to date	UC95-OBF/1	43515D
Honda®	BF75-80-90-100 4S	1995-to date	UC95-OBF/1	43515D
	BF115D - BF130A	1998-2009	UC95-OBF/3	43516F
	BF115A 4S	2009-to date	UC95-OBF/1	43515D
	BF135-150 4S	2005-to date	UC95-OBF/1	43515D
	BF175-4S	2001-to date	UC95-OBF/1	43515D
Suzuki®	DF70-80-90 4S	1998-to date	UC95-OBF/1*	43515D
	DF100-115-140 4S	2008-to date	UC95-OBF/1	43515D
	DF150-175 4S	2006-to date	UC95-OBF/1	43515D
Tohatsu® Nissan®	115-120-140 2S	2004-to date	UC95-OBF/1*	43515D
	70-90-115 TLDI 4S	2004-to date	UC95-OBF/1	43515D
	BFT60-75-80-90-100 4S	2015-to date	UC95-OBF/1	43515D
	BFT115-150 4S	2015-to date	UC95-OBF/1	43515D
	MFS 50-60-75-90-100-115 4S	2018-to date	UC95-OBF/1	43515D
Selva®	80 Portofino/Tigershark 2S	1995-2008	UC95-OBF/1	43515D
	150 WHITE SHARK 2S	2001-2007	UC95-OBF/1*	43515D
	100EFI Marlin - 115 EFI Narwhal	2001-2007	UC95-OBF/1*	43515D
	100-150EFI Killer Whale 4S	2000-to date	UC95-OBF/1	43515D
Johnson®	BJ90-115-140 4S	2001-2007	UC95-OBF/1	43515D
	BJ70 4S	2001-2007	UC95-OBF/1*	43515D
	J90-115 V4 2S	1995-2007	UC95-OBF/1*	43515D
	J150 -175 V6 2S	1995-2007	UC95-OBF/1*	43515D
Neander Shark®	DTORQUE 111	2020-to date	UC95-OBF/1	43515D
Parsun®	F60-F85-F115	2007-to date	UC95-OBF/1	43515D

**WARNING**  
The UC95-OBF front mount cylinder is recommended for use with outboard engines 175 hp total and less and where the boat speed does not exceed 55 mph (48 knots)

Not intended for use in racing applications

**WARNING**  
These recommendations should be used as a general reference only. For any further information please contact our Technical Service.

**NOTE:**  
Suzuki® engines built from 1998 to 2008 installing UC95-OBF cylinder require optional **KIT SU** part No. 41954W.

\*NOTE: The UC95-OBF/2 (43535K) cylinder allows for a wide tilting angle.

## UC128-OBF

### Front mount cylinder



- UC128-OBF – Balanced: the number of wheel turns lock-to-lock is equal port to starboard or vice-versa
- Adjustable boss style fittings for easy installation
- High resistance stainless steel connection bolt (ULTRABOLT)
- Replaceable cylinder end caps

- UC128-OBF cylinder is built with heavy duty stainless steel cylinder rod, seals and link assemblies, is simple to install and fits almost every 2 and 4 stroke outboard engine on the market.
- UC128-OBF cylinders are recommended for use with UP25, UP28, UP33 and UP39 series helms and preassembled hoses (Kit OB and Kit OB/R5).
- In the applications with dual UC128-OBF cylinder it is necessary to order a standard UC128-OBF cylinder (link arm attached to the starboard side of the cylinder) and a port UC128P-OBF cylinder (link arm attached to the port side of the cylinder). See tie bars section to select the required model for dual engine/dual cylinder applications.

**Applications:** UC128-OBF front mount cylinder is not recommended for use in installations where the boat speed exceeds 55 mph (48 knots) / (65 mph (56 knots) in dual engine, dual cylinder and counter rotating engines application). Not intended for use in racing applications.

Model	Part No.	Description
UC128-OBF/1	43231N	Front mount cylinder, starboard version
UC128-OBF/2	43232R	Front mount cylinder, starboard version
UC128-OBF/3	43233T	Front mount cylinder, starboard version
UC128P-OBF/1	43234V	Front mount cylinder, port version
UC128P-OBF/2	43235X	Front mount cylinder, port version

Volume	120 cc - 7.3 cu.in.
Output force	450 kg (992 lbs)
Internal diameter	35 mm (1.37")
Stroke	185 mm (7.28")
Fittings for high pressure flex hose	3/8"
Bleed fittings	DN5 quick connect

# UC128-OBF Front mount cylinder

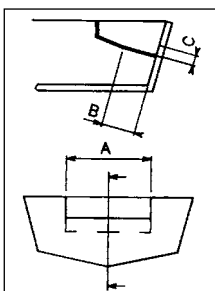
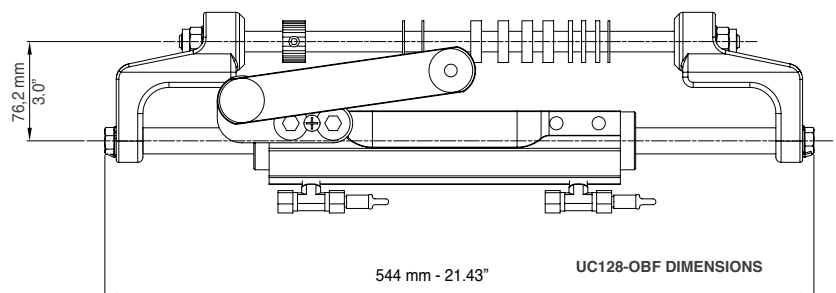
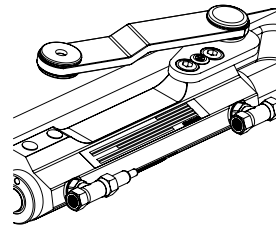
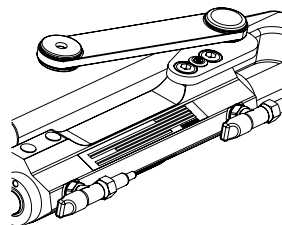
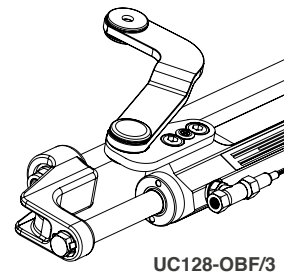
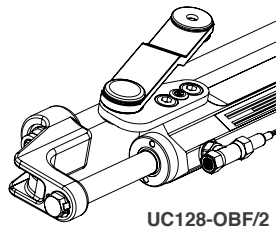
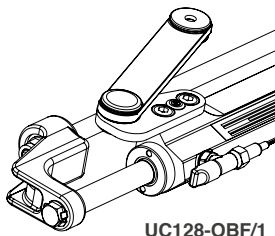

### Splashwell dimension requirements

Engine No.	1	2
A	540 mm (21.25")	1110 mm (43.70")
B	152 mm (5.98")	152 mm (5.98")
C	152 mm (5.98")	152 mm (5.98")

For twin engine applications minimum engine center distance is 650 mm (26")





# UC128-OBF

## Cylinder Applications

ENGINE	MODEL	YEAR	CYLINDER	P. NO.	PACKAGED
Mercury® Mariner®	115-125-150 EFI 2S	1990-2007	UC128-OBF/1	43231N	PROTECH 1.1
	225-250 EFI 2S	2000-2007	UC128-OBF/1	43231N	PROTECH 1.1
	75-90-115 OPTIMAX	2004-2018	UC128-OBF/3	43233T	PROTECH 3.1
	135-150-175 OPTIMAX	1999-2018	UC128-OBF/1	43231N	PROTECH 1.1
	200-225-250 OPTIMAX	1999-2018	UC128-OBF/1	43231N	PROTECH 1.1
	RACING 300 OPTIMAX	1999-2011	UC128-OBF/1	43231N	PROTECH 1.1
	100-115 EFI 4S	2007-to date	UC128-OBF/1	43231N	PROTECH 1.1
	250 SALTWATER EFI 4S	2007-2011	UC128-OBF/1	43231N	PROTECH 1.1
	135-150-175-200 VERADO L4	2004-2012	UC128-OBF/1	43231N	PROTECH 1.1
	FOURSTROKE 175-200 V6	2018-to date	UC128-OBF/1	43231N	PROTECH 1.1
FOURSTROKE 225-300 V8	2018-to date	UC128-OBF/1	43231N	PROTECH 1.1	
Evinrude®	E75-E90 2S	2004-to date	UC128-OBF/2	43232R	PROTECH 2.1
	E115-E130-E135 2S V4	1995-2020	UC128-OBF/2	43232R	PROTECH 2.1
	E150-E175-E200-E225-E250-E300 2S V6	1995-2020	UC128-OBF/2	43232R	PROTECH 2.1
Yamaha®	115C-130B 2S	1990-2008	UC128-OBF/2	43232R	PROTECH 2.1
	75C-90 2S	1998-2008	UC128-OBF/2	43232R	PROTECH 2.1
	F70 4S	2010-to date	UC128P-OBF/1	43234V	PROTECH 1.1
	150F-200F-250G 2S	1990-2008	UC128-OBF/2	43232R	PROTECH 2.1
	150 HPDI VMAX 2S	1996-2007	UC128-OBF/2	43232R	PROTECH 2.1
	175-200-225-250-300 HPDI VMAX 2S	2000-2008	UC128-OBF/2	43232R	PROTECH 2.1
	F115-F150 EFI 4S	2000-2008	UC128-OBF/2	43232R	PROTECH 2.1
	F200-F225-F250 4S	1999-2007	UC128-OBF/2	43232R	PROTECH 2.1
Honda®	BF75-BF90 4S	1995-to date	UC128-OBF/1	43231N	PROTECH 1.1
	BF115-BF130 4S	1998-to date	UC128-OBF/3	43233T	PROTECH 3.1
	BF135-BF150 4S	2005-to date	UC128-OBF/1	43231N	PROTECH 1.1
	BF150 V-TEC 4S	2008-to date	UC128-OBF/1	43231N	PROTECH 1.1
BF175-BF200-BF225-BF250 4S	2001-to date	UC128-OBF/1	43231N	PROTECH 1.1	
Suzuki®	DF70-80-90 4S	1998-to date	UC128-OBF/2	43232R	PROTECH 2.1
	DF100-115-140 4S	2008-to date	UC128-OBF/1	43231N	PROTECH 1.1
	DF150-175-DF200 L4 4S	2006-to date	UC128-OBF/1	43231N	PROTECH 1.1
	DF200-DF225-DF250-DF300-V6 4S	2004-to date	UC128-OBF/2	43232R	PROTECH 2.1
Tohatsu®	115-120-140 2S	2004-to date	UC128-OBF/2	43232R	PROTECH 2.1
	70-90-115 TLDI 4S	2004-to date	UC128-OBF/1	43231N	PROTECH 1.1
	MFS 50-60-75-90-100-115 4S	2018-to date	UC128-OBF/1	43231N	PROTECH 1.1
	BFT 115-150-200-225-250 4S	2014-to date	UC128-OBF/1	43231N	PROTECH 1.1
	BFT60-75-80-90-100 4S	2015-to date	UC128-OBF/1	43231N	PROTECH 1.1
Selva®	80 PORTOFINO/TIGERSHARK 2S	1995-2008	UC128-OBF/1	43231N	PROTECH 1.1
	150 WHITE SHARK 2S	2001-2007	UC128-OBF/2	43232R	PROTECH 2.1
	100EFI MARLIN-115 EFI NARWHAL	2000-to date	UC128-OBF/2	43232R	PROTECH 2.1
	225 BEAKED WHALE 4S	2019-to date	UC128-OBF/2	43232R	PROTECH 2.1
	100-150EFI KILLER WHALE 4S-200 SEI WHALE 4S	2000-to date	UC128-OBF/1	43231N	PROTECH 1.1
Johnson®	BJ90-115-140 4S	2001-2007	UC128-OBF/1	43231N	PROTECH 1.1
	J90-115 V4 2S	1995-2007	UC128-OBF/2	43232R	PROTECH 2.1
	J150-175 V6 2S	1995-2007	UC128-OBF/2	43232R	PROTECH 2.1
	J200-225 V6 4S	2004-2007	UC128-OBF/2	43232R	PROTECH 2.1
OXE®	125-150-175-200HP DIESEL	2018-to date	UC128-OBF/1	43231N	PROTECH 1.1
	300HP DIESEL	2020-to date	UC128-OBF/1	43231N	PROTECH 1.1
COX®	300HP	2020-to date	UC128-OBF/2	43232R	PROTECH 2.1
Neander Shark®	DTORQUE 111	2018-to date	UC128-OBF/1	43231N	PROTECH 1.1
Parsun®	F300	2023-to date	UC128-OBF/2	43232R	PROTECH 2.1

**WARNING**  
These recommendations should be used as a general reference only. Final selection should be made with the assistance of a qualified installation technician. For any further information please contact our Technical Service.

For higher horsepower applications, high performance SilverSteer™ cylinder is recommended.

SYSTEM	APPLICATION	WHEEL TURNS	COMPONENTS	MODEL	Q.TY	
<b>Single engine Single cylinder</b>  	Up to 300 hp max	4,8 (UP25)	Cylinder	UC128-OBF	1	
			Helm pump	UP25 or UP28	1	
			Hose Kit	KIT OB	1	
			Oil	OIL 15	2	
			Steering wheel	(Wheel selection)	1	
<b>For a second station add:</b> 1 UP25 or UP28 helm pump, 1 KIT OB-2S fitting kit, 1 KIT OB, 1 OIL 15, 1 steering wheel						
<b>Dual engine Single cylinder</b>  	Up to 300 hp max (non-counter rotating engine)	4,8 (UP25)	Cylinder	UC128-OBF	1	
			Helm pump	UP25 or UP28	1	
	Up to 500 hp max (counter rotating engine)		Hose Kit	KIT OB	1	
			Oil	OIL 15	2	
			Tie bar	A96	1	
	Steering wheel	(Wheel selection)	1			
<b>For a second station add:</b> 1 UP25 or UP28 helm pump, 1 KIT OB-2S fitting kit, 1 KIT OB, 1 OIL 15, 1 steering wheel						
<b>Dual engine Dual cylinder</b>  	Up to 500 hp max (non-counter rotating engines)	6,1 (UP39)	Cylinder	UC128-OBF	1	
				Cylinder Port	UC128P-OBF	1
				Helm pump	UP39 or UP45	1
	Up to 600 hp max (counter rotating engines)		Hose Kit	KIT OB	1	
			Oil	OIL 15	3	
			Tie bar	A95	1	
			Steering wheel	(Wheel selection)	1	
	Connection Kit	KIT OB-DBR	1			
<b>For a second station add:</b> 1 UP39 or UP45 helm pump, 1 KIT OB-2S fitting kit, 1 KIT OB, 2 T fittings 39502 V, 1 OIL 15, 1 steering wheel						

## WARNING

The UC128-OBF front mount cylinder is not recommended for use in installations where the boat speed exceeds **55 mph (48 knots)** 65 mph (56 knots) in dual engine, dual cylinder and counter rotating engines application. Not intended for use in racing applications.

## Dual engine dual cylinder application diagram

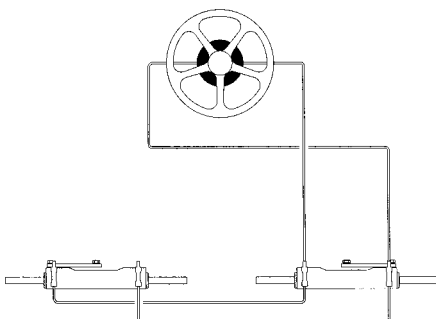

### NOTE:

Three outboard engine applications are available with UC130-SVS cylinder.

**For triple outboard engine, dual cylinder applications, please refer to tie-bar section.**

For any further and detailed information, please contact our Technical Service.

### NOTE:

For high performance applications SilverSteer™ systems are recommended.

# UC132-OBS side mount cylinder

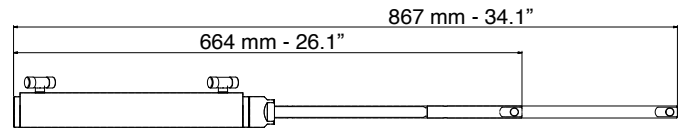

UC132-OBS

UC132-OBS Unbalanced: the wheel number of turns lock-to-lock is not equal port to starboard and vice-versa

- This side mount cylinder features a turning nut for a fast and easy installation to the engine tube (PATENTED)
- Clearance required at the engine tube side: 375 mm (14.76")

APPLICATIONS: not recommended for use in installations where the boat speed exceeds 55 mph (48 knots) or 60 mph (52 knots) for dual cylinder / dual engines installations  
Not intended for use in racing applications

WARNING: UC132-OBS cylinder is not intended for use with 105 Bar (1500 PSI) SilverSteer series helms.

Volume	132/163 cc - 8/9.95 cu.in.
Output force	464/574 kg (1023/1265 lbs)
Internal Diameter	25 mm (0.98")
Corsa	203 mm (8")
Fittings for high pressure flex hose	3/8"

Model	Part No.	Description
UC132-OBS	39430W	Side mount Cylinder

ORDER GUIDE	SYSTEM	APPLICATION	WHEEL TURNS	COMPONENTS	MODEL	Q.TY
	Single engine Single cylinder	Up to 250 hp max	5,3/6,5 (UP25)	Cylinder Helm pump Hose Kit	UC132-OBS UP25 or UP28 KIT OB	1 1 1
			4,7/5,8 (UP28)	Oil Steering wheel	OIL 15 (Wheel selection)	2 1
For a second station add: 1 UP25 or UP28 helm pump, 1 KIT OB-2S fitting kit, 1 KIT OB, 1 OIL 15, 1 steering wheel						
	Dual engine Single cylinder	Up to 250 hp max (non-counter rotating engine)  Up to 300 hp max (counter rotating engine)	5,3/6,5 (UP25)	Cylinder Helm pump Hose Kit	UC132-OBS UP25 or UP28 KIT OB	1 1 1
			4,7/5,8 (UP28)	Oil Tie bar Steering wheel	OIL 15 (Universal tiller-to-tiller tie bar) (Wheel selection)	2 1 1
For a second station add: 1 UP25 or UP28 helm pump, 1 KIT OB-2S fitting kit, 1 KIT OB, 1 OIL 15, 1 steering wheel						
	Dual engine Dual cylinder	Up to 300 hp max (non-counter rotating engines)  Up to 300 hp max (counter rotating engines)	6,7/8,3 (UP39)	Cylinder Helm pump Hose Kit	UC132-OBS UP39 or UP45 KIT OB	2 1 1
			5,8/7,3 (UP45)	Oil Tie bar Steering wheel Connection Kit	OIL 15 (Universal tiller-to-tiller tie bar) (Wheel selection) KIT OB-DBR	3 1 1 1
For a second station add: 1 UP39 or UP45 helm pump, 1 KIT OB-2S fitting kit, 1 KIT OB, 2 tee fittings 39502 V, 1 OIL 15, 1 steering wheel						
<b>WARNING: THIS APPLICATION REQUIRES THAT THE THREADS ON THE TILT TUBE EXTEND AT LEAST 0.6" (15 mm) FROM BOTH SIDES.</b>						

# High pressure flexible hoses

## KIT OB AND KIT OB-BHBR: HYDRAULIC HOSE KITS

Two high pressure flexible hoses with pre-crimped nickel plated fittings, bulkhead fittings (for KIT OB-BHBR only) and bend restrictors on one end. Recommended for use with all Uflex helms with 1000 psi relief valve.



KIT OB	KIT OB-BHBR	LENGTH
KIT OB-06	KIT OB-BHBR-06	6'
KIT OB-08	KIT OB-BHBR-08	8'
KIT OB-10	KIT OB-BHBR-10	10'
KIT OB-12	KIT OB-BHBR-12	12'
KIT OB-14	KIT OB-BHBR-14	14'
KIT OB-16	KIT OB-BHBR-16	16'
KIT OB-18	KIT OB-BHBR-18	18'
KIT OB-20	KIT OB-BHBR-20	20'
KIT OB-22	KIT OB-BHBR-22	22'
KIT OB-24	KIT OB-BHBR-24	24'
KIT OB-26	KIT OB-BHBR-26	26'
KIT OB-28	KIT OB-BHBR-28	28'
KIT OB-30	KIT OB-BHBR-30	30'



KIT OB



KIT OB-BHBR

## KIT OB/M - Hose kit with preassembled fittings at one end - single station application

It consists of a pair of high pressure flexible hose with fittings featuring turning nuts preassembled at one end only. It is supplied with 2 non assembled fittings and 2 reinforcing sleeves. Not recommended for use with SilverSteer™ and MasterDrive™ helms (1500 psi). Available on three lengths that can be cut to fit the desired application.

KIT OB/M	LENGTH	P. No.
KIT OB/M-20	6,00 m - 20 ft	41708E
KIT OB/M-30	9,00 m - 30 ft	41709G
KIT OB/M-50	15,00 m - 50 ft	42565P



KIT OB/M

## KIT OB-DBR: DUAL CYLINDER/ DUAL ENGINE CONNECTION KIT

Two high pressure flexible hoses, with pre-crimped fittings and bend restrictors on both ends.

Five lengths available: 2', 2.5', 3', 4', 5'

KIT OB-DBR	LENGTH
KIT OB-DBR-02	2'
KIT OB-DBR-025	2.5'
KIT OB-DBR-03	3'
KIT OB-DBR-04	4'
KIT OB-DBR-05	5'



KIT OB-DBR



## KIT OB-2S: FITTINGS FOR A SECOND STEERING STATION OR AUTOPILOT INSTALLATION

It includes all necessary fittings and 7.6 m (25 ft) of 3/8" dia. nylon tube for the compensating line

KIT OB-2S - 39539V



KIT OB-2S

## STANDARD OUTBOARD HYDRAULIC STEERING SYSTEMS PACKAGED IN A BOX

### GOTECH wheel turns 4.5



GOTECH

Specifically designed to fit the tight cowling clearances and space constraints of smaller horsepower engines, the GoTech is the most affordable hydraulic steering for engines under 115hp. The mid-mount UP18 helm positions the steering wheel close to the height of a mechanical steering helm.

#### For outboard engines up to 115 hp

GOTECH package kit contains:

<b>UP18</b>	Intermediate mount helm pump
<b>UC81-OBF</b>	Front mount outboard cylinder
<b>OIL 15</b>	Hydraulic oil – 2 quarts.
<b>TU95</b>	Hose kit dia. 3/8" 30 ft length

### HYTECH wheel turns 4.7



HYTECH

#### For outboard engines up to 175 hp

HYTECH package kit contains:

<b>UP20F</b>	Front mount helm pump.
<b>UC95-OBF</b>	Front mount outboard cylinder <i>Specify engine type when ordering:</i>
<b>HYTEC 1.1</b>	- with UC95-OBF/1 cylinder
<b>HYTEC 2.1</b>	- with UC95-OBF/2 cylinder
<b>HYTEC 3.1</b>	- with UC95-OBF/3 cylinder

**OIL 15** Hydraulic oil - 2 quarts.

**KIT OB OPTIONAL** Hose kit with preassembled fittings *Specify length required when ordering*

**WARNING:** Depending on the applications, the UC95-OBF is available in 3 versions: UC95-OBF/1, UC95-OBF/2 and UC95-OBF/3.

UC95-OBF/1 cylinder is not suitable for HONDA® BF115 and BF130 engines and Mercury® Optimax™ 75, 90, 115. For these engines UC95-OBF/3 is available.

# STANDARD OUTBOARD HYDRAULIC STEERING SYSTEMS PACKAGED IN A BOX

## HYTECH-OBF/M wheel turns 4.7



HYTECH-OBF/M

### For outboard engines up to 175 hp

HYTECH-TU95 package kit contains:

- UP20F** Front mount helm pump.
- UC95-OBF** Front mount outboard cylinder *Specify engine type when ordering.*
  - HYTEC-OBF/M 1.1** - with UC95-OBF/1 cylinder
  - HYTEC-OBF/M 2.1** - with UC95-OBF/2 cylinder
  - HYTEC-OBF/M 3.1** - with UC95-OBF/3 cylinder
- OIL 15** Hydraulic oil - 2 quarts.
- KIT OB/M-20** 40 ft (12,2 m) 3/8" nylon tubing

**WARNING:** Depending on the applications, the UC95-OBF is available in 3 versions:

UC95-OBF/1, UC95-OBF/2 and UC95-OBF/3.

UC95-OBF/1 cylinder is not suitable for HONDA® BF115 and BF130 engines and Mercury® Optimax™ 75, 90, 115. For these engines UC95-OBF/3 is available.

## PROTECH wheel turns 4.29



PROTECH

PROTECH package kit contains:

- UP28F** Front mount helm pump.
- UC128-OBF** Front mount outboard cylinder. *Specify engine type when ordering.*
  - PROTECH 1.1** - with UC128-OBF/1 cylinder
  - PROTECH 2.1** - with UC128-OBF/2 cylinder
  - PROTECH 3.1** - with UC128-OBF/3 cylinder

**OIL 15** Hydraulic oil - 2 quarts .

**KIT OB OPTIONAL** Hose kit with preassembled fittings - *Specify length required when ordering*

Durability and performance define the Protech front mount outboard steering package. From the stainless steel helm shaft, heavy duty shaft seals, carbon steel piston and 304 electropolished and passivated stainless link assemblies, the Protech is built for maximum longevity and peak performance. Adjustable boss style fittings allow precise hose routing without the risk of breaking the fittings by over tightening.



# UP25F-SVS - UP33F-SVS - UP39F-SVS

## High Performance front mount helms



X72

SilverSteer™ SVS helms have been specifically designed for high torque outboard applications such as boats with shallow dead rise and high horsepower engines.

Featuring a 1500 psi ( 105 Bar ) pressure valve, SilverSteer™ helms will deliver very precise steering at all torque loads. The SVS helms have to be coupled with the UC128-SVS cylinders and the Kit OB-SVS hoses, which are also specifically designed for high torque applications. SVS Helm pumps feature stainless steel shafts and 90° adjustable nickel-plated brass fittings.

- Available in three different displacement sizes
- Compact design
- Ball bearing piston race
- Built-in lock valve for positive rudder lock
- **Integrated relief valve for over-pressure protection 105 bar (1500 psi)**
- 3/4" tapered stainless steel shaft
- Easily accessible lock valve and shaft seal for replacement
- Cast iron rotor for greater durability and longer life
- Complete with 90° adjustable fittings for 3/8" hose
- Tilt mechanism:

X72 - 43140K (sold separately) Tilt range of 60° and five locking positions.

**WARNING:** SilverSteer™ helm pumps are always to be installed in conjunction with the UC128-SVS or UC130-SVS cylinders and the Kevlar reinforced hose kit KIT OB-SVS.

MODEL	P. No.	MOUNTING	DISPLACEMENT/ REVOLUTION	No. OF PISTONS	RELIEF VALVE SETTING	MAXIMUM WHEEL DIA.	WEIGHT
UP25F-SVS	42841M	Front mount	25 cc - 1.5 cu.in	5	105 bar - 1500 PSI	710 mm - 28"	5 kg - 11 lbs
UP33F-SVS	42661K	Front mount	33 cc - 2.0 cu.in	7	105 bar - 1500 PSI	710 mm - 28"	5 kg - 11 lbs
UP39F-SVS	42660H	Front mount	39 cc - 2.4 cu.in	7	105 bar - 1500 PSI	710 mm - 28"	5 kg - 11 lbs

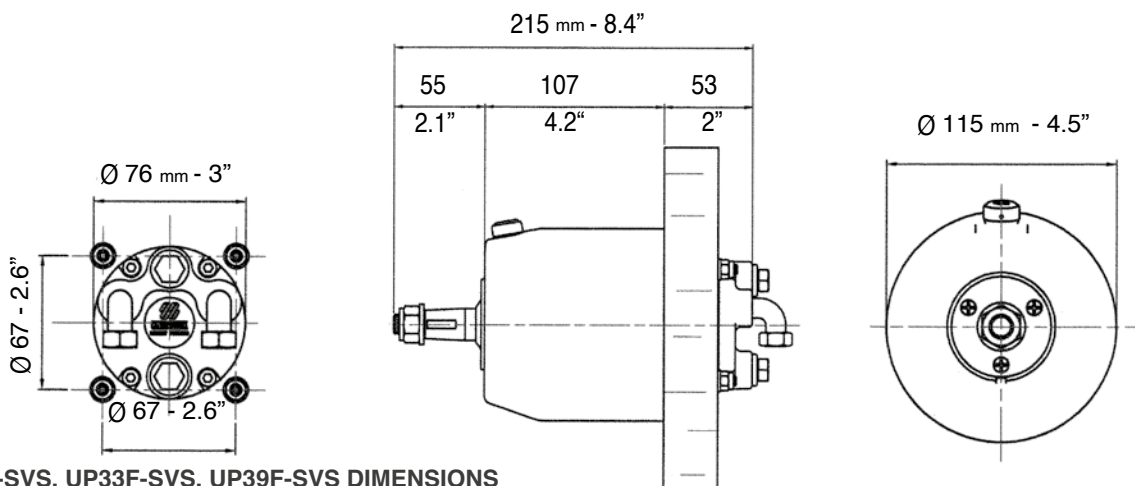

UP25F-SVS, UP33F-SVS, UP39F-SVS DIMENSIONS

# UP25T-SVS - UP33T-SVS - UP39T-SVS

## High Performance tilt mount helms



X83-SVS



SilverSteer™ SVS helms have been specifically designed for high torque outboard applications such as bass boats, and boats with shallow dead rise and high horsepower engines.

Featuring a 1500 psi (105 Bar) pressure valve, SilverSteer™ helms will deliver very precise steering at all torque loads.

The SVS helms have to be coupled with the UC128SVS cylinders and the Kit OB-SVS hoses, which are also specifically designed for high torque applications.

SVS Helm pumps feature stainless steel shafts and 90° adjustable nickel-plated brass fittings.

- Available in three different displacement sizes
- Compact design
- Ball bearing piston race
- Built-in lock valve for positive rudder lock (patented)
- Integral relief valve for over-pressure protection 105 bar (1500 psi)
- Stainless steel shaft
- Easily accessible lock valve and shaft seal for replacement
- Cast iron rotor for greater durability and longer life
- Complete with 90° adjustable fittings for 3/8" hose
- Tilt mechanism for SilverSteer™ systems: **X83-SVS** - 44005J– Tilt range of 48° and five locking positions
- **KIT F** - 39664Y (optional): remote fill adapter

**WARNING:** The SilverSteer™ helm pumps are always to be installed in conjunction with the UC130-SVS cylinder and the Kevlar reinforced hose kit KIT OB-SVS.

MODEL	P. No.	DISPLACEMENT/ REVOLUTION	No. OF PISTONS	RELIEF VALVE SETTING	MAXIMUM WHEEL DIA.	WEIGHT
UP25T-SVS+X83-SVS	44195T + 44005J	25 cc - 1.5 cu.in	5	105 Bar - 1500 PSI	406 mm - 16"	5 kg - 11 lbs
UP33T-SVS+X83-SVS	44031K + 44005J	33 cc - 2.0 cu.in	7	105 Bar - 1500 PSI	406 mm - 16"	5 kg - 11 lbs
UP39T-SVS+X83-SVS	44032M + 44005J	39 cc - 2.4 cu.in	7	105 Bar - 1500 PSI	406 mm - 16"	5 kg - 11 lbs

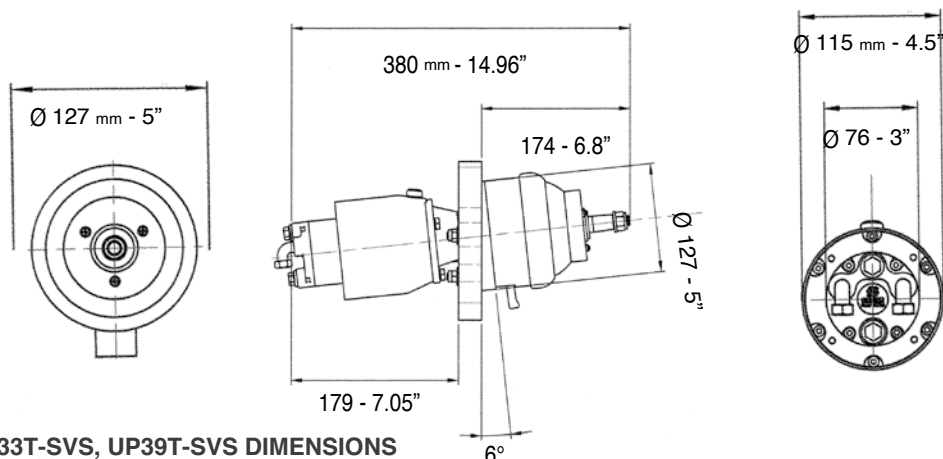

UP25T-SVS, UP33T-SVS, UP39T-SVS DIMENSIONS

# UP25FM-BB - UP28FM-BB - UP33FM-BB

## Top performance front mount helms for bass boats



The **UP-BB** series of helms are specifically designed for bass boat applications where a quick response is needed. These boats typically have high horsepower motors with high torque. The vessels are typically fast with very shallow deadrise. This is the racecar of helms that's tight and responsive. Featuring a 1500 psi ( 105 Bar ) pressure valve, UP-BB helms will deliver very precise steering at all torque loads. The UP-BB helms have to be coupled with the UC128-SVS cylinder and the Kit OB-SVS hoses, which are also specifically designed for high torque applications. UP-BB Helm pumps feature stainless steel shafts and 90° adjustable nickel-plated brass fittings.

- Available in three different displacement sizes
- Quick response valve
- Compact design
- Ball bearing piston race
- Built-in lock valve for positive rudder lock
- **Integrated relief valve for over-pressure protection 105 bar (1500 psi)**
- 3/4" tapered stainless steel shaft
- Easily accessible lock valve and shaft seal for replacement
- Cast iron rotor for greater durability and longer life
- Complete with 90° adjustable fittings for 3/8" hose

**WARNING:** UP-BB helm pumps are always to be installed in conjunction with the UC128-SVS cylinder and the Kevlar reinforced hose kit KIT OB-SVS.

MODEL	P. No.	MOUNTING	DISPLACEMENT/ REVOLUTION	No. OF PISTONS	RELIEF VALVE SETTING	MAXIMUM WHEEL DIA.	WEIGHT
UP25FM-BB	43926B	Front mount	25 cc - 1.7 cu.in	5	105 bar - 1500 PSI	710 mm - 28"	5 kg - 11 lbs
UP28FM-BB	43925Z	Front mount	28 cc - 2.0 cu.in	5	105 bar - 1500 PSI	710 mm - 28"	5 kg - 11 lbs
UP33FM-BB	43832S	Front mount	33 cc - 2.4 cu.in	7	105 bar - 1500 PSI	710 mm - 28"	5 kg - 11 lbs

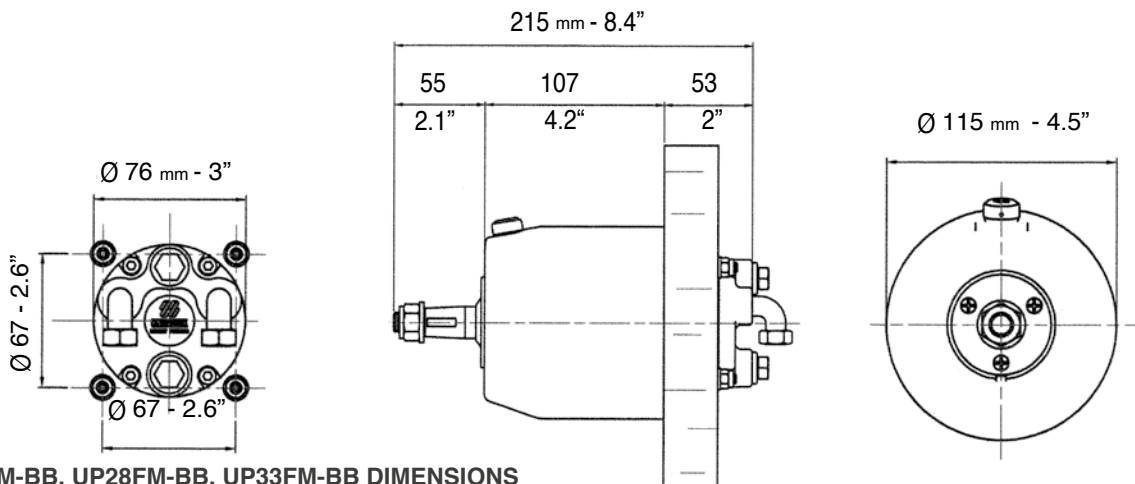

UP25FM-BB, UP28FM-BB, UP33FM-BB DIMENSIONS

# UP25T-BB - UP28T-BB - UP33T-BB

## Top Performance tilt mount helms for bass boats



X83-SVS



The **UP-BB** series of helms are specifically designed for bass boat applications where a quick response is needed. These boats typically have high horsepower motors with high torque. The vessels are typically fast with very shallow deadrise. This is the racecar of helms that's tight and responsive. Featuring a 1500 psi ( 105 Bar ) pressure valve, UP-BB helms will deliver very precise steering at all torque loads. The UP-BB helms have to be coupled with the UC128-SVS cylinder and the Kit OB-SVS hoses, which are also specifically designed for high torque applications. UP-BB Helm pumps feature stainless steel shafts and 90° adjustable nickel-plated brass fittings.

- Available in three different displacement sizes
- Quick response valve
- Compact design
- Ball bearing piston race
- Built-in lock valve for positive rudder lock (patented)
- Integral relief valve for over-pressure protection 105 bar (1500 psi)
- Stainless steel shaft
- Easily accessible lock valve and shaft seal for replacement
- Cast iron rotor for greater durability and longer life
- Complete with 90° adjustable fittings for 3/8" hose
- Tilt mechanism for SilverSteer™ systems: **X83-SVS** - 44005J – Tilt range of 48° and five locking positions
- **KIT F** (optional): remote fill adapter

**WARNING:** UB-BB helm pumps are always to be installed in conjunction with the the UC128-SVS cylinder and the Kevlar reinforced hose kit KIT OB-SVS.

MODEL	P. No.	DISPLACEMENT/ REVOLUTION	No. OF PISTONS	RELIEF VALVE SETTING	MAXIMUM WHEEL DIA.	WEIGHT
UP25T-BB+X83-SVS	44196V + 44005J	25 cc - 1.7 cu.in	5	105 Bar - 1500 PSI	406 mm - 16"	5 kg - 11 lbs
UP28T-BB+X83-SVS	44197X + 44005J	28 cc - 2.0 cu.in	5	105 Bar - 1500 PSI	406 mm - 16"	5 kg - 11 lbs
UP33T-BB+X83SVS	44198Z + 44005J	33 cc - 2.4 cu.in	7	105 Bar - 1500 PSI	406 mm - 16"	5 kg - 11 lbs

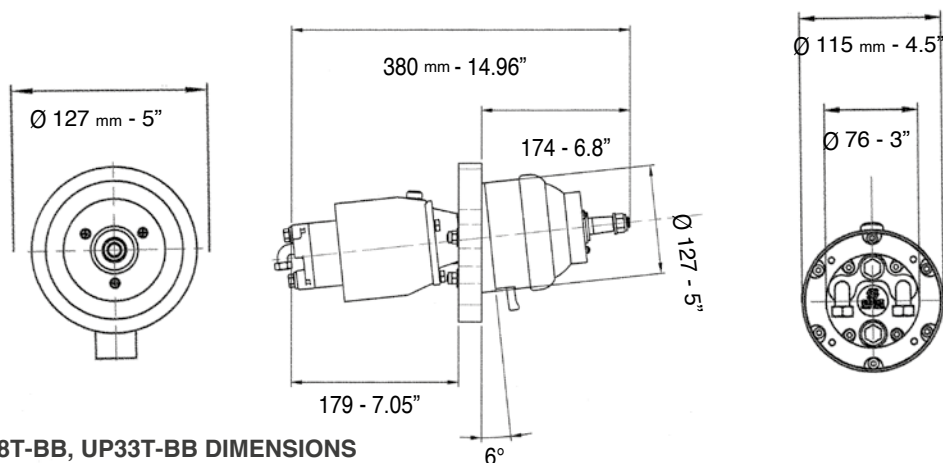

UP25T-BB, UP28T-BB, UP33T-BB DIMENSIONS

# UC128-SVS

## High Performance front mount cylinder



UC128-SVS/2

- UC128-SVS – Balanced: the number of wheel turns lock-to-lock is equal port to starboard or vice-versa
- Adjustable boss style fittings for easy installation
- High resistance stainless steel connection bolt (ULTRABOLT)
- Replaceable cylinder end caps

Specifically designed for high performance, high torque applications, the SilverSteer™ UC128 SVS cylinder is recommended for flat boats and tournament fishing boats.

- Compatible with competing helms, hoses and oil, the UC128-SVS cylinder is built with heavy duty stainless steel cylinder rod, seals and link assemblies, is simple to install and fits almost every 2 and 4 stroke outboard engine on the market.
- Depending on the applications on the outboard engines, the UC128-SVS is available in 2 versions - see the application guide to choose the appropriate cylinder (UC128-SVS/1, UC128-SVS/2) for your application.
- UC128-SVS cylinders are recommended for use with UP25, UP28, UP33 and UP39 series helms and preassembled hoses (Kit OB and Kit OB/R5).
- In the **applications with dual UC128-SVS cylinder** it is necessary to order a standard UC128-SVS cylinder (link arm attached to the starboard side of the cylinder) and a port UC128P-SVS cylinder (link arm attached to the port side of the cylinder). See tie bars section to select the required model for dual engine/dual cylinder applications. Depending on the applications on the outboard engines, the UC128P-SVS cylinder is available in 2 versions

**APPLICATION:** UC128-SVS front mount cylinder is not recommended for use in installations where the boat speed exceeds 69 mph (60 knots); 75 mph (65 knots) in dual engine, dual cylinder and counter rotating engines application). Not intended for use in racing applications.

Model	Part No.	Description	Volume
UC128-SVS/1	43870A	Front mount cylinder, starboard version	120 cc - 7.3 cu.in.
UC128-SVS/2	43872E	Front mount cylinder, starboard version	Output force
UC128P-SVS/1	41328U	Front mount cylinder, port version	450 kg (992 lbs)
UC128P-SVS/2	43873G	Front mount cylinder, port version	Internal diameter
			35 mm (1.37")
			Stroke
			185 mm (7.28")
			Fittings for high pressure flex hose
			3/8"
			Bleed fittings
			DN5 quick connect

**UC128-SVS**  
High performance front mount cylinder



UC128-SVS 1P

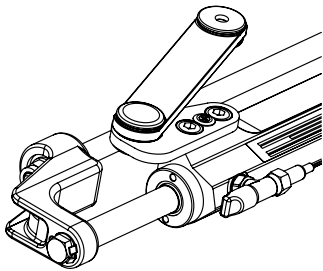

UC128-SVS/1

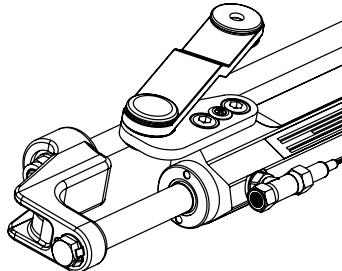

UC128-SVS/2

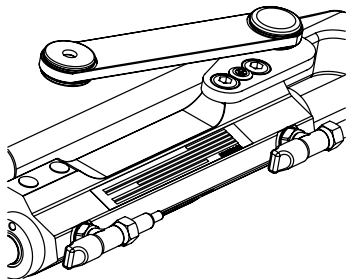

UC128-SVS 1P

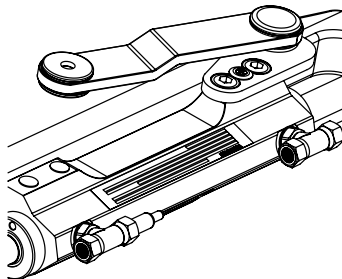

UC128-SVS 2P

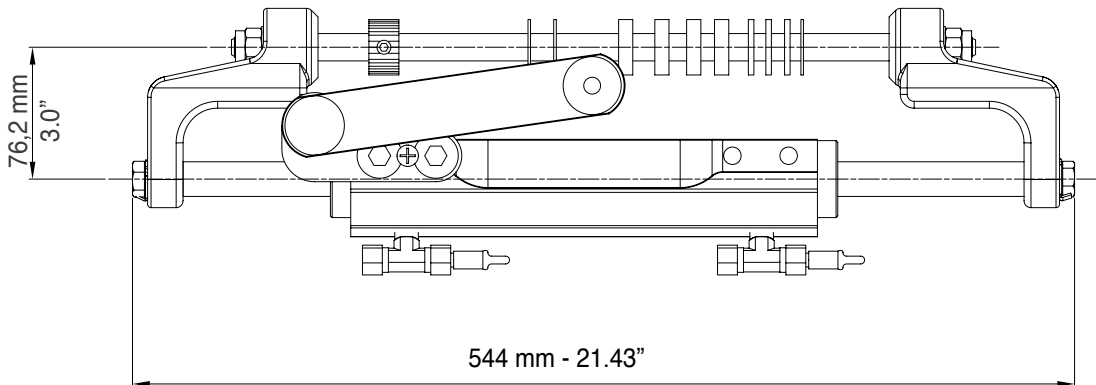

UC128-SVS, UC128 -SVS P DIMENSIONS



# UC128-SVS Cylinder Applications

UC128-SVS Applications				
ENGINE	MODEL	YEAR	CYLINDER	P. No.
Mercury® Mariner®	115-125-150 EFI 2S	1990-2007	UC128-SVS/1	43870A
	225-250 EFI 2S	2000-2007	UC128-SVS/1	43870A
	135-150-175 OPTIMAX	1999-2018	UC128-SVS/1	43870A
	200-225-250 OPTIMAX	1999-2018	UC128-SVS/1	43870A
	RACING 300 OPTIMAX	1999-2011	UC128-SVS/1	43870A
	250 SALTWATER EFI 4S	2007-2011	UC128-SVS/1	43870A
	135-150-175-200 VERADO L4	2004-2012	UC128-SVS/1	43870A
	FOURSTROKE 175-200 V6	2018-to date	UC128-SVS/1	43870A
	FOURSTROKE 225-300 V8	2018-to date	UC128-SVS/1	43870A
Evinrude®	E115-E130-E135 2S V4	1995-to date	UC128-SVS/2	43872E
	E150-E175-E200-E225-E250-E300 2S V6	1995-to date	UC128-SVS/2	43872E
Yamaha®	150F-200F-250G 2S	1990-2008	UC128-SVS/2	43872E
	150 HPDI VMAX 2S	1996-2007	UC128-SVS/2	43872E
	175-200-225-250-300 HPDI VMAX 2S	2000-2008	UC128-SVS/2	43872E
	F115-F150 EFI 4S	2000-2008	UC128-SVS/1	43870A
	F200-F225-F250 4S	1999-2007	UC128-SVS/2	43872E
	F115-F150-F175-F200 L4	2002-2007	UC128-SVS/1	43870A
	F200-F225-F250-F300 V6 4S	2004-to date	UC128-SVS/2	43872E
F350 4S V8	2006-to date	UC128-SVS/1	43870A	
Honda®	BF135-BF150 4S	2005-to date	UC128-SVS/1	43870A
	BF150 V-TEC 4S	2008-to date	UC128-SVS/1	43870A
	BF175-BF200-BF225- BF250 4S	2001-to date	UC128-SVS/1	43870A
Suzuki®	DF100-115-140 4S	2008-to date	UC128-SVS/1	43870A
	DF150-175-DF200 L4 4S	2006-to date	UC128-SVS/1	43870A
	DF200-DF225-DF250-DF300-DF350 V6 4S	2004-to date	UC128-SVS/2	43872E
Tohatsu®	115-120-140 2S	2004-to date	UC128-SVS/2	43872E
	70-90-115 TLDI 4S	2004-to date	UC128-SVS/1	43870A
	BFT 115-150-200-225-250 4S	2014-to date	UC128-SVS/1	43870A
	BFT60-75-90	2015-to date	UC128-SVS/1	43870A
Selva®	80 PORTOFINO/TIGERSHARK 2S	1995-2008	UC128-SVS/1	43870A
	150 WHITE SHARK 2S	2001-2007	UC128-SVS/2	43872E
	100EFI MARLIN -115 EFI NARWHAL	2000-to date	UC128-SVS/1	43870A
	225 BEAKED WHALE 4S	2019-to date	UC128-SVS/2	43872E
	150EFI KILLER WHALE 4S - 200 SEI WHALE 4S	2000-to date	UC128-SVS/1	43870A
Johnson®	BJ90-115-140 4S	2001-2007	UC128-SVS/1	43870A
	J90-115 V4 2S	1995-2007	UC128-SVS/2	43872E
	J150-175 V6 2S	1995-2007	UC128-SVS/2	43872E
	J200-225 V6 4S	2004-2007	UC128-SVS/2	43872E
OXE®	125-150-175-200HP DIESEL	2018-to date	UC128-SVS/1	43870A
	300 HP DIESEL	2020-to date	UC128-SVS/1	43870A
COX®	300 HP	2020-to date	UC128-SVS/2	43872E
NEANDER SHARK®	DTORQUE 111	2018-to date	UC128-SVS/1	43225U
Parsun®	F 300	2022-to date	UC128-SVS/2	43226W

## WARNING

These recommendations should be used as a general reference only. Final selection should be made with the assistance of a qualified installation technician.

For any further information please contact our Technical Service.



SYSTEM	APPLICATION	WHEEL TURNS	COMPONENTS	MODEL	Q.TY
<b>Single Engine Single Cylinder</b> 	Up to 350 hp max	4.8 (UP25)	Cylinder	UC128-SVS	1
			Helm pump	UP25 or UP33-SVS	1
			Hose Kit	KIT OB-SVS	1
		3.6 (UP33)	Oil	OIL 15	2
			Steering wheel	(Wheel selection)	1

For a second station add:  
1 UP25-SVS or UP33-SVS helm pump, 1 KIT OB-2S fitting kit, 1 KIT OB-SVS, 1 OIL 15, 1 steering wheel

### WARNING

The UC128-SVS front mount cylinder is not recommended for use in installations where the boat speed exceeds **69 mph (60 knots)**; (75 mph (65 knots) in dual engine, dual cylinder and counter rotating engines application). Not intended for use in racing applications.

<b>Dual engine Single cylinder</b> 	Up to 350 hp max (non-counter rotating engine)	4.8 (UP25)	Cylinder	UC128-SVS	1
			Helm pump	UP25 or UP33-SVS	1
			Hose Kit	KIT OB-SVS	1
		3.6 (UP33)	Oil	OIL 15	2
			Tie bar	A96	1
Steering wheel	(Wheel selection)	1			

For a second station add:  
1 UP25-SVS or UP33-SVS helm pump, 1 KIT OB-2S fitting kit, 1 KIT OB-SVS, 1 OIL 15, 1 steering wheel

<b>Dual engine Dual cylinder</b> 	Up to 600 hp max (non-counter rotating engines)	6,1 (UP39)	Cylinder	UC128-SVS	1
			Cylinder Port	UC128P-SVS	1
			Helm pump	UP39-SVS	1
			Hose Kit	KIT OB-SVS	1
			Oil	OIL 15	3
	Up to 700 hp max (counter rotating engines)		Tie bar	A95	1
			Steering wheel	(Wheel selection)	1
			Connection Kit	KIT OB-DBR-SVS	1

For a second station add:  
1 UP39-SVS helm pump, 1 KIT OB-2S fitting kit, 1 KIT OB-SVS, 2 T fittings 39502 V, 1 OIL 15, 1 steering wheel

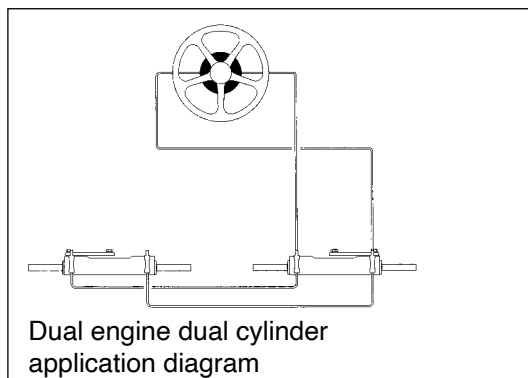

### ATTENTION:

The SilverSteer™ helm pumps are always to be installed in conjunction with the UC128-SVS cylinder and the Kevlar reinforced hose kit KIT OB-SVS.

**NOTE:** Three outboard engine applications are available with UC128-SVS cylinder. For triple outboard engine, dual cylinder applications, please refer to tie-bar section.

For any further and detailed information, please contact our Technical Service.

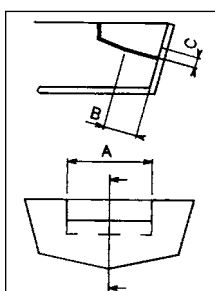

SPLASHWELL DIMENSION REQUIREMENTS			
Engine No.	A	B	C
1	560 mm - 22.05"	152 mm - 5.98"	152 mm - 5.98"
2	1110 mm - 43.70"	152 mm - 5.98"	152 mm - 5.98"

For twin engine applications minimum engine center distance is 550 mm (21.6")

# UC130-SVS

## High Performance front mount cylinder

Volume	130 cc - 7.3 cu. in.
Output force	740 kg (1631 lbs)
Internal diameter	36 mm (1.42")
Stroke	185 mm (7.28")
Fittings for high pressure flex hose	3/8" (9,5 mm)
Bleed fittings	DN5 quick connect



UC130-SVS – Balanced: the number of wheel turns lock-to-lock is equal port to starboard or vice-versa

- Side fittings for easy installation
- High resistance stainless steel connection bolt (ULTRABOLT)
- Replaceable cylinder end caps
- SilverSteer™ UC130-SVS cylinder is recommended for high horsepower applications, bass boats and tournament fishing boats.
- This cylinder is built with heavy duty stainless steel cylinder rod, seals and link assemblies, is simple to install and fits almost every 2 and 4 stroke outboard engine in the market. See the application guide to choose the appropriate cylinder (UC130-SVS/1 or UC130-SVS/2) for your application.

**APPLICATION:** UC130-SVS front mount cylinder is not recommended for use in installations where the boat speed exceeds 69 mph (60 knots); (75 mph (65 knots) in dual engine, dual cylinder and counter rotating engines application). Not intended for use in racing applications.

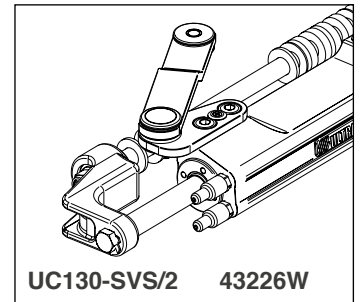
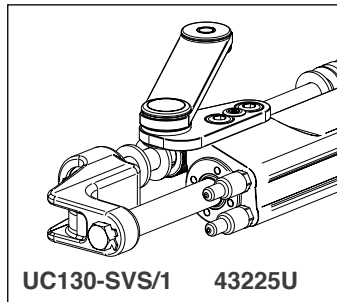

In the **applications with dual UC130-SVS cylinder** it is necessary to order a standard UC130-SVS cylinder (link arm attached to the starboard side of the cylinder) and a port UC130P-SVS cylinder (link arm attached to the port side of the cylinder). A95 tie bar is required for use on dual engine/dual cylinder applications.



UC130P-SVS

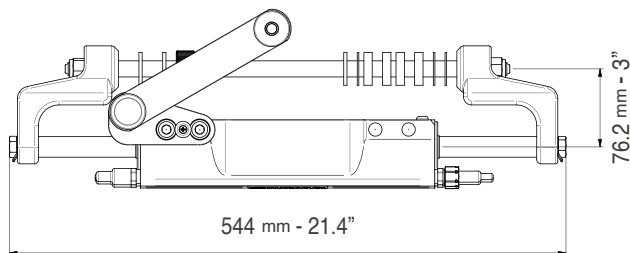
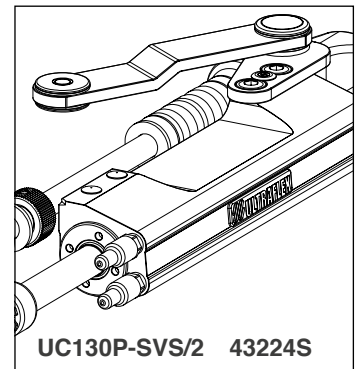
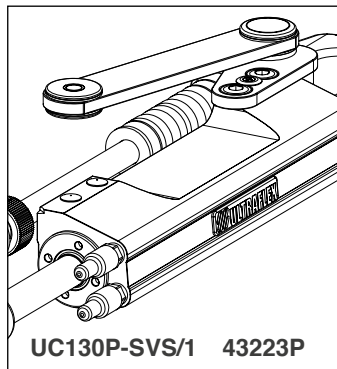

UC130-SVS, UC130P-SVS DIMENSIONS

Model	Part No.	Description
UC130-SVS/1	43225U	Front mount cylinder, starboard version
UC130-SVS/2	43226W	Front mount cylinder, starboard version
UC130-SVS/3	43227Y	Front mount cylinder, starboard version
UC130P-SVS/1	43223P	Front mount cylinder, port version
UC130P-SVS/2	43224S	Front mount cylinder, port version

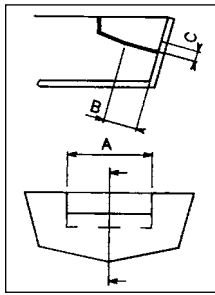

### SPLASHWELL DIMENSION REQUIREMENTS

Engine No.	A	B	C
1	560 mm - 22.05"	152 mm - 5.98"	152 mm - 5.98"
2	1110 mm - 43.70"	152 mm - 5.98"	152 mm - 5.98"

For twin engine applications minimum engine center distance is 650 mm (26")

### UC130-SVS Applications

ENGINE	MODEL	YEAR	CYLINDER	P. No.	PACKAGING
Mercury® Mariner®	115-125-150 EFI 2S	1990-2007	UC130-SVS/1	43225U	Silversteer 1
	225-250 EFI 2S	2000-2007	UC130-SVS/1	43225U	Silversteer 1
	135-150-175 OPTIMAX	1999-2018	UC130-SVS/1	43225U	Silversteer 1
	200-225-250 OPTIMAX	1999-2018	UC130-SVS/1	43225U	Silversteer 1
	RACING 300 OPTIMAX	1999-2011	UC130-SVS/1	43225U	Silversteer 1
	250 SALTWATER EFI 4S	2007-2011	UC130-SVS/1	43225U	Silversteer 1
	135-150-175-200 VERADO L4	2004-2012	UC130-SVS/1	43225U	Silversteer 1
	FOURSTROKE 175-200 V6 FOURSTROKE 225-300 V8	2018-to date 2018-to date	UC130-SVS/1 UC130-SVS/1	43225U 43225U	Silversteer 1 Silversteer 1
Evinrude®	E115-E130-E135 2S V4	1995-to date	UC130-SVS/2	43226W	Silversteer 2
	E150-E175-E200-E225-E250-E300 2S V6	1995-to date	UC130-SVS/2	43226W	Silversteer 2
Yamaha®	115C-130B 2S	1990-2008	UC130-SVS/2	43226W	Silversteer 2
	150F-200F-250G 2S	1990-2008	UC130-SVS/2	43226W	Silversteer 2
	150 HPDI VMAX 2S	1996-2007	UC130-SVS/2	43226W	Silversteer 2
	175-200-225-250-300 HPDI VMAX 2S	2000-2008	UC130-SVS/2	43226W	Silversteer 2
	F115-F150 EFI 4S	2000-2008	UC130-SVS/1	43225U	Silversteer 1
	F200-F225-F250 4S	1999-2007	UC130-SVS/2	43226W	Silversteer 2
	F115-F150-F175-F200 L4 F200-F225-F250-F300 V6 4S F350 4S V8	2002-to date 2004-to date 2006-to date	UC130-SVS/1 UC130-SVS/2 UC130-SVS/1	43225U 43226W 43225U	Silversteer 1 Silversteer 2 Silversteer 1
Honda®	BF135-BF150 4S	2005-to date	UC130-SVS/1	43225U	Silversteer 1
	BF150 V-TEC 4S	2008-to date	UC130-SVS/1	43225U	Silversteer 1
	BF175-BF200-BF225- BF250 4S	2001-to date	UC130-SVS/1	43225U	Silversteer 1
Suzuki®	DF100-115-140 4S	2008-to date	UC130-SVS/1	43225U	Silversteer 1
	DF150-175-DF200 L4 4S	2006-to date	UC130-SVS/1	43225U	Silversteer 1
	DF200-DF225-DF250-DF300-DF350 V6 4S	2004-to date	UC130-SVS/2	43226W	Silversteer 2
Tohatsu®	115-120-140 2S	2004-to date	UC130-SVS/2	43226W	Silversteer 2
	70-90-115 TLDI 4S	2004-to date	UC130-SVS/1	43225U	Silversteer 1
	MFS 50-60-75-90-100-115 4S	2018-to date	UC130-SVS/1	43225U	Silversteer 1
	BFT 115-150-200-225-250 4S	2014-to date	UC130-SVS/1	43225U	Silversteer 1
	BFT60-75-90-100 4S	2015-to date	UC130-SVS/1	43225U	Silversteer 1
Selva®	80 PORTOFINO/TIGERSHARK 2S	1995-2008	UC130-SVS/1	43225U	Silversteer 1
	150 WHITE SHARK 2S	2001-2007	UC130-SVS/2	43226W	Silversteer 2
	100EFI MARLIN -115 EFI NARWHAL	2000-to date	UC130-SVS/1	43225U	Silversteer 1
	225 BEAKED WHALE 4S	2019-to date	UC130-SVS/2	43226W	Silversteer 2
	150EFI KILLER WHALE 4S - 200 SEI WHALE 4S	2000-to date	UC130-SVS/1	43225U	Silversteer 1
Johnson®	BJ90-115-140 4S	2001-2007	UC130-SVS/1	43225U	Silversteer 1
	J90-115 V4 2S	1995-2007	UC130-SVS/2	43226W	Silversteer 2
	J150-175 V6 2S	1995-2007	UC130-SVS/2	43226W	Silversteer 2
	J200-225 V6 4S	2004-2007	UC130-SVS/2	43226W	Silversteer 2
OXE®	125-150-175-200HP DIESEL	2018-to date	UC130-SVS/1	43225U	Silversteer 1
	300 HP DIESEL	2020-to date	UC130-SVS/1	43225U	Silversteer 1
COX®	300 HP	2020-to date	UC130-SVS/2	43226W	Silversteer 2
NEANDER SHARK®	DTORQUE 111	2018-to date	UC130-SVS/1	43225U	Silversteer 1
Parsun®	F 300	2022-to date	UC130-SVS/2	43226W	Silversteer 2



### WARNING

These recommendations should be used as a general reference only. Final selection should be made with the assistance of a qualified installation technician. For any further information please contact our Technical Service.



# UC130-SVS Order Guide



SYSTEM	APPLICATION	WHEEL TURNS	COMPONENTS	MODEL	Q.TY
<b>Single Engine Single Cylinder</b> 	Up to 350 hp max	5.5 (UP25)	Cylinder Helm pump Hose Kit	UC130-SVS UP25 or UP33-SVS	1 1 1
		3.9 (UP33)	Oil Steering wheel	KIT OB-SVS OIL 15 (Wheel selection)	2 1
For a second station add: 1 UP25-SVS or UP33-SVS helm pump, 1 KIT OB-2S fitting kit, 1 KIT OB-SVS, 1 OIL 15, 1 steering wheel					
<b>Dual engine Single cylinder</b> 	Up to 350 hp max (non-counter rotating engine)  Up to 600 hp max (counter rotating engine)	5.5 (UP25)	Cylinder Helm pump Hose Kit	UC130-SVS UP25 or UP33-SVS	1 1 1
		3.9 (UP33)	Oil Tie bar Steering wheel	KIT OB-SVS OIL 15 A96 (Wheel selection)	2 1 1
For a second station add: 1 UP25-SVS or UP33-SVS helm pump, 1 KIT OB-2S fitting kit, 1 KIT OB-SVS, 1 OIL 15, 1 steering wheel					
<b>Dual engine Dual cylinder</b> 	Up to 600 hp max (non-counter rotating engines)  Up to 700 hp max (counter rotating engines)	6,6 (UP39)	Cylinder Cylinder Port Helm pump Hose Kit	UC130-SVS UC130P-SVS UP39-SVS	1 1 1
			Oil Tie bar Steering wheel Connection Kit	KIT OB-SVS OIL 15 A95 (Wheel selection) KIT OB-DBR130-SVS	1 3 1 1 1
For a second station add: 1 UP39-SVS helm pump, 1 KIT OB-2S fitting kit, 1 KIT OB-SVS, 2 T fittings 39502 V, 1 OIL 15, 1 steering wheel					

### WARNING

The UC130-SVS front mount cylinder is not recommended for use in installations where the boat speed exceeds **69 mph (60 knots)**; (75 mph (65 knots) in dual engine, dual cylinder and counter rotating engines application). Not intended for use in racing applications.

**NOTE:** Three outboard engine applications are available with UC130-SVS cylinder.

**For triple outboard engine, dual cylinder applications, please refer to tie-bar section.**

For any further and detailed information, please contact our Technical Service.

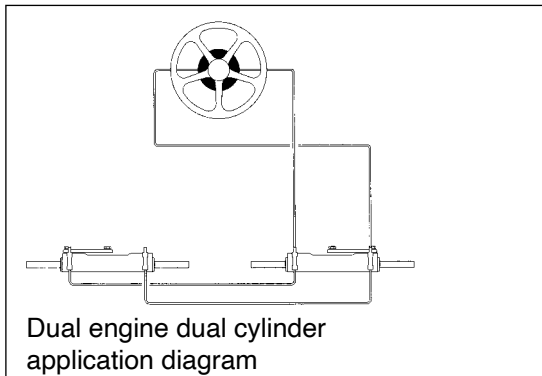

### ATTENTION:

The SilverSteer™ helm pumps are always to be installed in conjunction with the UC130-SVS cylinder and the Kevlar reinforced hose kit KIT OB-SVS.

### SILVERSTEER wheel turns 5.5

SilverSteer package kit contains:

- UP25F-SVS** Front mount helm pump
- UC130-SVS** Front mount outboard cylinder.  
Specify engine type when ordering.
- Silversteer 1 -** with UC130-SVS/1 cylinder
- Silversteer 2 -** with UC130-SVS/2 cylinder
- OIL 15** Hydraulic oil 2 litres (0.5 gallons).
- KIT OB-SVS** Hose kit with preassembled fittings.  
Specify length required when ordering.



# UC128-BB

## High Performance front mount cylinder



**new**



**UC128-BB**

- UC128-BB – Balanced: the number of wheel turns lock-to-lock is equal port to starboard or vice-versa
- Adjustable boss style fittings for easy installation
- High resistance stainless steel connection bolt (ULTRABOLT)
- Replaceable cylinder end caps

Specially designed for high performance, high torque applications UC128- BB cylinder is recommended for bass boats.

- Compatible with competing helms, hoses and oil, the UC128-BB cylinder is built with heavy duty stainless steel cylinder rod, seals and link assemblies, is simple to install and fits almost every 2 and 4 stroke outboard engine on the market.
- Depending on the applications on the bass boats, the UC128-BB is available in 2 versions - see the application guide to choose the appropriate cylinder (UC128-BB/1, UC128-BB/2) for your application.
- UC128-BB cylinders are recommended for use with UP25BB, UP28BB and UP33BB series helms and preassembled hoses (Kit OB and Kit OB/R5).

**APPLICATION:** UC128-BB front mount cylinder is not recommended for use in installations where the boat speed exceeds 100 mph (87 knots); .

Not intended for use in racing applications.

Model	Part No.	Description
UC128-BB/1	44193N	Front mount cylinder, starboard version
UC128-BB/2	44194R	Front mount cylinder, starboard version

Volume	120 cc - 7.3 cu.in.
Output force	450 kg (992 lbs)
Internal diameter	35 mm (1.37")
Stroke	185 mm (7.28")
Fittings for high pressure flex hose	3/8"
Bleed fittings	DN5 quick connect



# UC128-BB

High performance front mount cylinder

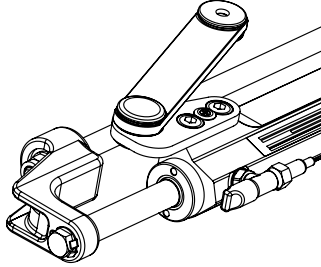

UC128-SVS/1

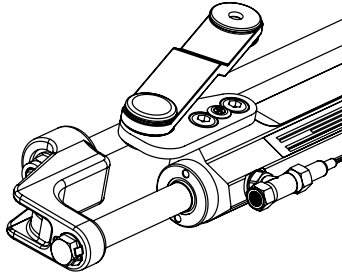

UC128-SVS/2

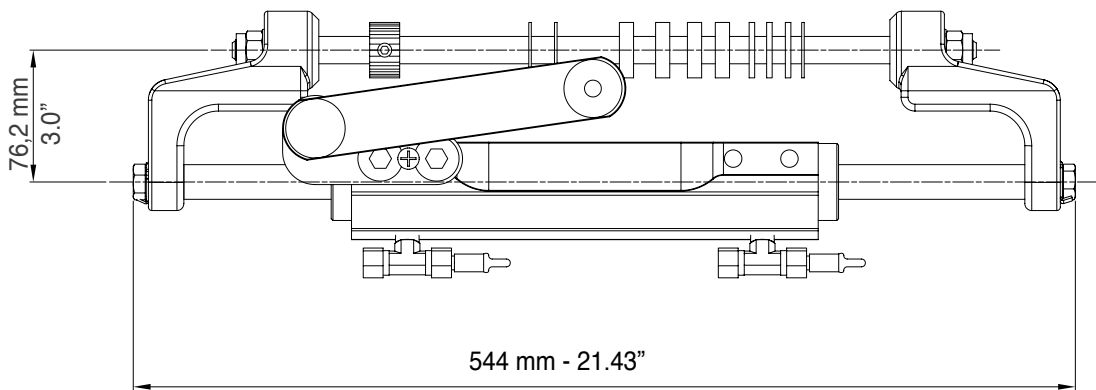

UC128-SVS, UC128P-SVS DIMENSIONS

# UC128-BB Cylinder Applications

UC128-BB Applications				
ENGINE	MODEL	YEAR	CYLINDER	P. No.
Mercury® Mariner®	115-125-150 EFI 2S	1990-2007	UC128-BB/1	44193N
	225-250 EFI 2S	2000-2007	UC128-BB/1	44193N
	135-150-175 OPTIMAX	1999-2018	UC128-BB/1	44193N
	200-225-250 OPTIMAX	1999-2018	UC128-BB/1	44193N
	RACING 300 OPTIMAX	1999-2011	UC128-BB/1	44193N
	250 SALTWATER EFI 4S	2007-2011	UC128-BB/1	44193N
	135-150-175-200 VERADO L4	2004-2012	UC128-BB/1	44193N
	FOURSTROKE 175-200 V6	2018-to date	UC128-BB/1	44193N
	FOURSTROKE 225-300 V8	2018-to date	UC128-BB/1	44193N
Evinrude®	E115-E130-E135 2S V4	1995-to date	UC128-BB/2	44194R
	E150-E175-E200-E225-E250-E300 2S V6	1995-to date	UC128-BB/2	44194R
Yamaha®	150F-200F-250G 2S	1990-2008	UC128-BB/2	44194R
	150 HPDI VMAX 2S	1996-2007	UC128-BB/2	44194R
	175-200-225-250-300 HPDI VMAX 2S	2000-2008	UC128-BB/2	44194R
	F115-F150 EFI 4S	2000-2008	UC128-BB/1	44193N
	F200-F225-F250 4S	1999-2007	UC128-BB/2	44194R
	F115-F150-F175-F200 L4	2002-2007	UC128-BB/1	44193N
	F200-F225-F250-F300 V6 4S	2004-to date	UC128-BB/2	44194R
	F350 4S V8	2006-to date	UC128-BB/1	44193N
Honda®	BF135-BF150 4S	2005-to date	UC128-BB/1	44193N
	BF150 V-TEC 4S	2008-to date	UC128-BB/1	44193N
	BF175-BF200-BF225- BF250 4S	2001-to date	UC128-BB/1	44193N
Suzuki®	DF100-115-140 4S	2008-to date	UC128-BB/1	44193N
	DF150-175-DF200 L4 4S	2006-to date	UC128-BB/1	44193N
	DF200-DF225-DF250-DF300-DF350 V6 4S	2004-to date	UC128-BB/2	44194R
Tohatsu®	115-120-140 2S	2004-to date	UC128-BB/2	44194R
	70-90-115 TLDI 4S	2004-to date	UC128-BB/1	44193N
	BFT 115-150-200-225-250 4S	2014-to date	UC128-BB/1	44193N
	BFT60-75-90	2015-to date	UC128-BB/1	44193N
Selva®	80 PORTOFINO/TIGERSHARK 2S	1995-2008	UC128-BB/1	44193N
	150 WHITE SHARK 2S	2001-2007	UC128-BB/2	44194R
	100EFI MARLIN -115 EFI NARWHAL	2000-to date	UC128-BB/1	44193N
	225 BEAKED WHALE 4S	2019-to date	UC128-BB/2	44194R
	150EFI KILLER WHALE 4S - 200 SEI WHALE 4S	2000-to date	UC128-BB/1	44193N
Johnson®	BJ90-115-140 4S	2001-2007	UC128-BB/1	44193N
	J90-115 V4 2S	1995-2007	UC128-BB/2	44194R
	J150-175 V6 2S	1995-2007	UC128-BB/2	44194R
	J200-225 V6 4S	2004-2007	UC128-BB/2	44194R
OXE®	125-150-175-200HP DIESEL	2018-to date	UC128-BB/1	44193N
	300 HP DIESEL	2020-to date	UC128-BB/1	44193N
COX®	300 HP	2020-to date	UC128-BB/2	44194R
NEANDER SHARK®	DTORQUE 111	2018-to date	UC128-BB/1	44193N
Parsun®	F 300	2022-to date	UC128-BB/2	44194R

# UC128-BB Order Guide

SYSTEM	APPLICATION	WHEEL TURNS	COMPONENTS	MODEL	Q.TY
<b>Single Engine Single Cylinder</b> 	Up to 350 hp max	4.8 (UP25)	Cylinder	UC128-BB	1
			Helm pump	UP25 BB, UP28 BB	1
			Hose Kit	or UP33 BB	1
			Oil	KIT OB-SVS	2
			3.6 (UP33)	Steering wheel	OIL 15 (Wheel selection)

### WARNING

The UC128-BB front mount cylinder is not recommended for use in installations where the boat speed exceeds **100 mph (87knots)**. Not intended for use in racing applications.

### ATTENTION:

Bass Boat helm pumps are always to be installed in conjunction with the UC128-BB cylinder and the Kevlar reinforced hose kit KIT OB-SVS.

**NOTE:** For any further and detailed information, please contact our Technical Service.

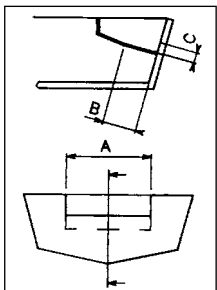

SPLASHWELL DIMENSION REQUIREMENTS			
Engine No.	A	B	C
1	560 mm - 22.05"	152 mm - 5.98"	152 mm - 5.98"

## KIT OB-SVS AND KIT OB-BHBR-SVS: HOSE KITS FOR SINGLE STATION INSTALLATION FOR SILVERSTEER SYSTEMS

Two high pressure Kevlar stranded hoses with pre-cripped nickel plated brass fittings, bulkhead fittings (for KIT OB-BHBR-SVS only) and bend restrictors on one end. Recommended for use with all Uflex SilverSteer and MasterDrive helms with 1500 psi relief valves.

KIT OB-SVS	KIT OB-BHBR-SVS	LENGTH
KIT OB-SVS-06	KIT OB-BHBR-SVS-06	6'
KIT OB-SVS-08	KIT OB-BHBR-SVS-08	8'
KIT OB-SVS-10	KIT OB-BHBR-SVS-10	10'
KIT OB-SVS-12	KIT OB-BHBR-SVS-12	12'
KIT OB-SVS-14	KIT OB-BHBR-SVS-14	14'
KIT OB-SVS-16	KIT OB-BHBR-SVS-16	16'
KIT OB-SVS-18	KIT OB-BHBR-SVS-18	18'
KIT OB-SVS-20	KIT OB-BHBR-SVS-20	20'
KIT OB-SVS-22	KIT OB-BHBR-SVS-22	22'
KIT OB-SVS-24	KIT OB-BHBR-SVS-24	24'
KIT OB-SVS-26	KIT OB-BHBR-SVS-26	26'
KIT OB-SVS-28	KIT OB-BHBR-SVS-28	28'
KIT OB-SVS-30	KIT OB-BHBR-SVS-30	30'



KIT OB-SVS



KIT OB-BHBR-SVS

## KITS FOR A SECOND STEERING STATION OR AUTOPILOT INSTALLATION

### KIT OB-2S - 39539V

It includes all necessary fittings and 7,6 m (25 ft) of 3/8" dia. nylon tube for the compensating line

### KIT 95-2S - 43184G:

It includes:

- (1) 40800L - Non Vented Cap
- (2) CONNECTOR FITT. - 1/4npt to 3/8 straight fitting
- (2) UNION T - 3/8" Tube Brass T Fitting



KIT 95-2S



KIT OB-2S

## KIT OB-DBR130-SVS: DUAL CYLINDER/DUAL ENGINE CONNECTION KIT FOR UC130-SVS

Two high pressure Kevlar stranded flexible hoses with pre-cripped fittings. **Recommended only for use with UC130-SVS.**

**NOTE:** For UC128-SVS applications (previous SilverSteer cylinder model), please contact our Technical Service

KIT OB-DBR130-SVS	ENGINE CENTERS	HOSE LENGTH
KIT OB-DBR130-SVS-15	26"	15"
KIT OB-DBR130-SVS-16	27"	16"
KIT OB-DBR130-SVS-17	28"	17"
KIT OB-DBR130-SVS-17.5	28.5"	17.5"
KIT OB-DBR130-SVS-18	29"	18"
KIT OB-DBR130-SVS-19	30"	19"
KIT OB-DBR130-SVS-19.5	30.5"	19.5"
KIT OB-DBR130-SVS-20	31"	20"
KIT OB-DBR130-SVS-21	32"	21"



KIT OB-DBR130-SVS

## A94 Tie bars

for twin outboard engine/single UC128-OBF or UC128-SVS or UC130-SVS cylinder

- Suitable for applications with single UC128-OBF or UC130-SVS front mount cylinder  
NOTE: In the applications with dual cylinder use A90 tie bar for UC128-OBF and A95 tie bar for UC130-SVS
- Allows to tilt the engines independently
- Stainless steel components
- Electropolished stainless steel ball joints
- Not recommended for applications exceeding 500 HP
- 5 different lengths available:  
A94 x 26 – 42448 K - 26" (660,4 mm) twin engine centers  
A94 x 28 – 42449 M - 28" (711,2 mm) twin engine centers  
**A94 x 30** – 42450 W - 30" (762,0 mm) twin engine centers  
**A94 x 32** – 42451 Y - 32" (812,8 mm) twin engine centers  
**A94 x 34** – 42452 A - 34" (863,6 mm) twin engine centers

**A94** – 41204 Z - adjustable from 26" to 37.4" (660 mm to 950 mm) engine centers

ATTENTION: As the tiller arm position varies from engine to engine and the distance between two engines is not predictable, unexpected interferences may occur while tilting. A duly check of the tie bar installation is then strongly recommended.  
Should you need additional information, please do not hesitate to refer to our Technical Service.



A94 x 26



A94 - 41204 Z

### A94 TIE BAR APPLICATIONS

#### WARNING

These recommendations should be used as a general reference only. For any further information please contact our Technical Service.

ENGINE	Power
Mercury®	135-150-175 Optimax 2T 200-225 Optimax 2T 250 PRO XS 135-150-175 Verado 4T 200 Verado 4T
Yamaha®	F115-150-200-225-250 4T
Suzuki®	DF70-80-90 4T DF100-115-140-150-175 4T DF200-250-300 DOHC 4T
Honda®	115-135-150 OHC BF 200 SOHC BF 225 A6
Evinrude®	E115-130-150-175-200 V6 E200-225-250-300

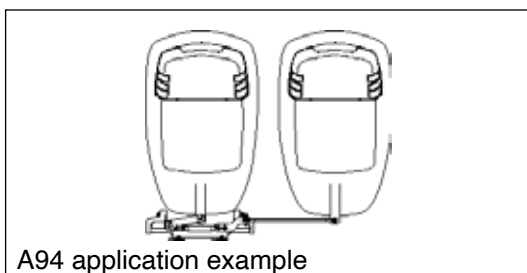

A94 application example



UC128 + A94

# A96 Tie bars for twin outboard engine/single UC128-OBF or UC128-SVS or UC130-SVS cylinder



- 2 available different lengths:  
From 26" to 29" engine center  
From 29" to 34.5" engine center

- Suitable for applications with single UC128-OBF or UC130-SVS front mount cylinder
- Allows to tilt the engines independently
- Stainless steel components
- Electropolished stainless steel ball joints
- Also available in semi-assembled bars and brackets

<b>A96 M/Y-29</b>	43496C	From 26" to 29" engine center - Mercury® and Yamaha® engines
<b>A96 M/Y-34.5</b>	43497E	From 29" to 34.5" engine center - Mercury® and Yamaha® engines
<b>A96 S/H-29</b>	43897X	From 26" to 29" engine center - Suzuki® and Honda® engines
<b>A96 S/H-34.5</b>	43898Z	From 29" to 34.5" engine center - Suzuki® and Honda® engines



**UC128 + A96**

**WARNING:** These recommendations should be used as a general reference only. These recommendations should be used as a general reference only. As the tiller arm position varies from engine to engine and the distance between two engines is not predictable, unexpected interferences may occur while tilting. A duly check of the tie bar installation is then strongly recommended. Should you need additional information, please do not hesitate to refer to our Technical Service.

## A96 TIE BAR APPLICATIONS

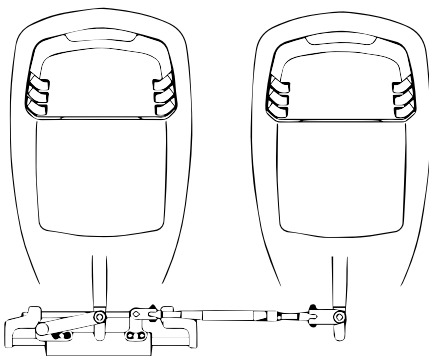

**A96 application example**

ENGINE	Power
Mercury®	135-150-175 Optimax 2T
	200-225 Optimax 2T
	250 PRO XS
	135-150-175 Verado 4T
	200 Verado 4T
Yamaha®	F115-150-200-225-250 4T
Suzuki®	DF70-80-90 4T
	DF100-115-140-150-175 4T
	DF200-250-300 DOHC 4T
Honda®	115-135-150 OHC BF
	200 SOHC BF
	225 A6

**NOTE:** Suzuki® engines DF100-115-140 4S require A90 - 40138H tie bar



## A95 Tie bars for twin outboard engine/dual UC128-OBF or UC128-SVS or UC130-SVS cylinder



A95 M/Y-32



A95 S/H-32

- Suitable for applications with dual UC128-OBF or UC130-SVS front mount cylinder with the exception of the dual UC128-OBF cylinder with Suzuki DF100-115-140 4S engines. For these applications **A90** - 40138H tie bar is used.
- Allows to tilt the engines independently
- All stainless steel components
- Electropolished stainless steel ball joints
- Also available in semi-assembled bars and brackets

- 2 available different lengths:  
From 26" to 32" engine center  
From 32" to 37.5" engine center

<b>A95 M/Y-32</b>	43409E	From 26" to 32" engine center - Mercury® and Yamaha® engines
<b>A95 M/Y-37.5</b>	43410N	From 32" to 37.5" engine center - Mercury® and Yamaha® engines
<b>A95 S/H-32</b>	43901J	From 26" to 32" engine center - Suzuki® and Honda® engines
<b>A95 S/H-37.5</b>	43902L	From 32" to 37.5" engine center - Suzuki® and Honda® engines

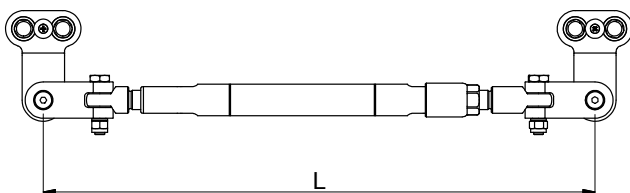

### ENGINE CENTER DISTANCE:

660 mm (26")	L= 455 mm (18")
813 mm (32")	L= 608 mm (24")
952 mm (37.5")	L= 747 mm (29.5")

# A95 Tie bars for twin outboard engine/dual UC128-OBF or UC128-SVS or UC130-SVS cylinder



UC128 + A95

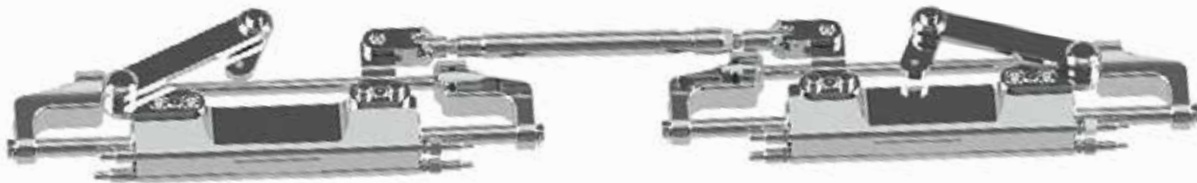

UC130 + A95

**WARNING:** In the applications with dual UC128-OBF or UC130-SVS cylinder it is necessary to order a standard UC128-OBF or UC130-SVS cylinder (link arm attached to the starboard side of the cylinder) and a UC128P-OBF or UC130P-SVS port cylinder (link arm attached to the port side of the cylinder).

UC128 starboard cylinders:

**UC128-OBF/1** - 43231N

**UC128-OBF/2** - 43232R

**UC128-OBF/3** - 43233T

UC128P port cylinders:

**UC128P-OBF/1** - 43234V

**UC128P-OBF/2** - 43235X

UC130 starboard cylinders:

**UC130-SVS/1** - 43225U

**UC130-SVS/2** - 43226W

**UC130-SVS/3** - 43227Y

UC130P port cylinders:

**UC130P-SVS/1** - 43223P

**UC130P-SVS/2** - 43224S

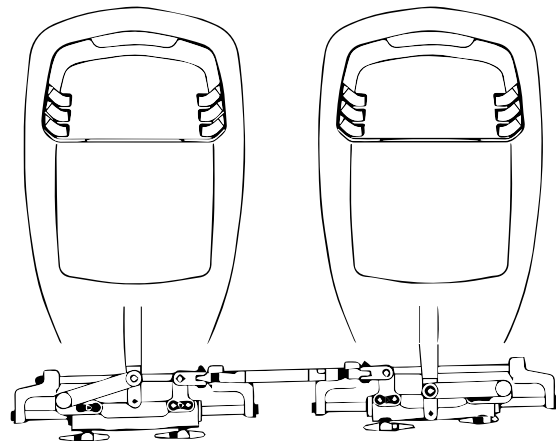

A95 - application example

**WARNING:** As the tiller arm position varies from engine to engine and the distance between two engines is not predictable, unexpected interferences may occur while tilting.

Checking the cowling clearances with the tie bar at various engine tilt positions and turning angles is required.

Should you need additional information, please do not hesitate to refer to our Technical Service.

## A90 Tie bar

Suzuki® DF100-115-140 4S twin outboard engine/twin UC128-OBF cylinder

A90 - 40138H



- Suitable for applications with dual UC128-OBF front mount cylinder
- All stainless steel components
- Electropolished stainless steel ball joints
- Allows to tilt the engines independently
- Applicable to engine centers variable from 660 mm (26") to 950 mm (37.4").



UC128 + A90

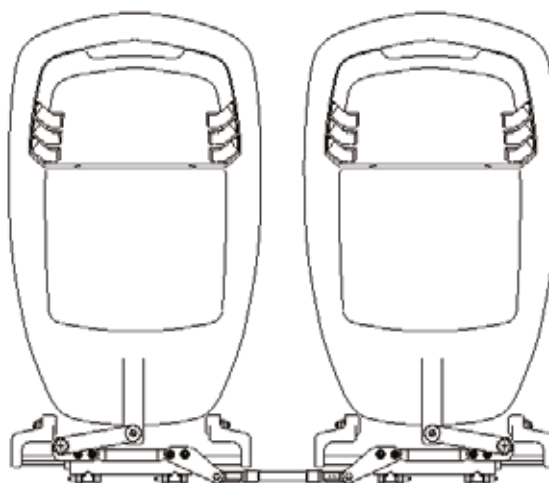

A90 - application example



A90

## AS-GEN3 - 43918C - Tie bar for Suzuki GEN3 engines



Suitable for applications with Suzuki GEN3 engines with integrated cylinder and Silversteer, Masterdrive, Integra systems

# A97 - Tie bars for triple outboard engine/dual UC128OBF or UC128-SVS or UC130-SVS cylinder



Suitable for applications with triple outboard engines and dual cylinder UC128-OBF or UC128-SVS or UC130-SVS  
 • Also available in semi-assembled bars and brackets

- 2 available different lengths:
- From 26" to 30" engine center
- From 30" to 35.5" engine center

<b>A97 M/Y-30</b>	43513Z	From 26" to 30" engine center Mercury® and Yamaha® engines Mercury® bracket included
<b>A97 M/Y-35.5</b>	43514B	From 30" to 35.5" engine center Mercury® and Yamaha® engines Mercury® bracket included
<b>A97 S/H-30</b>	43905T	From 26" to 30" engine center Suzuki® and Honda® engines
<b>A97 S/H-35.5</b>	43906V	From 30" to 35.5" engine center Suzuki® and Honda® engines



**MERCURY® BRACKET KIT - 43911M**

Heavy duty triple engine/twin cylinder tie bar kit for use with UC128-OBF or UC128-SVS or UC130-SVS and UC128P-OBF or UC128P-SVS or UC130P-SVS "Port" version outboard cylinders. These AISI 304 electropolished and passivated stainless steel tie bars are easy to install and allow for independent engine trimming with minimal effect on alignment.

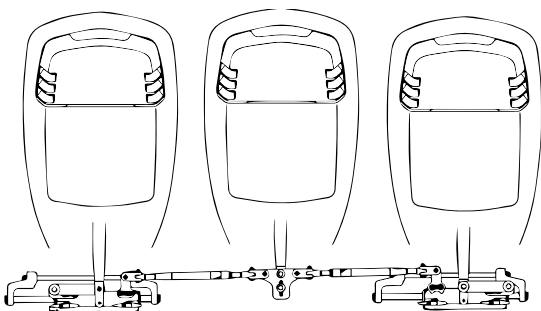

**A97 - application example**

ENGINE	POWER
Mercury®	175/200/225 V6 Fourstroke 250/275/300 V8 Fourstroke OPTIMAX V6
Yamaha®	200/225/250/300 V6 150/175/200 L4
Suzuki®	200/225/250/300/350 V6/V8 150/175/200 L4
Honda®	200/225/250 V6

## A98 - Tie bars

for quad outboard engine/dual UC128OBF or UC128-SVS or UC130-SVS cylinder



A98 M/Y



A98 S/H



UC128 + A98

Suitable for applications with quad outboard engine and dual cylinder UC128-OBF or UC128-SVS or UC130-SVS  
 • Also available in semi-assembled bars and brackets  
 From 26" to 32" engine center

<b>A98 M/Y</b>	43542G	From 26" to 32" engine center - Mercury® and Yamaha® engines
<b>A98 S/H</b>	43909B	From 26" to 32" engine center - Suzuki® and Honda® engines

Heavy duty quad engine/twin cylinder tie bar kit for use with UC128-OBF or UC130-SVS and UC128P-OBF or UC130P-SVS "Port" version outboard cylinders. These AISI 304 electropolished and passivated stainless steel tie bars are easy to install and allow for independent engine trimming with minimal effect on alignment.

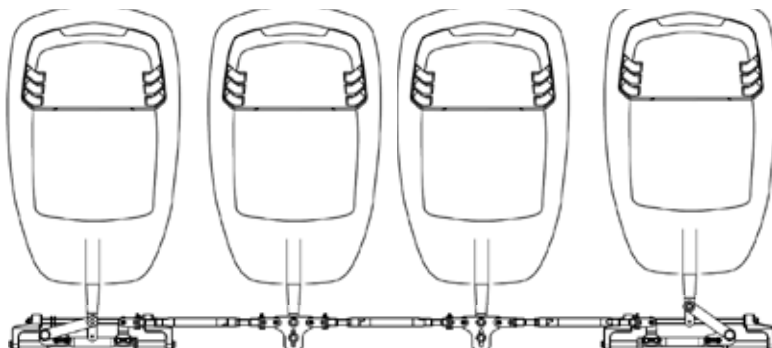

A98 - application example

ENGINE	POWER
Mercury®	175/200/225 V6 Fourstroke 250/275/300 V8 Fourstroke OPTIMAX V6
Yamaha®	200/225/250/300 V6 150/175/200 L4
Suzuki®	200/225/250/300/350 V6/V8 150/175/200 L4
Honda®	200/225/250 V6



MERCURY® BRACKET KIT - 43911M

## Tie bars - Connecting bar assemblies without brackets

### CONNECTING BAR ASSEMBLY - 43913C

Connecting bar assembly compatible with:

A96 M/Y-29

A95 M/Y-32

A96 S/H-29

A95 S/H-32



Bars include engine side bracket connectors.

### CONNECTING BAR ASSEMBLY - 43919E

Connecting bar assembly compatible with:

A96 M/Y-34.5

A95 M/Y-37.5

A97 M/Y-35.5

A96 S/H-34.5

A95 S/H-37.5

A97 S/H-35.5



Bars include engine side bracket connectors.

### CONNECTING BAR ASSEMBLY - 43921R

Connecting bar assembly compatible with:

A97 M/Y-30

A98 M/Y (external tie bar)

A97 S/H-30

A98 S/H (external tie bar)



Bars include engine side bracket connectors.

### CONNECTING BAR ASSEMBLY - 43920N

Connecting bar assembly compatible with:

A98 M/Y (central tie bar)

A98 S/H (central tie bar)



Bars include engine side bracket connectors.



## Brackets for Tie Bars

### CYLINDER SIDE BRACKET FOR TIE BARS - MERCURY® AND YAMAHA® ENGINES - 43912P

Cylinder side bracket compatible with:

A96 M/Y-29

A95 M/Y-32

A97 M/Y-30

A98 M/Y

A96 M/Y-34.5

A95 M/Y-37.5

A97 M/Y-35.5



### CYLINDER SIDE BRACKET FOR TIE BARS - SUZUKI® AND HONDA® ENGINES - 43988A

Cylinder side bracket compatible with:

A96 S/H-29

A95 S/H-32

A97 S/H-30

A98 S/H

A96 S/H-34.5

A95 S/H-37.5

A97 S/H-35.5



### ENGINE SIDE BRACKET FOR A96 M/Y TIE BARS - MERCURY® AND YAMAHA® ENGINES - 43916Y

Engine side bracket compatible with:

A96 M/Y-29

A96 M/Y-34.5



It is necessary to remove the engine side connector from the connecting bar assembly and add the bracket 43916Y.

### ENGINE SIDE BRACKET FOR TIE BARS - MERCURY® AND YAMAHA® (with the exception of A96 M/Y), SUZUKI® AND HONDA® ENGINES - 43917A

Engine side bracket compatible with:

A96 S/H-29

A97 M/Y-30

A98 M/Y

A96 S/H-34.5

A97 M/Y-35.5

A98 S/H

A97 S/H-30

A97 S/H-35.5



### MERCURY® BRACKET KIT - 43911M

Mercury® bracket kit compatible with:

A97 M/Y-30

A98 M/Y

A97 M/Y-35.5



## Tie Bars components selection chart

Tie bar model	suitable for engines	Tie bar part no.	External connecting bar assembly		Central connecting bar assembly		Cylinder side bracket		Engine or central side bracket		Mercury® bracket kit	
			part no.	Qt	part no.	Qt	part no.	Qt	part no.	Qt	part no.	Qt
A96 M/Y-29	Mercury® / Yamaha®	43496C	43913C	1	-	-	43912P	1	43916Y	1	-	-
A96 M/Y-34.5	Mercury® / Yamaha®	43497E	43919E	1	-	-	43912P	1	43916Y	1	-	-
A95 M/Y-32	Mercury® / Yamaha®	43409E	43913C	1	-	-	43912P	2	-	-	-	-
A95 M/Y-37.5	Mercury® / Yamaha®	43410N	43919E	1	-	-	43912P	2	-	-	-	-
A97 M/Y-30	Mercury® / Yamaha®	43513Z	43921R	2	-	-	43912P	2	43917A	1	43911M	1
A97 M/Y-35.5	Mercury® / Yamaha®	43514B	43919E	2	-	-	43912P	2	43917A	1	43911M	1
A98 M/Y	Mercury® / Yamaha®	43542G	43921R	2	43920N	1	43912P	2	43917A	2	43911M	2
A96 S/H-29	Suzuki® / Honda®	43897X	43913C	1	-	-	43988A	1	43917A	1	-	-
A96 S/H-34.5	Suzuki® / Honda®	43898Z	43919E	1	-	-	43988A	1	43917A	1	-	-
A95 S/H-32	Suzuki® / Honda®	43901J	43913C	1	-	-	43988A	2	-	-	-	-
A95 S/H-37.5	Suzuki® / Honda®	43902L	43919E	1	-	-	43988A	2	-	-	-	-
A97 S/H-30	Suzuki® / Honda®	43905T	43921R	2	-	-	43988A	2	43917A	1	-	-
A97 S/H-35.5	Suzuki® / Honda®	43906V	43919E	2	-	-	43988A	2	43917A	1	-	-
A98 S/H	Suzuki® / Honda®	43909B	43921R	2	43920N	1	43988A	2	43917A	2	-	-

### Liquid Tie Bars

**LTB1** - 42085Z

**LTB1N** - 43525G

Liquid Tie Bars for twin engine / twin cylinder applications where a mechanical tie bar is not feasible. Engine centers must be at least 38" wide as engine can periodically misalign. They connect using standard Kit OB or Kit OB/R5.SVS hoses.

The Liquid Tie Bars should not be used on any applications with engine centers less than 36"

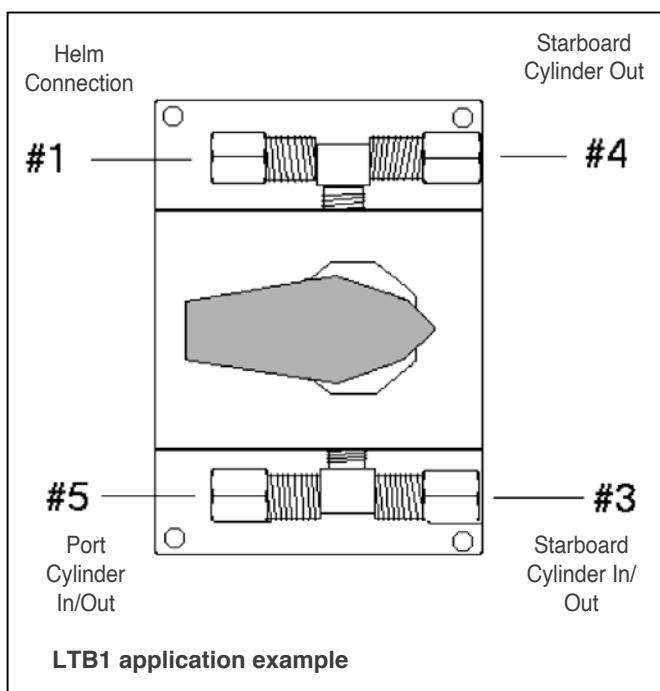

LTB1



LTB1N

# Masterdrive™ Power Assisted Outboard Steering System



MasterDrive power assisted outboard steering system delivers effortless steering for the most demanding applications, regardless of speed or torque conditions.

## MasterDrive System features

- Eliminates torque at the steering wheel
- Three different selectable levels of power give the driver the desired feeling on the wheel (PATENTED).
- Automatically reverts to manual mode in case of power loss.
- High efficiency, low Amp draw, low noise
- The system always running permits immediate control in any sea conditions
- Equipped with safety switch ON/OFF (SMART BUTTON)
- Suitable for dual station installations and for use with autopilot
- Voltage: 12VDC
- CE marked in conformity with ABYC P21, ISO 10592 safety standards, Ignition protected (SAE J-1171 and UNI EN 28846)

SYSTEM APPLICATIONS	MasterDrive™
Max. relief valve for the hydraulic steering system	105 bar
Control unit operation pressure	35 bar
Speed allowed	60 knots - 65 knots for two engines, dual cylinder, counter rotating propeller applications



## Components

- 1 single packaged KIT MD for single station containing:
    - 1 **UH**-front or tilt mount Main Helm
    - 1 **UPMD** Power Unit, 15' (4,5 m) wiring harness included
    - 1 **UCMD** User Interface
    - 4 **OIL 15** bottles of hydraulic oil
    - Anti-vibration sleeves
  - **UC128-SVS** SilverSteer Steering Cylinder (1 UC128-SVS starboard+1 UC128/P-SVS port on dual cylinder applications)
  - 2 **KIT OB-SVS**: SilverSteer high pressure hose kit, helm-power unit connection, complete with preassembled fittings.
  - **KIT OB-DBR-SVS**: SilverSteer high pressure hose kit complete with preassembled fittings for cylinder connection
  - 1 Tilt mechanism **X88-44006L** suitable for Tilt Mount Helm. Tilt range of 48° and five locking positions.
  - 1 Dual cylinder application Tie Bar: see selection
  - 1 Steering Wheel: see selection
  - 1 Instruction Manual
- **Masterdrive™ is available with or without interface panel**

# Masterdrive™ Power Assisted Outboard Steering System

## UH - HELM

- Available in two different displacement sizes: 32 cc (1.95 cu.in) and 40 cc (2.44 cu.in)
- Front Mount and Tilt Mount versions
- Dual station installation version also available (please refer to MD2 Kit)
- Built-in relief valve
- 3/4" tapered shaft
- Corrosion resistant painted body
- Waterproof
- Tilt Mount version is suitable for use with X66-40613 M tilt mechanism



UH

MODEL	P. No.	MOUNTING	DISPLACEMENT/ REVOLUTION	APPLICATION	No. OF STATIONS	MAXIMUM WHEEL DIA.
UH32-F	42091U	front mount	32cc - 1.95 cu.in	single cylinder	1	406 mm - 16"
UH32-T	42092W	with X66 tilt	32cc - 1.95 cu.in	single cylinder	1	406 mm - 16"
UH40-F	42093Y	front mount	40cc - 2.44 cu.in	dual cylinder	1	406 mm - 16"
UH40-T	42095C	with X66 tilt	40cc - 2.44 cu.in	dual cylinder	1	406 mm - 16"

UH32: wheel turns lock-to-lock in single cylinder applications: **3,75**

UH40: wheel turns lock-to-lock in dual cylinder applications: **6**

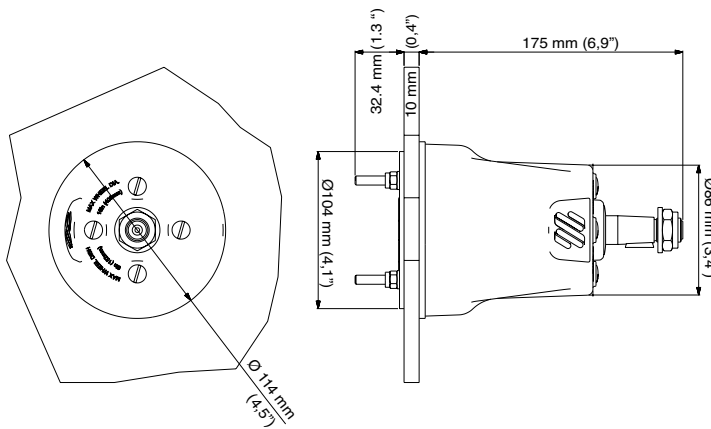

UH32-F and UH40-F dimensions

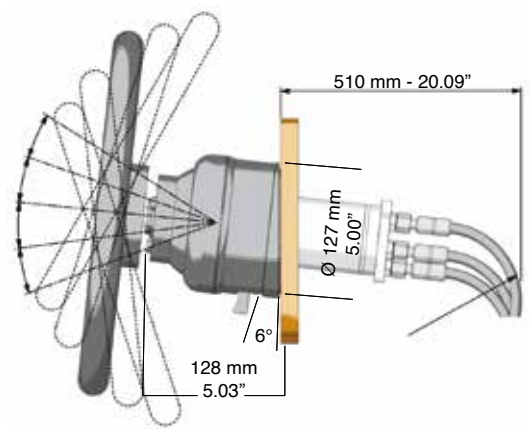

UH32-T and UH40-T dimensions

## X88 - Tilt mechanism- 44406L

Tilt mechanism for MasterDrive™ tilt mount helms.  
Tilt range of 48° and five locking positions

## 90° FITTING FOR MASTERDRIVE HELMS (OPTIONAL)

- MD 38 NI COM FT - 42821F



X88

MD 38 NI COM FT



# Masterdrive™ Power Assisted Outboard Steering System

## K81 / K81MM - Intermediate helm position installation kit (optional)

- **K81** - 42435A  
Kit to permit the MasterDrive helm installation at any intermediate dashboard position
- **K81MM** - 42498B  
Suitable version for Mercury® Verado™ power-assisted helm.



K81



K81MM



## UPMD - Power Unit - 42096E

- 12VDC Motor
- 45° swiveling fittings for easy installation
- Semitransparent 0,5 litre (0.11gal) tank gives immediate oil level vision
- Vented filler plug
- Suitable for applications with autopilot
- Bulkhead or floor mount
- Black galvanized motor case, salt water resistant
- 4,5 m (15') Wiring Harness included
- IP67 waterproof
- Ignition protected (SAE J-1171 and UNI EN 28846)

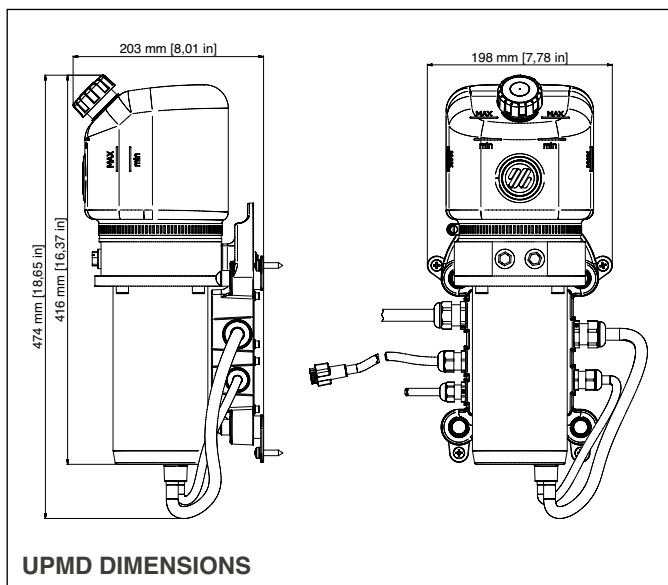

UPMD



**Note: UPMD-NP 44039C Power Unit** for applications without UCMD user interface - available upon request



# Masterdrive™ Power Assisted Outboard Steering System

## UCMD - User interface - 42097G

- Safety switch ON/OFF (SMART BUTTON)
- Three different power levels with light indicator (PATENTED)
- Motor temperature visual indicator
- Twin engine key selection included
- Lighted panel for stand-by position
- Plug-in wiring harness
- Suitable for a second station installation
- 7 m (23 ft) panel extension cable also available 42636L



UCMD

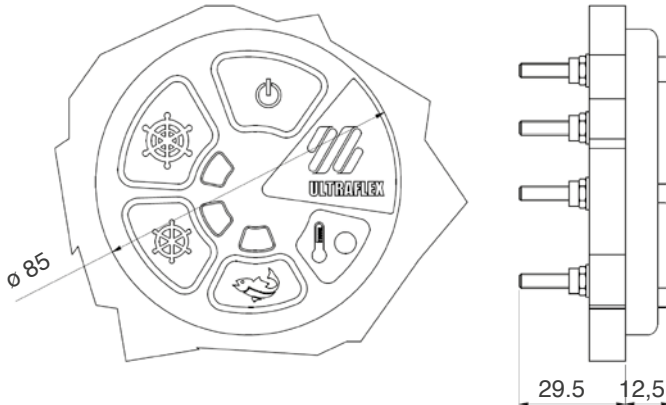

UCMD DIMENSIONS

## MD - packaged kit for single station

MasterDrive packaged kit contains:

- 1x **UH** Main Helm Pump
- 1x **UPMD** Power Unit, 15' (4,5 m) wiring harness included
- 1x **UCMD** User Interface
- 4 quarts **OIL 15** hydraulic oil
- Anti-vibration sleeves
- Installation Manual

Depending on the helm type, different versions are available:

For more details please, refer to the kit offering selection.

The SilverSteer UC130-SVS cylinder, the hydraulic hose kits, the **X66** - 40613M tilt mechanism, the tie bar and the wheel are to be ordered separately

23 ft (7 m) Panel extension cable also available - 42636L



MD KIT

## MasterDrive™ Hose kits



KIT OB-SVS	LENGTH
KIT OB-SVS-3	3.0 ft
KIT OB-SVS-4	4.0 ft
KIT OB-SVS-5	5.0 ft
KIT OB-SVS-6	6.0 ft
KIT OB-SVS-8	8.0 ft
KIT OB-SVS-10	10.0 ft
KIT OB-SVS-12	12.0 ft
KIT OB-SVS-14	14.0 ft
KIT OB-SVS-16	16.0 ft
KIT OB-SVS-18	18.0 ft
KIT OB-SVS-20	20.0 ft



**KIT OB-SVS**

## KIT OB-DBR-SVS: DUAL CYLINDER/DUAL ENGINE CONNECTION KIT FOR UC128-SVS

KIT OB-SVS	LENGTH
KIT OB-DBR-SVS-22in	22 in
KIT OB-DBR-SVS-02	2.0 ft
KIT OB-DBR-SVS-025	2.5 ft
KIT OB-DBR-SVS-03	3.0 ft
KIT OB-DBR-SVS-04	4.0 ft
KIT OB-DBR-SVS-05	5.0 ft
KIT OB-DBR-SVS-06	6.0 ft



**KIT OB-DBR-SVS**

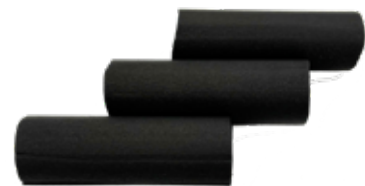

**KIT ANTI-VIBRATION SLEEVES - 77970W**

# Masterdrive™ Power Assisted Outboard Steering System

## Single cylinder single station application

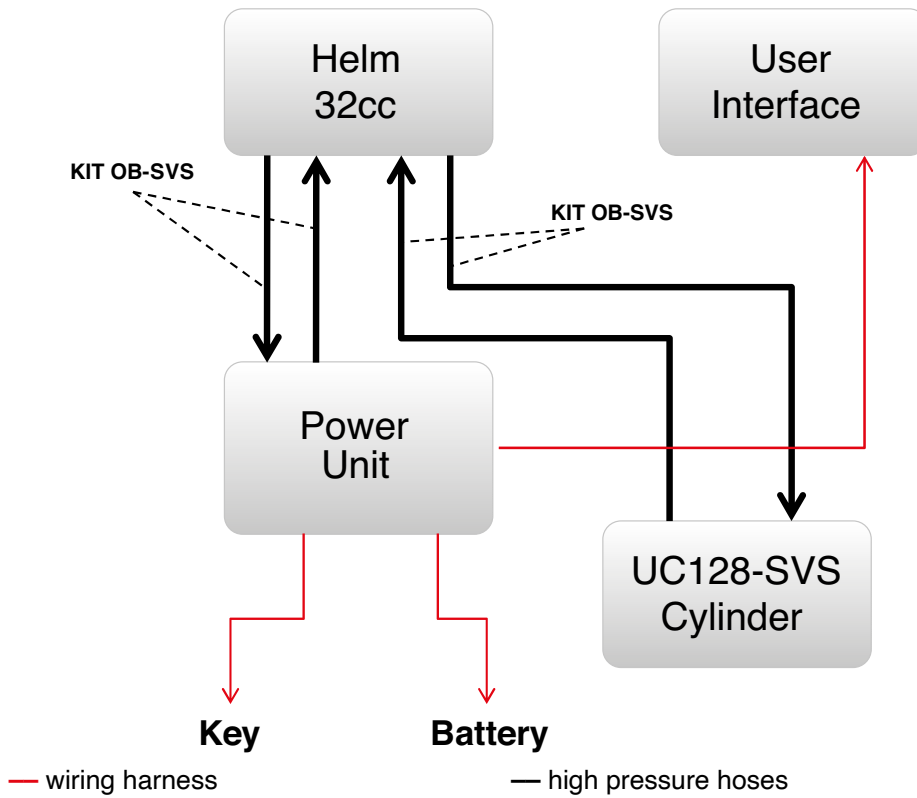

## Dual cylinder single station application

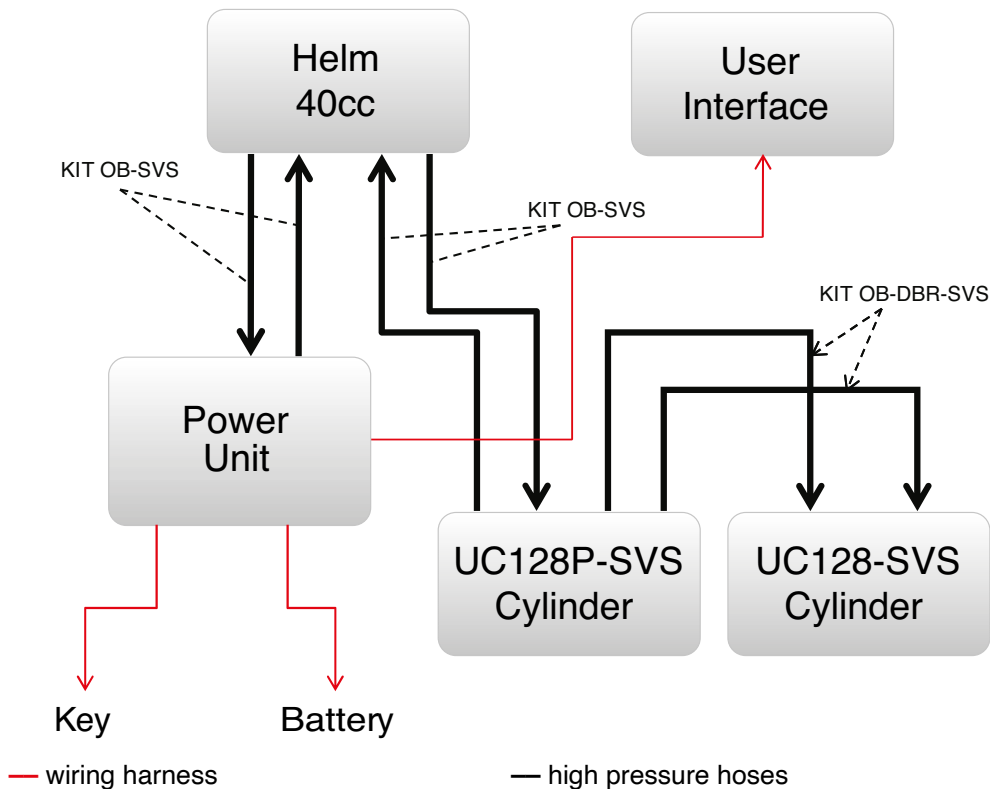

## SINGLE STATION / SINGLE CYLINDER KITS

MD32-1F	KIT INCLUDES
<b>UH32-F</b> <b>UCMD</b> <b>UPMD</b> <b>UC128-SVS/1</b> <b>OIL 15</b>	MasterDrive 32cc front mount helm MasterDrive user interface MasterDrive power unit 12V DC UC128 SilverSteer cylinder ver 1 2 quarts of OIL 15
MD32-2F	KIT INCLUDES
<b>UH32-F</b> <b>UCMD</b> <b>UPMD</b> <b>UC128-SVS/2</b> <b>OIL 15</b>	MasterDrive 32cc front mount helm MasterDrive user interface MasterDrive power unit 12V DC UC128 SilverSteer cylinder ver 2 2 quarts of OIL 15

MD32-1T	KIT INCLUDES
<b>UH32-T-X88</b> <b>UCMD</b> <b>UPMD</b> <b>UC128-SVS/1</b> <b>OIL 15</b>	MasterDrive 32cc tilt mount helm with tilt mechanism for power steering MasterDrive user interface MasterDrive power unit UNIT 12V DC UC128 SilverSteer cylinder ver 1 2 quarts of OIL 15
MD32-2T	KIT INCLUDES
<b>UH32-T-X88</b> <b>UCMD</b> <b>UPMD</b> <b>UC128-SVS/2</b> <b>OIL 15</b>	MasterDrive 32cc tilt mount helm with tilt mechanism for power steering MasterDrive user interface MasterDrive power unit UNIT 12V DC UC128 SilverSteer cylinder ver 2 2 quarts of OIL 15

## SINGLE STATION RETROFIT KITS

MD32-FM	KIT INCLUDES
<b>UH32-F</b> <b>UCMD</b> <b>UPMD</b>	MasterDrive 32cc front mount helm MasterDrive user interface MasterDrive power unit 12V DC
MD40-FM	KIT INCLUDES
<b>UH40-F</b> <b>UCMD</b> <b>UPMD</b>	MasterDrive 40cc front mount helm MasterDrive user interface MasterDrive power unit 12V DC

MD32-T	KIT INCLUDES
<b>UH32-T-X88</b> <b>UCMD</b> <b>UPMD</b>	MasterDrive 32cc tilt mount helm with tilt mechanism for power steering MasterDrive user interface MasterDrive power unit UNIT 12V DC
MD40-T	KIT INCLUDES
<b>UH40-T-X88</b> <b>UCMD</b> <b>UPMD</b>	MasterDrive 40cc tilt mount helm and tilt mechanism for power steering MasterDrive user interface MasterDrive power unit UNIT 12V DC

## SINGLE STATION / TWIN CYLINDER KITS

MD40-D1F	KIT INCLUDES
<b>UH40-F</b> <b>UCMD</b> <b>UPMD</b> <b>UC128-SVS/1</b> <b>UC128P-SVS/1</b> <b>OIL 15</b>	MasterDrive 40cc front mount helm MasterDrive user interface MasterDrive power unit 12V DC UC128 SilverSteer cylinder ver 1 UC128 SilverSteer cylinder ver 1P 2 quarts of OIL 15
MD40-D2F	KIT INCLUDES
<b>UH40-F</b> <b>UCMD</b> <b>UPMD</b> <b>UC128-SVS/2</b> <b>UC128P-SVS/2</b> <b>OIL 15</b>	MasterDrive 40cc front mount helm MasterDrive user interface MasterDrive power unit 12V DC UC128 SilverSteer cylinder ver 2 UC128 SilverSteer cylinder verP 2 quarts of OIL 15

MD40-D1T	KIT INCLUDES
<b>UH40-T-X88</b> <b>UCMD</b> <b>UPMD</b> <b>UC128-SVS/1</b> <b>UC128P-SVS/1</b> <b>OIL 15</b>	MasterDrive 40cc tilt mount helm with tilt mechanism for power steering MasterDrive user interface MasterDrive power unit 12V DC UC128 SilverSteer cylinder ver 1 UC128 SilverSteer cylinder ver 1P 2 quarts of OIL 15
MD40-D2T	KIT INCLUDES
<b>UH40-T-X88</b> <b>UCMD</b> <b>UPMD</b> <b>UC128-SVS/2</b> <b>UC128P-SVS/2</b> <b>OIL 15</b>	MasterDrive 40cc tilt mount helm with tilt mechanism for power steering MasterDrive user interface MasterDrive power unit 12V DC UC128 SilverSteer cylinder ver 2 UC128 SilverSteer cylinder verP 2 quarts of OIL 15

**NOTE:** On request, Power Unit wiring harness can be cut to length required  
**7 m (23 ft) Panel extension cable also available - 42636L**

**Attention:**  
 MasterDrive system is intended for use with SilverSteer™ UC128-SVS or UC130-SVS cylinders only

# UC133-IOB / UC132-OBS Sterndrive cylinders

## UC133-IOB - Sterndrive Cylinder



- Balanced cylinder: the number of turns lock to lock is equal port to starboard or vice-versa
- This side mount cylinder features a turning nut for a fast and easy installation to the engine tube (PATENTED)



APPLICATIONS: not recommended for use in installations where the boat speed exceeds 55 mph (48 knots)  
Not intended for use in racing application

## UC132-OBS - Side Mount Cylinder

UC132-OBS Unbalanced: the wheel number of turns lock-to-lock is not equal port to starboard and vice-versa

- This side mount cylinder features a turning nut for a fast and easy installation to the engine tube (PATENTED)
- Clearance required at the engine tube side: 375 mm (14.76")



APPLICATIONS: not recommended for use in installations where the boat speed exceeds 55 mph (48 knots) (60 mph (52 knots) for dual cylinder / dual engines installations)  
Not intended for use in racing applications

**WARNING:** UC132-OBS cylinder is not intended for use with 105 Bar (1500 PSI) SilverSteer series helms.

SPECIFICATIONS	UC133-IOB - 39429 M Balanced	UC132-OBS - 39430 W Unbalanced
Volume	132 cc - 8 cu. in	132 / 163 cc - 8 / 9.95 cu. in
Torque	66 kgm - - 5738 lbs. in	
Output force	464 kg -1023 lbs	464 / 574 kg - 1023 / 1265 lbs
Inside diameter	32 mm - 1.25"	32 mm - 1.25"
Stroke	203 mm - 8"	203 mm - 8"
3/8" (9,5 mm) Fittings	For high pressure flex hose	For high pressure flex hose

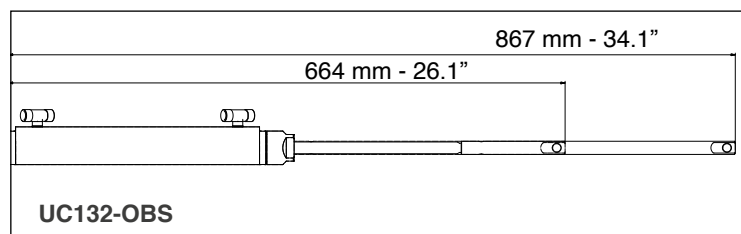
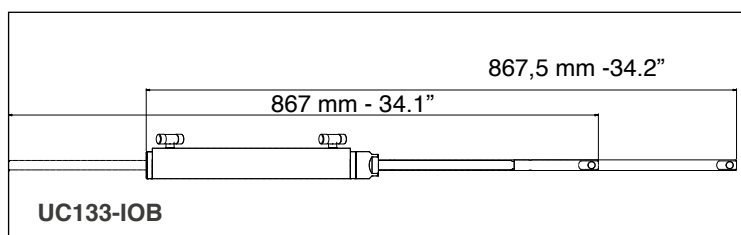

### KIT 95 - 39516G:

3/8" copper tube fitting kit. It includes one 3.2 ft (1 m) nylon tubes and all necessary fittings for a single station.

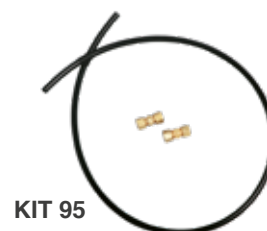

KIT 95

## Applications

**WARNING** These recommendations should be used as general reference only and they apply to factory stock sterndrives only. In doubt, contact a qualified installation technician.

ENGINE	YEAR	MODEL	STERDRIVE CYLINDERS			
			non power assist engine	see notes	power assisted engine	see notes
MERCUISER®	To date	ALPHA	UC133-IOB	1, 3	UC132-OBS	2
	To date	BRAVO ONE	UC133-IOB	1, 3	UC132-OBS	2
	To date	BRAVO TWO	UC133-IOB	1, 3	UC132-OBS	2
	To date	BRAVO THREE	UC133-IOB	1, 3	UC132-OBS	2
VOLVO®	To date	275	UC168-I		N/D	
	To date	280	UC133-IOB	1, 3, 4	UC132-OBS	2
	To date	290	UC133-IOB	1, 3, 4	UC132-OBS	2
	To date	DP-E	UC133-IOB	1, 3, 5	UC133V-IOB	
	To date	DP-G	N/A		UC133V-IOB	
	To date	DP-S	N/A		UC132-OBS	2
YANMAR®	To date	ZT350	N/A		UC132-OBS	2

- Balanced cylinder** the number of turns lock to lock is equal port to starboard or vice-versa
- Unbalanced cylinder** the number of turns lock to lock is not equal port to starboard or vice-versa
- Clearance required at the engine tube side: 21.2" (540 mm).**
- ULTRAFLEX hydraulic cylinder** can be installed as an alternative to a mechanical steering system only.
- The Volvo P. No. 872388 adaptor fitting is required for the installation.**

**NOTE:** For applications with sterndrive engines not listed above, please contact our Technical Service.

## Order guide

**NOTE:** 3/8" or 10 mm diameter copper tubing can be used as an alternative tubing for plumbing the systems. For these applications a fitting kit – KIT 95 or KIT 100 – is required.

**Turn lock to lock: Balanced 4.7 - Unbalanced 4.7/5.8**  
**Max rudder torque: 66 kgm - 5738 lbs. in**

Components	Model	Qty	
Helm pump	UP28	1	For additional station add: 1 UP28 helm pump, 1 KIT OB-2S fitting kit, 1 KIT OB hose Kit, extra OL 150, 1 steering wheel
Cylinder	see application	1	
Hose kit	KIT OB	1	
Oil	OL 150	3	
Steering wheel	(Wheel selection)	1	

**Turn lock to lock: Balanced 4 - Unbalanced 4/5**  
**Max rudder torque: 66 kgm - 5738 lbs. in**

Components	Model	Qty	
Helm pump	UP33	1	For additional station add: 1 UP33 helm pump, 1 KIT OB-2S fitting kit, 1 KIT OB hose Kit, extra OL 150, 1 steering wheel
Cylinder	see application	1	
Hose kit	KIT OB	1	
Oil	OL 150	3	
Steering wheel	(Wheel selection)	1	



# Bulkhead hose kits

## R5 - R5SS Bulkhead strain relief hose kit

R5 kit distributes strain from bends in hose. It features a water tight gripper fitting and a bulkhead fitting flange for hose protection.

R5	39510U	Bulkhead hose kit
R5SS	42419C	Bulkhead hose kit with stainless steel flange



R5



R5SS

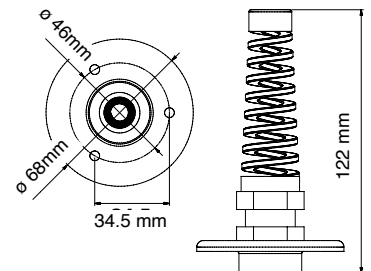

R5 DIMENSIONS

## R7 - 3/4" Bulkhead fitting kit



R7 KIT

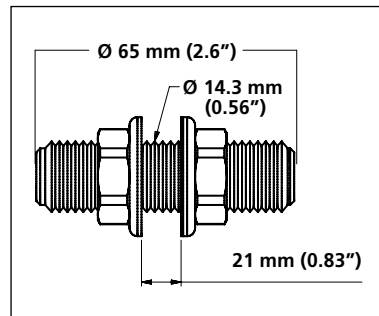

R7 DIMENSIONS

3/4" bulkhead fitting kit for single cylinder installation. 2 assemblies as illustrated per kit.

R7	40819J	3/4" bulkhead fitting kit
----	--------	---------------------------

## R8 - Dual thru-hull hose kit



R8B



R8W



R8CH

Connection flange available in three different colours

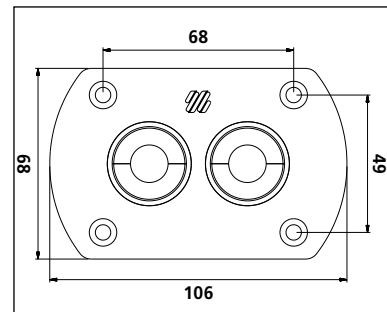

R8 DIMENSIONS

R8B	41299P	Connection flange - black
R8W	41300V	Connection flange - white
R8CH	41301X	Connection flange - chrome plated

## R9 Bulkhead kit for dual hose with preassembled fittings



R9B



R9W



R9CH

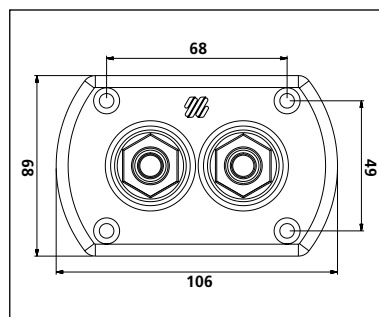

R9 DIMENSIONS

Connection flange available in three different colours

R9B	43165C	Connection flange - black
R9W	43167G	Connection flange - white
R9CH	43166E	Connection flange - chrome plated

## ACCESSORIES

### TU95:

3/8" nylon tubing. It is not recommended in the applications where the total tubing run exceeds 50 ft (15 m). Not recommended for use with UC128-OBF, UC128-SVS and UC130-SVS cylinders.

### KIT 95-2S - 43184G:

Fitting kit for a second steering station or for an autopilot installation.

It includes:

- (1) 40800L - Non Vented Cap
- (2) CONNECTOR FITT. - 1/4npt to 3/8 straight fitting
- (2) UNION T - 3/8" Tube Brass T Fitting

**OIL 15** - 70704K: Hydraulic oil sold in 0.26 gallons (1 litre) bottle

**OIL 15 55D:** Hydraulic oil sold in 55 gallon drum

- hydraulic oil: 150 VG 15
- solidification point: < -30°C
- contamination according to NAS1638 ≤ 8

**KIT F** - 39664Y: Remote fill adapter for rear mount and tilt mount pumps.



KIT 95-2S



OIL 15



KIT F

# Fittings

Model	Description	Typical Application	Thread
<b>AF45</b> 41284A	 45 DEGREE ADJUSTABLE FITTING	Fitting for the back of the UP series helms	"ORB, Size #6 to 3/8 COMP FITTING" Helm Side = 9/16 - 18 UNF 2A Hose Side = 9/16 - 24 UNEF 2A
<b>AF90</b> 74144U	 90 DEGREE ADJUSTABLE FITTING	Fitting for the back of the UP series helms	"ORB, Size #6 to 3/8 COMP FITTING" Helm Side = 9/16 - 18 UNF 2A Hose Side = 9/16 - 24 UNEF 2A
<b>71928P</b>	 BRASS PLUG W/ORING FOR PUMPS	Compensating line brass plug of the UP series helms	"1/4 NPT PLUG" Helm Side = 1/4 NPT
<b>SF18</b> 43179P	 STRAIGHT HELM FITTING 1/8"	Fitting for the compensating line in the UP series helms or autopilot return line	-
<b>SF38</b> 39471L	 STRAIGHT HELM FITTING 1/4 NPT	Fitting for the compensating line in the UP series helms or autopilot return line	"1/4 NPT to 3/8 COMP FITTING " Helm Side = 1/4 NPT Hose Side = 9/16 - 24 UNEF 2A
<b>EF38</b> 39472N	 90° HELM FITTING FOR UP SERIES	Fitting for port / starboard line in the UP series helms prior to the boss fittings	"1/4 NPT to 3/8 COMP FITTING " Helm Side = 1/4 NPT Hose Side = 9/16 - 24 UNEF 2A
<b>71955T</b>	 BOSS STYLE T-FITTING NICKEL	Fitting for back of helm in a dual station installation	"ORB, Size #6 to 3/8 COMP FITTING" Cylinder/Helm Side = 9/16 - 18 UNF 2A Hose Side = 9/16 - 24 UNEF 2A
<b>T-FITTING</b>	 1/4 NPT TO 3/8 T- FITTING	Fitting used in the back of the previous version of the UP series helms before the boss fitting	"1/4 NPT to 3/8 COMP FITTING" Helm/Side = 1/4 NPT Hose Side = 9/16 - 24 UNEF 2A
<b>VFNO38</b> 40868Y	 COMPLETE BOSS FITTING UC1280BF	Bleed fitting for all outboard cylinders	"ORB, Size #6 to 3/8 COMP FITTING" Cylinder Side = 9/16 - 18 UNF 2A Hose Side = 9/16 - 24 UNEF 2A
<b>71861H</b>	 T-FITTING ASSEMBLY-ORF HOSE	Used to replace the boss fitting in new outboard cylinders when trying to connect 'O' ring face seal hoses	"ORB, Size #6 to 3/8 COMP FITTING" Cylinder Side = 9/16 - 18 UNF 2A Hose Side = 9/16 - 24 UNEF 2A
<b>VFN38</b> 39925A	 TEE FITTING WITH BLEED NIPPLE	Bleed fitting for all inboard and stern drive cylinders	"1/4 NPT to 3/8 COMP FITTING" Cylinder Side = 1/4 NPT Hose Side = 9/16 -24 UNEF 2A
<b>TF38</b> 39502V	 UNION T-FITTING FOR 3/8" TUBE	T-Fitting for 3 standard 3/8" compression thread hose fittings	"3/8 COMP FITTING" ALL Sides = 9/16 - 24 UNEF 2A

Model	Description	Typical Application	Thread
61BCA 71004K	 BRASS NUT W/SLEEVE #61CA-6	3/8" Compression Nut with ferrule for cut to length nylon tubing	"3/8 COMP NUT" Side = 9/16 - 24 UNEF 2B Hose Side = 3/8 Compression Ferrule
UNION 62CA-6	 UNION 3/8 IN COMPRESSION	Used to connect 2 standard 3/8" Compression hoses	"3/8 COMP FITTING" Both Sides = 9/16 - 24 UNEF 2A
MD 38 NI COM FT	 90° 3/8 NI PLATE COMP FITTING	90° fitting from bulkhead fitting to 3/8" compression hose	"3/8 COMP FITTING" Fitting side = 9/16 - 24 UNEF 2B Hose Side = 9/16 - 24 UNEF 2A
Q22 898366	 TAPARED HELM FITTING TO MERCURY 'O' RING	Fitting for the back of the Merc UP series helms to 'O' ring face seal Hoses	1/4 NPT to ORFS Fitting Side = 1/4 NPT Hose Side = ORFS ('O' rin Face)
UPS 11/16 ELBOW	 POWERTECH 11/16, 90 DEG ELBOW	90° fitting for the pressure and tank line on a poertech helm	-
UPS 90 DEG ELB	 POWERTECH 90 DEGREE ELBOW	90° fitting for the two high pressure outlets on a powertech helm/also used for connection from a bulkhead	-
UPS BLKHD T-FIT	 POWERTECH BULKHEAD T-FITTING	T-Fitting used on bulkhead fittings or helm high pressure lines on powertech helm	-
UPS T-FITTING	 POWERTECH T-FITTING	3-way ORF fitting for Mercury style ORF hoses	-
UPS UNION	 POWERTECH UNION FOR KITPS/PSDS	11/16" union to extend a KITPS/KITPSDS hose	-
UPS UNION OB	 POWERTECH UNION FOR KITOBPS	ORF to ORF union for connection of high pressure ORF style hoses	-
UPS 4-4 FLO-SS	 POWERTECH MALE CONNECTOR	Used when connecting an Autopilot to Powertech System - Autopilot to ORF Hose	-

# HYDRAULIC CROSS REFERENCE GUIDE

UFLEX® PART No.	SEASTAR® CROSS REFERENCE	DESCRIPTION
<b>HYDRAULIC HELM UNITS - FRONT MOUNT</b>		
UP20 F	HH5270	FRONT MOUNT HELM, 1.2 CU.IN. 3/4" ANODIZED ALUM. TAPERED SHAFT
UP25 F	HH5271	FRONT MOUNT HELM, 1.5 CU.IN. 3/4" TAPERED STAINLESS STEEL SHAFT
UP28 F	HH5271	FRONT MOUNT HELM, 1.7 CU.IN. 3/4" TAPERED STAINLESS STEEL SHAFT
UP33 F	HH5273	FRONT MOUNT HELM, 2.0 CU.IN. 3/4" TAPERED STAINLESS STEEL SHAFT
UP39 F	HH5272	FRONT MOUNT HELM, 2.4 CU.IN. 3/4" TAPERED STAINLESS STEEL SHAFT
UP45 F	-	FRONT MOUNT HELM, 2.7 CU.IN. 3/4" TAPERED STAINLESS STEEL SHAFT
<b>HYDRAULIC HELM UNITS - TILT MOUNT</b>		
UP20 T	HH5291 or HH5740 or HH4315	TILT HELM, 1.2 CU.IN. 3/4" TAPERED SS SHAFT (X52 TILT INCLUDED & KIT F OPTIONAL)
UP25 T	HH5291 or HH5741 or HH6191 or HH6491 or HH6541	TILT HELM, 1.5 CU.IN. 3/4" TAPERED SS SHAFT (X52 TILT INCLUDED & KIT F OPTIONAL)
UP28 T	HH5291 or HH5741 or HH6191 or HH6491 or HH6541	TILT HELM, 1.7 CU.IN. 3/4" TAPERED SS SHAFT (X52 TILT INCLUDED & KIT F OPTIONAL)
UP33 T	HH5290 or HH5774 or HH6145 or HH6490	TILT HELM, 2.0 CU.IN. 3/4" TAPERED SS SHAFT (X52 TILT INCLUDED & KIT F OPTIONAL)
UP39 T	HH5292 or HH5742 or HH6192 or HH6492 or HH6542	TILT HELM, 2.4 CU.IN. 3/4" TAPERED SS SHAFT (X52 TILT INCLUDED & KIT F OPTIONAL)
UP45 T	-	TILT HELM, 2.7 CU.IN. 3/4" TAPERED SS SHAFT (X52 TILT INCLUDED & KIT F OPTIONAL)
<b>HYDRAULIC HELM UNITS - REAR MOUNT</b>		
UP28 R	HH5261	BACK MOUNT 1.7 CU.IN. 3/4" TAPERED SS SHAFT *(KIT F OPTIONAL)
UP33 R	HH5262	BACK MOUNT 2.0 CU.IN. 3/4" TAPERED SS SHAFT *(KIT F OPTIONAL)
UP39 R	HH5263	BACK MOUNT 2.4 CU.IN. 3/4" TAPERED SS SHAFT *(KIT F OPTIONAL)
UP56 R	HH5263	BACK MOUNT 3.4 CU.IN. 3/4" TAPERED SS SHAFT
<b>BASS BOAT TOP PERFORMANCE 1500 PSI HELM UNITS</b>		
UP25FM-BB	HH5779-3	1500 PSI-HIGH PERFORMANCE FRONT MOUNT HELM, 1.5 CU.IN. 3/4" TAPERED SS SHAFT
UP28FM-BB	HH5779-3	1500 PSI-HIGH PERFORMANCE FRONT MOUNT HELM, 1.7 CU.IN. 3/4" TAPERED SS SHAFT
UP33FM-BB	HH5770-3	1500 PSI-HIGH PERFORMANCE FRONT MOUNT HELM, 2.0 CU.IN. 3/4" TAPERED SS SHAFT
UP25T-BB	HH6189	1500 PSI-HIGH PERFORMANCE TILT HELM, 1.5 CU.IN. TAPERED SS *(KIT F OPTIONAL)
UP28T-BB	HH6189	1500 PSI-HIGH PERFORMANCE TILT HELM, 1.7 CU.IN. TAPERED SS *(KIT F OPTIONAL)
UP33T-BB	HH6190	1500 PSI-HIGH PERFORMANCE TILT HELM, 2.0 CU.IN. TAPERED SS *(KIT F OPTIONAL)
<b>OUTBOARD APPLICATION CYLINDERS (See application chart)</b>		
UC128-OBF/1	HC5345 or HC5358	CYLINDER, 1.38" BORE, 7.8" STROKE, FRONT MOUNT - # 1 LINK ARM
UC128-OBF/2	HC5345 or HC5358	CYLINDER, 1.38" BORE, 7.8" STROKE, FRONT MOUNT - # 2 LINK ARM
UC128-OBF/3	HC5345 or HC5358	CYLINDER, 1.38" BORE, 7.8" STROKE, FRONT MOUNT - # 3 LINK ARM
UC128P-OBF/1	HC5345 or HC5358	CYLINDER, 1.38" BORE, 7.8" STROKE, FRONT MOUNT - PORT ENGINE CYLINDER - # 1 LINK ARM
UC128P-OBF/2	HC5345 or HC5358	CYLINDER, 1.38" BORE, 7.8" STROKE, FRONT MOUNT - PORT ENGINE CYLINDER - # 2 LINK ARM
<b>SILVER STEER OUTBOARD APPLICATION CYLINDERS (See application chart)</b>		
UC128SVS/1	HC6345 - HC6347 - HC6348	HIGH PERFORMANCE CYLINDER, 1.38" BORE, 7.8" STROKE, FRONT MOUNT - # 1 LINK ARM
UC128SVS/2	HC6345 - HC6347 - HC6348	HIGH PERFORMANCE CYLINDER, 1.38" BORE, 7.8" STROKE, FRONT MOUNT - # 2 LINK ARM
UC128BB/1	HC6845 - HC6845S	HIGH PERFORMANCE CYLINDER, 1.38" BORE, 7.8" STROKE, FRONT MOUNT - # 1 LINK ARM
UC128BB/2	HC6845 - HC6845S	HIGH PERFORMANCE CYLINDER, 1.38" BORE, 7.8" STROKE, FRONT MOUNT - # 2 LINK ARM
<b>MID HP OUTBOARD APPLICATION CYLINDERS (See application chart)</b>		
UC95-OBF/1	HC4645-3 or HC4648-3 HC4658-3	CYLINDER, 1.18" BORE, 7.3" STROKE, FRONT MOUNT (175 HORSEPOWER AND UNDER) - # 1 LINK ARM
UC95-OBF/2	HC4645-3 or HC4658-3 or HC4648-3	CYLINDER, 1.18" BORE, 7.3" STROKE, FRONT MOUNT (150 HORSEPOWER AND UNDER) - # 3 LINK ARM
UC95-OBF/3	HC4647-3	CYLINDER, 1.18" BORE, 7.3" STROKE, FRONT MOUNT (175 HORSEPOWER AND UNDER) - # 3 LINK ARM

# HYDRAULIC CROSS REFERENCE GUIDE

UFLEX® PART No.	SEASTAR® CROSS REFERENCE	DESCRIPTION
<b>SIDEMOUNT OUTBOARD CYLINDER</b>		
UC132-OBS	HC5370	CYLINDER, 1.26" BORE, 8.0" STROKE, SIDE MOUNT
GOTECH™	NOT APPLICABLE	FRONT MOUNT HYDRAULIC SYSTEM FOR UNDER 115 HP
<b>HYTECH OUTBOARD STEERING PACKAGES (See application chart)</b>		
HYTECH 1.1	HK4200a - BayStar®	FRONT MOUNT OUTBOARD SYSTEM FOR 175 HP AND LESS
HYTECH 2.1	HK4200a - BayStar®	FRONT MOUNT HYDRAULIC SYSTEM FOR 175 HP AND LESS
HYTECH 1.1T	NOT APPLICABLE	TILT MOUNT HYDRAULIC SYSTEM FOR 175 HP AND LESS
HYTECH 3.1	NOT APPLICABLE	FRONT MOUNT HYDRAULIC SYSTEM FOR 175 HP AND LESS
<b>PROTECH OUTBOARD STEERING PACKAGES (See application chart)</b>		
PROTECH 1	HK6300 or HK6400 SeaStar®	FRONT MOUNT OUTBOARD SYSTEM
PROTECH 2	HK6300 or HK6400 SeaStar®	FRONT MOUNT OUTBOARD SYSTEM
PROTECH 3	HK6300 or HK6400 SeaStar®	FRONT MOUNT OUTBOARD SYSTEM
PROTECH 1T	HK6400TC or HK6400TS or HK6500YTC SeaStar®	FRONT MOUNT OUTBOARD SYSTEM WITH TILT HELM
PROTECH 2T	HK6400TC or HK6400TS or HK6500YTC SeaStar®	FRONT MOUNT OUTBOARD SYSTEM WITH TILT HELM
PROTECH 3T	HK6400TC or HK6400TS or HK6500YTC SeaStar®	FRONT MOUNT OUTBOARD SYSTEM WITH TILT HELM
<b>SILVER STEER OUTBOARD STEERING PACKAGES (See application chart)</b>		
SILVER STEER 1	HK7300 or HK7400 SeaStar Pro®	1500PSI HI-PERFORMANCE FRONT MOUNT OUTBOARD SYSTEM
SILVER STEER 2	HK7300 or HK7400 SeaStar Pro®	1500PSI HI-PERFORMANCE FRONT MOUNT OUTBOARD SYSTEM
SILVER STEER 1T	HK7300 or HK7400 SeaStar Pro®	1500PSI HI-PERFORMANCE FRONT MOUNT OUTBOARD SYSTEM WITH TILT HELM
SILVER STEER 2T	HK7300 or HK7400 SeaStar Pro®	1500PSI HI-PERFORMANCE FRONT MOUNT OUTBOARD SYSTEM WITH TILT HELM
<b>STERNDRIVE APPLICATION CYLINDERS</b>		
UC133-IOB	HC5330 or HC5332	CYLINDER, 1.26" BORE, 8" STROKE, BALANCED
UC132-OBS	HC5328	CYLINDER, 1.26" BORE, 8" STROKE, UNBALANCED
<b>HYDRAULIC PARTS AND ACCESSORIES</b>		
BUBBLE BUSTER	POWER PURGE®	PURGING SYSTEM FOR UFLEX HYDRAULIC STEERING SYSTEMS
KIT F	HA5450	REMOTE FILL KIT OF UP TILT HELMS AND UP REAR MOUNT HELMS
OIL 15	HA5430	UFLEX HYDRAULIC OIL, 1 QUART
X56	HA5417 or HA5418	SQUARE BEZEL FOR HYDRAULIC HELMS
X57	HA5417 or HA5419	ROUND BEZEL FOR HYDRAULIC HELMS
KIT OB-LL	HO51LL	PREMADE HYDRAULIC HOSES
KIT OB-BHBR-LL	HO81LL	PREMADE HYDRAULIC HOSES WITH BULKHEAD BEND RESTRICTORS
KITOB SVS-LL	HO81LL	TWO FLEXIBLE HOSES SILVER STEER HIGH PERFORMANCE
TU95-LL	HT5LL	NYLON TUBE IN 1 FT. INCREMENTS (NOT RECOMMENDED FOR OUTBOARD APPLICATIONS)
KIT 95 2S	HF5501	ADDITIONAL STATION FITTING KIT FOR 3/8" NYLON OR COPPER TUBE

**NOTE:** This cross reference is intended to be a general guide. Some of the products may have variances that would not make them interchangeable. We recommend that you contact Technical Service for more details.



# BubbleBuster™

## Portable device for automatic filling and purging of hydraulic systems

Reduce time and simplify purging hydraulic steering systems with the self contained and portable BubbleBuster™ purging unit.

Attach the hoses using the quick connect fittings to the helm and cylinder and with the push of a button the BubbleBuster™ begins cycling oil throughout the entire systems free of air.

The system features a ZeroEmulsion pump, 1 gal capacity reservoir and is compatible with competing helms and cylinders.

Zero Emulsion Effect



BubbleBuster™

MODEL	P. No.	DESCRIPTION
BB	41666R	BubbleBuster™ - complete set
KBE1	41682N	Extension kit
KBD2	41703U	Double cylinder purging kit
KH94	41899R	Connection kit for UC94-OBF cylinder with old fittings
KH128	41900W	Connection kit for cylinders with old fittings (except UC95)

## Components included

- No. 1 motor pump with safety valve , switch and 5 litres (1 gal) tank included, it allows the purging of 2 hydraulic steering systems before refilling.
- 12V electric motor with thermal protection. Current absorption 8 A
- No. 1 4m (13') electric harness with alligator clips for fast connection with the battery.
- No. 1 double spiralled hose to connect to helm pump. Extended length: 6m (19,6')
- No. 1 double spiralled hose to connect to cylinder. Extended length: 6m (19,6')
- No. 1 utility tray

## Spare parts

- 42593V - Helm purging fitting
- 42595Z - Fittings replacement kit

## Optional components

- KBE1 No. 1 double spiralled hose to connect to cylinder 15 m (49') extension )
- KBD2 No. 1 kit for double cylinder systems filling and purge
- KH94 Connection kit for UC94-OBF cylinders with old bleeders (not fast connect)
- KH128 Connection kit for cylinders (except UC95) with old bleeders (not fast connect)



# Zero Torque Feedback Tiller steering systems

Today's four stroke outboard engines are generating high torque loads which can make tiller steered boats difficult to steer. The Uflex® ZTF Tiller systems eliminate propeller torque at the tiller handle when the driver is not actively changing direction.

Using a patented hydraulic valve, the propeller torque is locked from reaching the tiller handle unless the driver pushes or pulls on the end of the handle, at which point the valve opens and allows for active steering movements.

Now you can drive your tiller steered boat in comfort, saving your energy for reeling in fish rather than effort to just get to your favorite fishing spot.

## How the ZTF tiller system works

Push on the end of the tiller handle and the valve opens allowing you to steer.

Pull on the end of the tiller handle and the valve opens allowing you to steer.

Rest your hand on the tiller and the valve remains closed, locking out the propeller torque and providing comfortable boat operation.

**WARNING!** This system is not intended to be used in place of the boat operator. Operator must maintain contact with the Tiller Handle during operation.

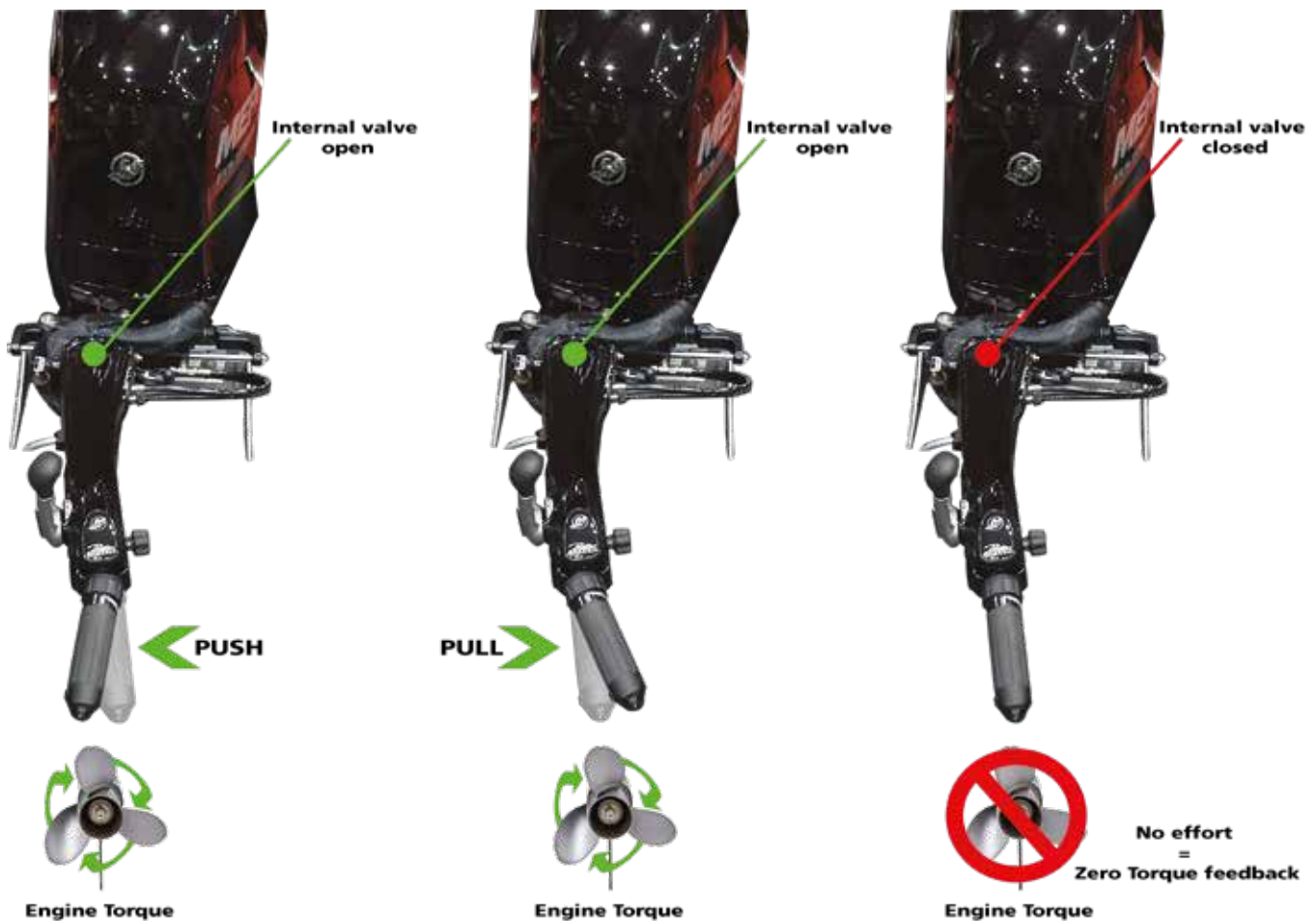

## Zero Torque Feedback Tiller steering systems

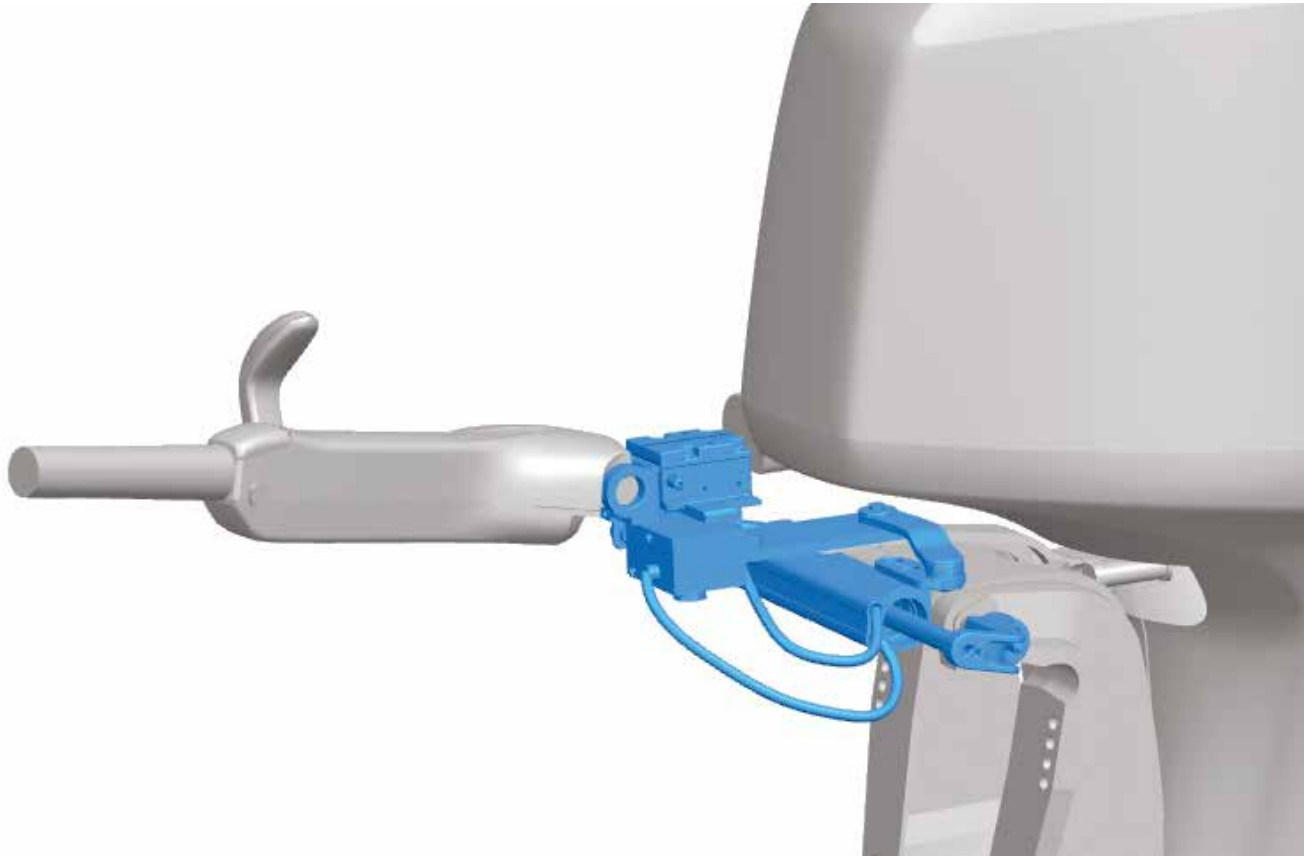

### Zero torque feedback tiller steering systems - components

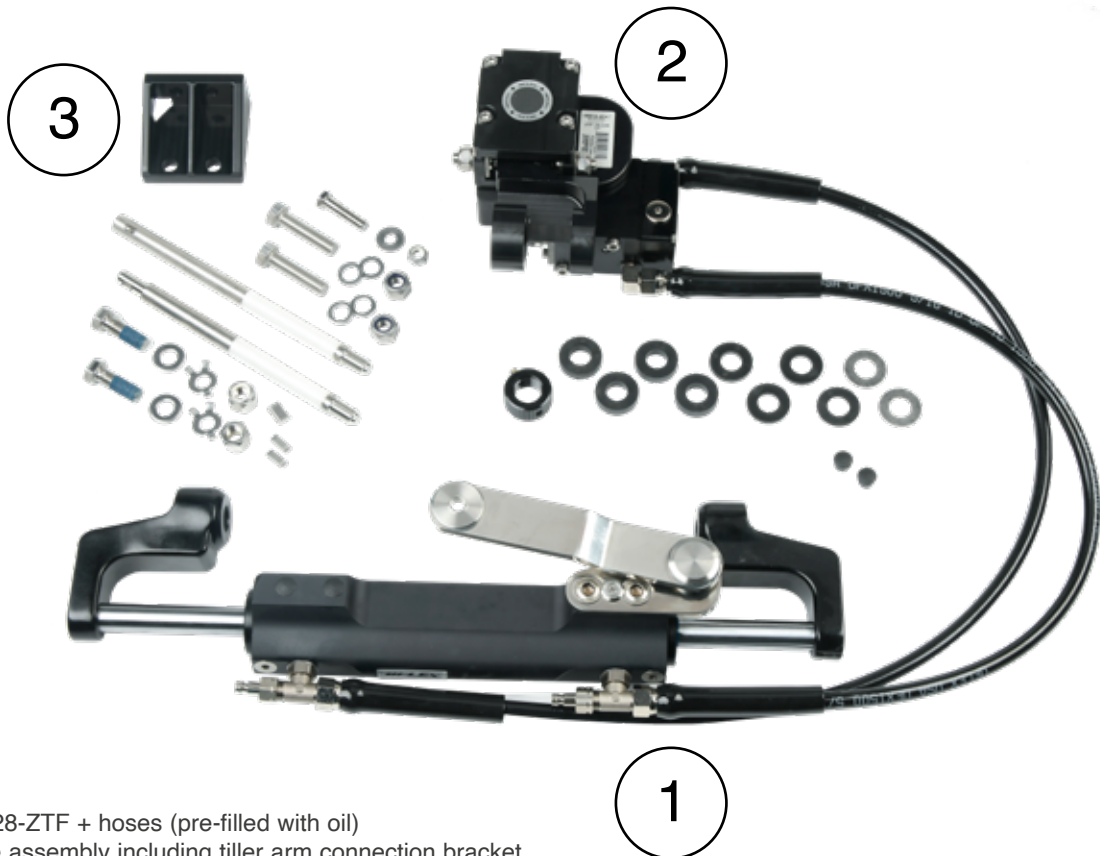

- 1- UC128-ZTF + hoses (pre-filled with oil)
- 2- Valve assembly including tiller arm connection bracket
- 3 -Example of engine connection bracket

- 2 Uflex® push-pull cables for throttle and shift

# Zero Torque Feedback Tiller steering systems

## MERCURY® Zero Torque Feedback tiller steering system

### Tiller 40-115 Mercury®

- Rated up to 115 hp
- Easy steering
- Reduced operator fatigue

**Note:** Mercury® Tiller Arm not included



**ZTF Tiller M2** 43880D For use with 75 hp to 115 hp EFI 4 stroke, from 2014 to date

## YAMAHA® Zero Torque Feedback tiller steering system

- Rated up to 200 hp Four Stroke
- Easy steering
- Reduced operator fatigue

**Note:** Yamaha® Tiller Arm not included



**ZTF Tiller Y1** 43877R For use with Yamaha® 90 hp - 115 hp - 130 hp - 2015 to date

**ZTF Tiller Y2** 43878T For use with Yamaha® 150 hp - 175 hp - 200 hp

## SUZUKI® Zero Torque Feedback tiller steering system

- Rated up to 200 hp Four Stroke
- Easy steering
- Reduced operator fatigue

**Note:** Suzuki® Tiller Arm not included



**ZTF Tiller S2** 43879V For use with Suzuki® DF150A - DF175A - DF200A







**Integra™ EPS**  
Outboard electronic power steering systems

# INTEGRA EPS

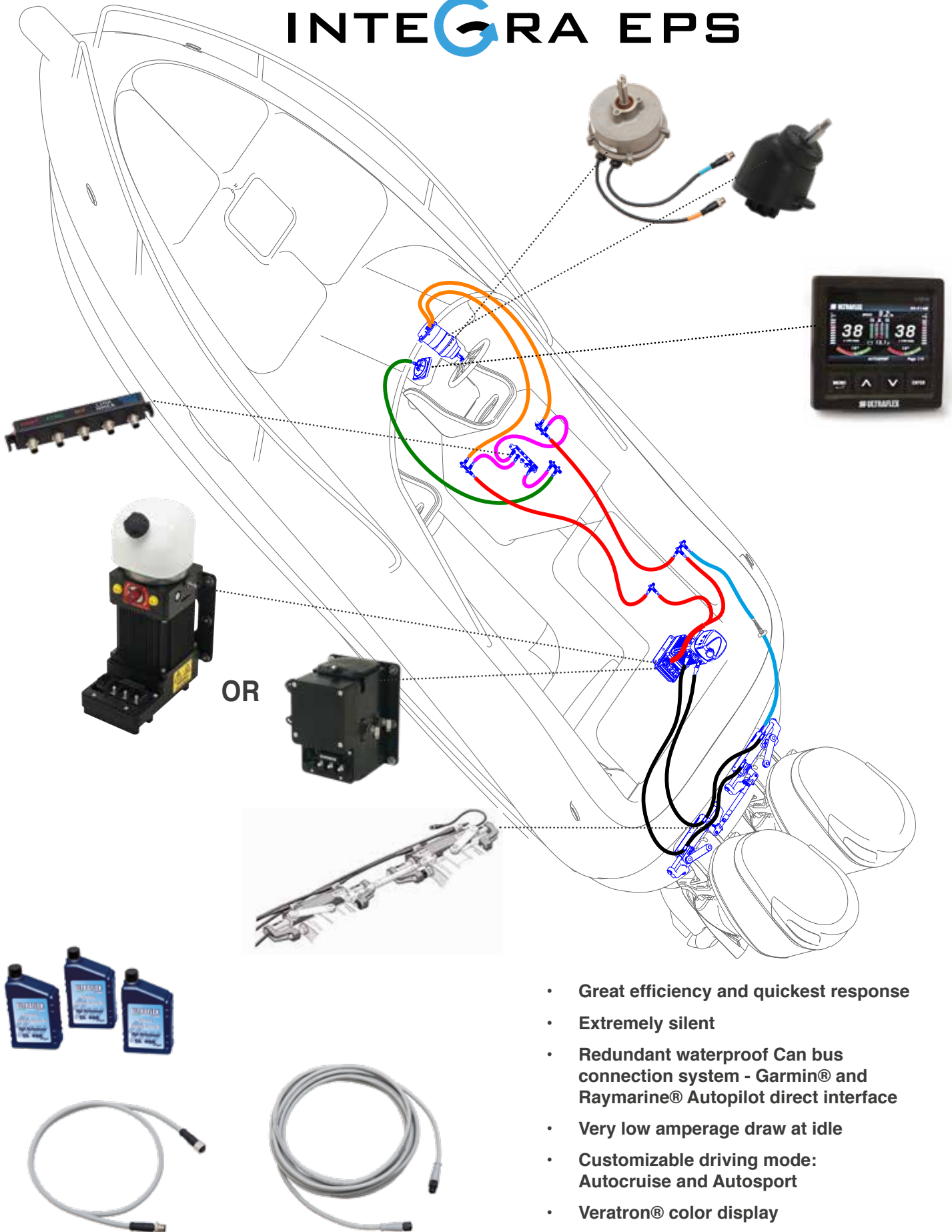

- Great efficiency and quickest response
- Extremely silent
- Redundant waterproof Can bus connection system - Garmin® and Raymarine® Autopilot direct interface
- Very low amperage draw at idle
- Customizable driving mode: Autocruise and Autosport
- Veratron® color display
- Easy installation (simplified configuration)

# INTEGRA JS

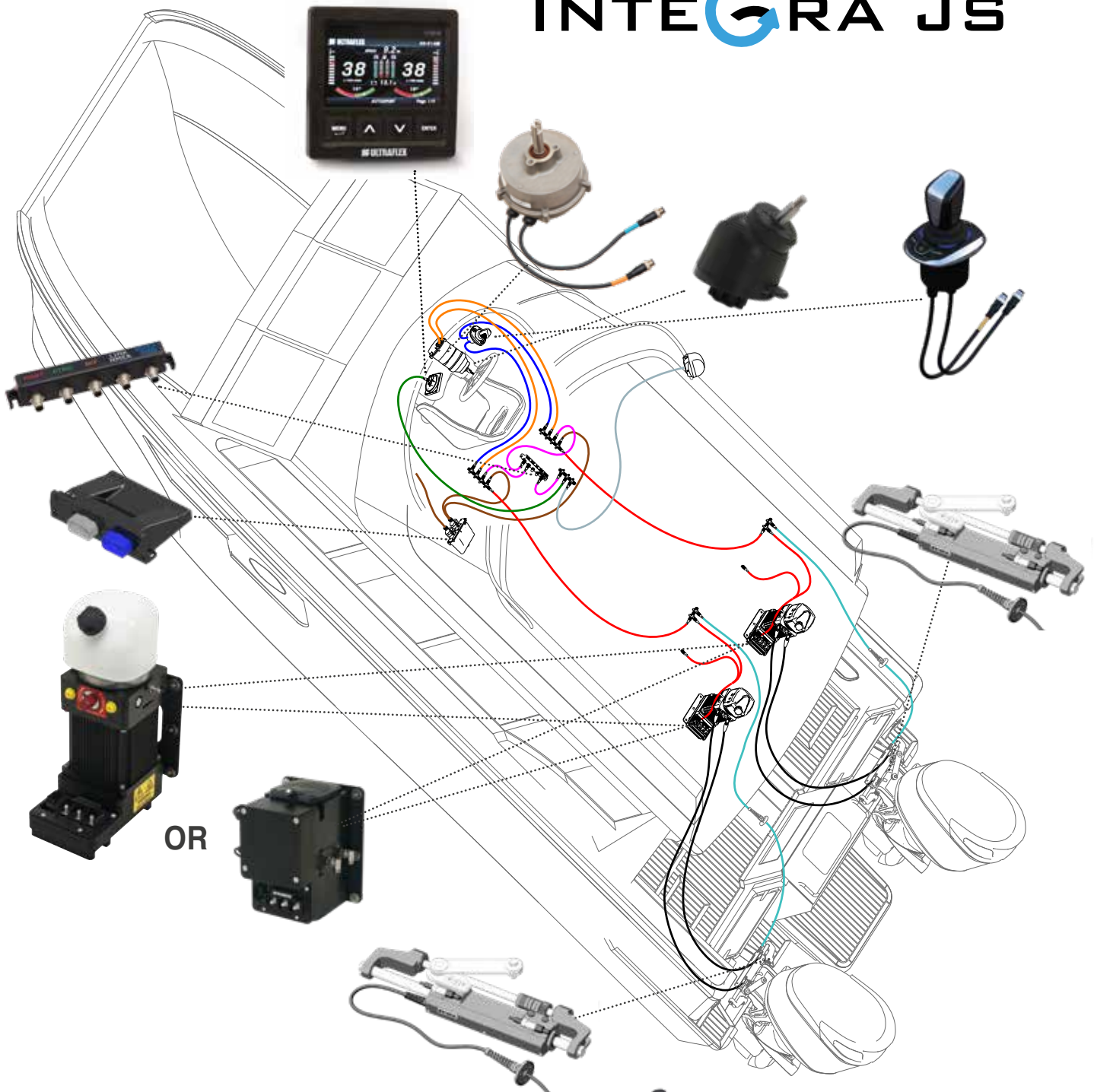

- Integra JS adds to Integra EPS functionalities a new level of manoeuvrability, thanks to the Joystick technology.
- Integra JS is a more intuitive way of driving. Designed for low speed manoeuvring the joystick grants precision and driving comfort and facilitates docking and trailer procedures as the boat can move sideways, diagonally or spin on its own axis
- Includes Boost, Heading, Anchor, Mainstay and Trim function



# Integra™

## Outboard electronic power steering systems

Model	UIP	UIPC
Operating voltage	10,8 V - 14,4 V	
Average current draw	5 A	2 A
Temperature range	-25°C / +77°C	
Nominal voltage	12 VDC	
Max flow	4,8 l/min @ 60 bar (cw & ccw)	4,0 l/min @ 50 bar
Relief valve	120 bar - 1740 PSI	105 bar - 1500 PSI
Pump unit motor	12 VDC Brushless	
Outboard engine installations	Single, dual, triple or quad	
N. of engines per motor pump unit	up to 4	up to 2
Autopilot direct interface	Garmin® Raymarine® Furuno® Simrad®	
Customizable Driving mode	Autocruise and Autosport	
Customizable wheel effort	Yes	
Exceeds Safety Standards	ISO 25197, ISO 10592, ABYC P21, P24, P27	
Ignition Protected SAE J1171	Yes	

System components	Integra EPS™	Integra JS™
UIH - Tilt mount electronic helm	✓	✓
UJS - Integra JS joystick	-	✓
UGW-D - Digital Integra JS Gateway	-	✓
UGW-A - Analogic Integra JS Gateway	-	✓
X82 - Adjustable steering wheel tilt mechanism	✓	✓
UID - Veratron®-VDO® color display	✓	✓
BCM - Body Control Module – CAN Bus network module	✓	✓
UIP - High Power electro-hydraulic power unit	✓	✓
UIPC - Compact electro-hydraulic power unit	✓	✓
UC120E - Heavy duty starboard cylinder with integrated sensor	✓	✓
UC120EP - Heavy duty port cylinder with integrated sensor	✓	✓
UC120 - Heavy duty starboard hydraulic cylinder for multiple engine applications with tie bar	✓	✓
UC120P - Heavy duty port hydraulic cylinder for multiple engine applications with tie bar	✓	✓
Tie bar - Please refer to Integra tie bar section	✓	✓
KIT OB-SVS - High pressure Hydraulic hoses with pre crimped fittings	✓	✓
CAN Bus wires - Can Bus power wires	✓	✓
KBD3 - Purging kit with twin spiralled hoses and connectors (optional)	✓	✓
OL460 - 3 one litre hydraulic oil bottles (single bottle - 436467V)	✓	✓

## Integra EPS and Integra JS key benefits

- **Redundant electronic steering system**, a reliable way to reduce steering effort, tuning your driving and enhancing steering experience.
- **Powerful output, great efficiency and quickest response** in any situation, thanks to the brushless motor of the pump unit and to the electronic management
- **Extremely silent**
- **Low amperage system**
- **Veratron® colour display**
- **Customizable driving mode:** the user can choose between Autocruise and Autosport driving mode
- **Autopilot direct interface:** **Garmin®** Reactor™ 40 Steer-by-wire, **Raymarine®** EV-2 SBW, **Furuno®** Navipilot 300, **Simrad®** AP44 e Ap48 con NAC-D
- **Easy installation**, thanks to the simplified configuration and the CAN bus connection system.
- **Customizable wheel effort.**
- Wheel effort is programmed to change with engine RPM.
- **Tilt range of 48° and 5 locking positions**, thanks to the **X82** tilt mechanisms
- **Easy boat handling**, thanks to the adjustable speed sensitive turns lock to lock
- **The pump unit** is available in **2 versions** to choose from, based on the selected application: **UIP** (High Power electro-hydraulic power unit) and **UIPC** (Compact electro-hydraulic power unit) and **can be positioned anywhere** on the boat
- It's possible to have a no tie-bar configuration, using two motor pump units
- **Automatic Power Selector** to ensure optimal voltage
- Designed for single, dual, triple or quad outboard engines
- Available for multiple steering stations applications
- It can handle up to 4 engines with a single power unit
- Heavy duty steering cylinder with embedded CAN bus position sensor

## Integra JS additional functionalities

- **Integra JS** adds to Integra EPS functionalities a new level of manoeuvrability, thanks to the **Joystick technology**
- **Integra JS** is a more **intuitive way of driving**. Designed for **low speed manoeuvring**, the Joystick grants precision and driving comfort and **facilitates docking and trailer procedures** as the boat can move sideways, diagonally or spin on its own axis
- **Integra JS Joystick** includes several functions: **Boost** function used to momentarily increase engine rpm if you need instant thrust, **Trim** function for adjusting motor feet, **Heading** function, that gives the ability to maintain the set course, **Anchor** function, to maintain boat position via GPS connection and **MainStay** the combination of the previous functions (**Heading** and **Anchor**). **Anchor, Heading and MainStay** functions needs the presence of **Veratron® Nav Sensor - 20201Z**





# Integra™

## Outboard electronic power steering systems

### UIH1 - Electronic helm

- Electronic steering helm tilt mount **X82** -43817N
- Easy to install, no oil or hydraulic hoses

**UIH1** - 43536M - first station electronic helm.

**UIH2** - 43537P - second station electronic helm

**UIH3** - 43538S - third station electronic helm

- Resistant to harsh marine conditions
- Steering wheel turns can be set by the user.
- Variable steering wheel resistance according to boat speed
- Instant responsiveness
- Redundant architecture with 2 CAN bus channels



**X82**



**UIH1**

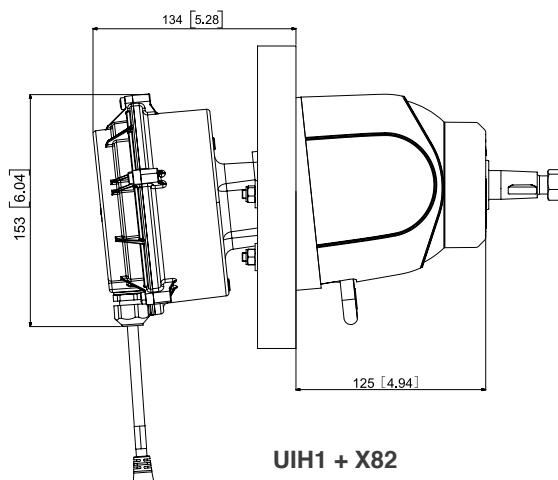
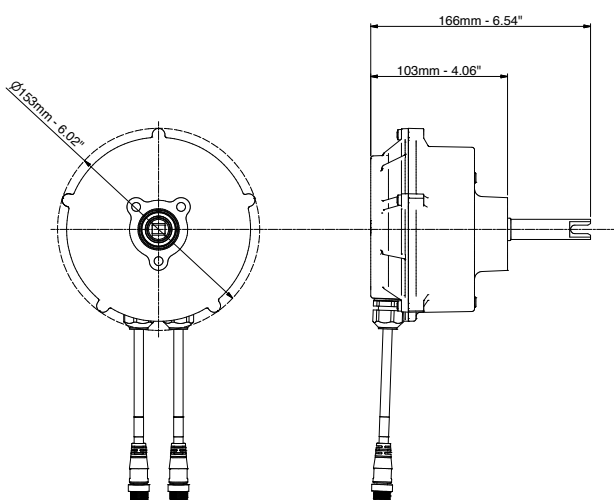

**UIH1 + X82**

## UJS Integra JS joystick

- Power: turning on the station
- BOOST switch on the handle: momentarily increases engine rpm if you need instant thrust, it is active as long as the switch is pressed
- Signal lights: indicate if the joystick is in Neutral or the set direction
- **Heading**: ability to maintain the set course
- UP and Down trim keys: to be connected to the boat's trims
- **Anchor** function allows boat position to be maintained via GPS connection
- **MainStay** function is activated by pressing the **Heading** and **Anchor** keys
- Anchor, Heading and MainStay function requires Veratron® Nav Sensor - part number 20201Z
- CAN Bus communication via 2 DeviceNet® connectors.



UJS1	43922T	Integra JS joystick first station
UJS2	44078N	Integra JS joystick second station

## UJS - B Integra JS joystick with Bow Thruster

- Power: turning on the station
- BOOST switch on the handle: momentarily increases engine rpm if you need instant thrust, it is active as long as the switch is pressed
- Signal lights: indicate if the joystick is in Neutral or the set direction
- **Thruster only**: operate bow thruster only
- **Heading**: ability to maintain the set course
- UP and Down trim keys: to be connected to the boat's trims
- **Anchor** function allows boat position to be maintained via GPS connection
- **MainStay** function is activated by pressing the **Heading** and **Anchor** keys
- Anchor, Heading and MainStay function requires Veratron® Nav Sensor - part number 20201Z
- CAN Bus communication via 2 DeviceNet® connectors.

new



UJS-B1	44162B	Integra JS joystick first station with Bow Thruster
UJS-B2	44163D	Integra JS joystick second station with Bow Thruster

## BCM (Body Control Module) - Can Bus Network Module

- Waterproof CAN bus connection system
- Direct interface with Garmin®, Raymarine®, Simrad® and Furuno® autopilot
- Very compact dimensions



BCM	43540C	Can Bus network module
-----	--------	------------------------

BCM



# Integra™

## Outboard electronic power steering systems

### UGW- Gateway

Device to control throttle and inverter in Honda, Suzuki and Selva outboard engines. It allows management of the trims directly from the joystick.

#### UGW- D Digital Gateway

UGW-D	43934A	Digital Gateway
UGWD-S1	43991N	Harness for UGW-D digital gateway and Suzuki engines equippe with SPC1
UGWD-S2	43990L	Harness for UGW-D digital gateway and Suzuki engines equippe with SPC2
UGWD-H1	43990L	Harness for UGW-D digital gateway and Honda engines

#### UGW- A Analogic Gateway

UGW-A	43985U	Analog Gateway
UGWA-H2	44083F	Harness for UGW-A analog gateway and Honda engines



UGW

### UID - Veratron® color display

- Veratron® **color Display** - user adjustable brightness
- **Customizable driving mode:** the user can choose between **Autocruise** and **Autosport** driving mode
- **Customizable wheel effort.**
- **Automatic wheel effort setting** with engine RPM
- Multiple steering station applications
- Electronic anchor response level setting

UID - B	43539U	UID Veratron® display - black
UID - W	43825V	UID Veratron® display - white



UID

#### Display visual information:

- Boat speed
- Engine RPM
- Engine temperature
- Rudder angle display
- Trim angle display
- Fuel level
- Battery voltage
- Percentage operation bow thruster



## UIP and UIPC - Power units

- 12 VDC brushless motor
- High power: very short lead times for maximum reactivity
- Embedded automatic power selector to manage the power supply from 2 batteries
- Can be installed anywhere on the boat
- 90° swiveling fittings for easy hose connection
- Tank: 1 litre (0.26 gal) UIP power unit; 0,3 litres (0.08 gal) UIPC power unit
- Vented cap
- Marine anodized aluminum body
- Include the main connector with 1m communication cables
- Ignition Protected SAE J1171



UIPC



UIP

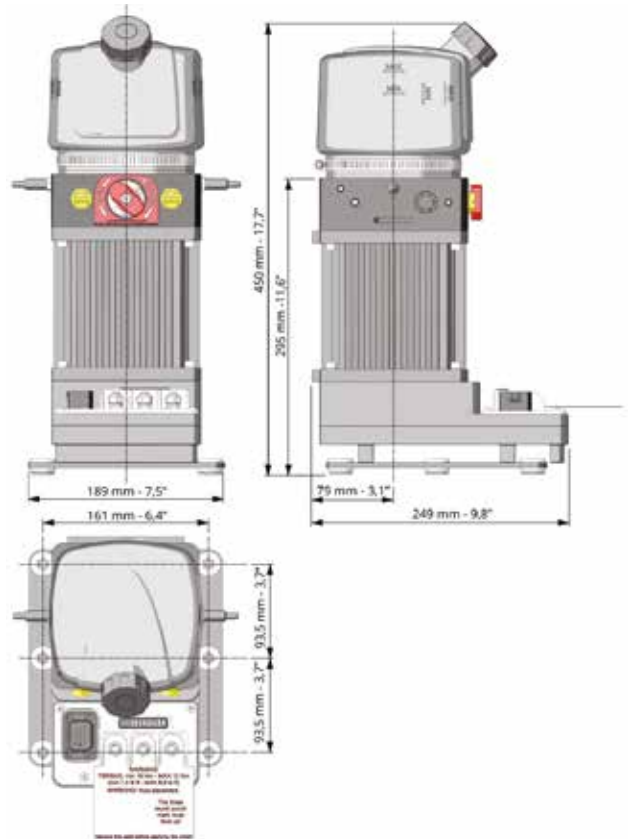
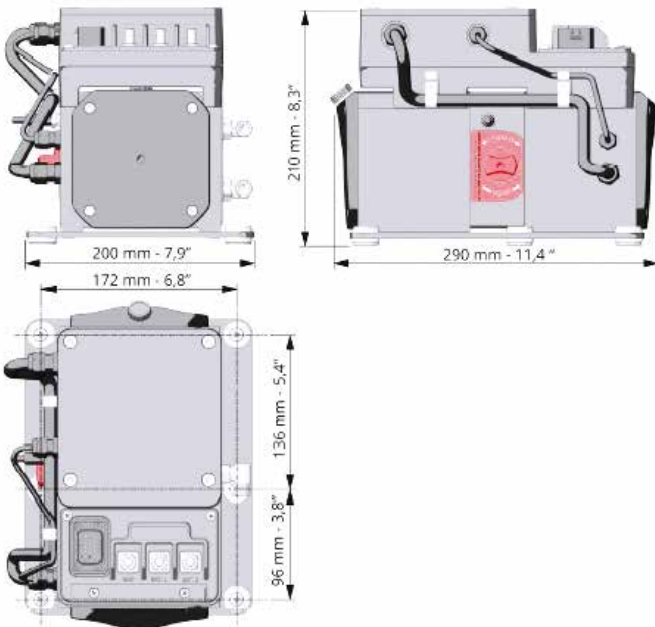

UIP	43541E	High Power Power unit
UIPC	43859N	Compact power unit

# Integra™

## Outboard electronic power steering systems

### UC120E and UC120EP Cylinders

CE



UC120E



UC120EP

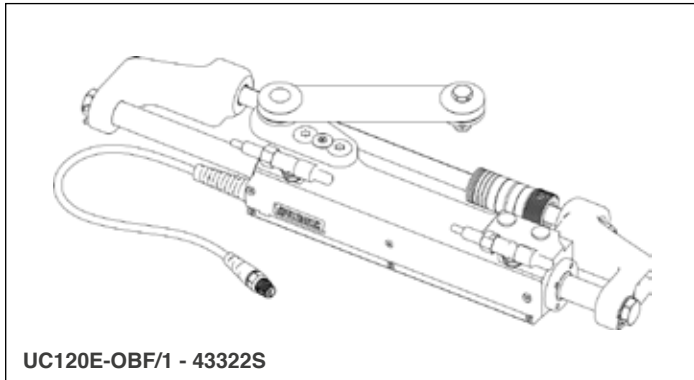

UC120E-OBF/1 - 43322S

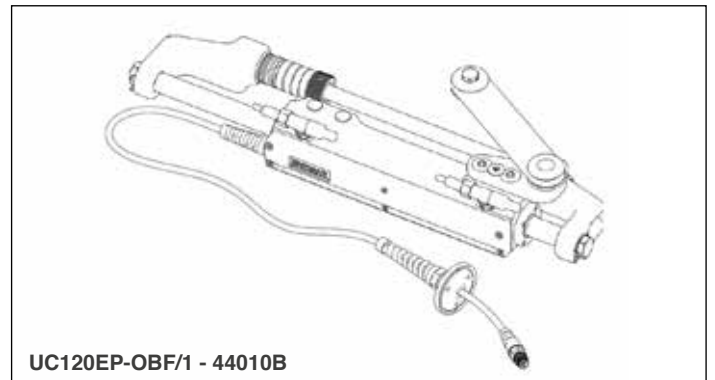

UC120EP-OBF/1 - 44010B

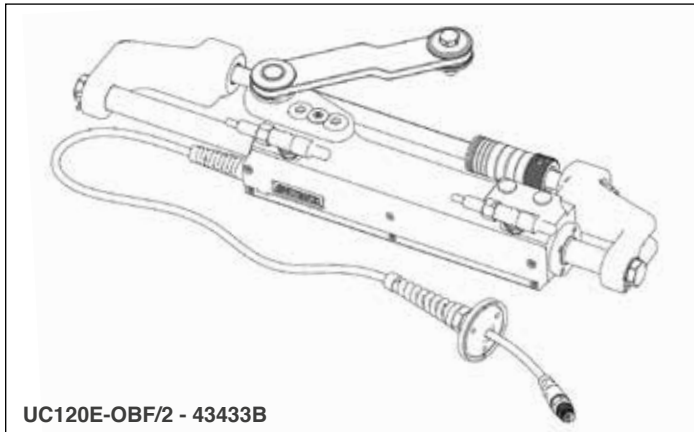

UC120E-OBF/2 - 43433B

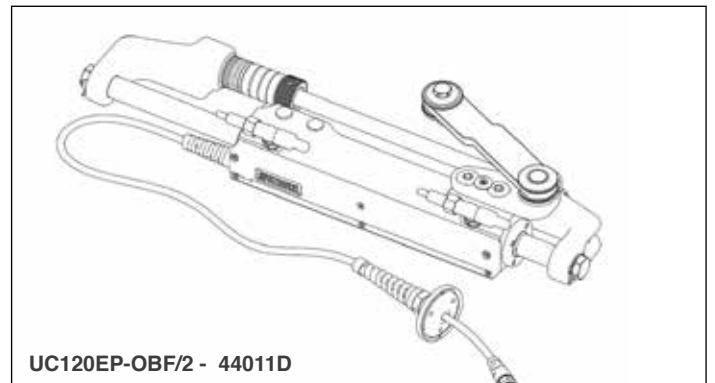

UC120EP-OBF/2 - 44011D

- **UC120E:** heavy-duty starboard cylinder with integrated sensor
- **UC120EP:** heavy-duty port cylinder with integrated sensor

Volume	120 cc - 7.5 cu. in
Output force	800 kg - 1764 lbs
Internal diameter	36.5 mm - 1.44"
Stroke	184 mm - 7.24"
Oil	OL460

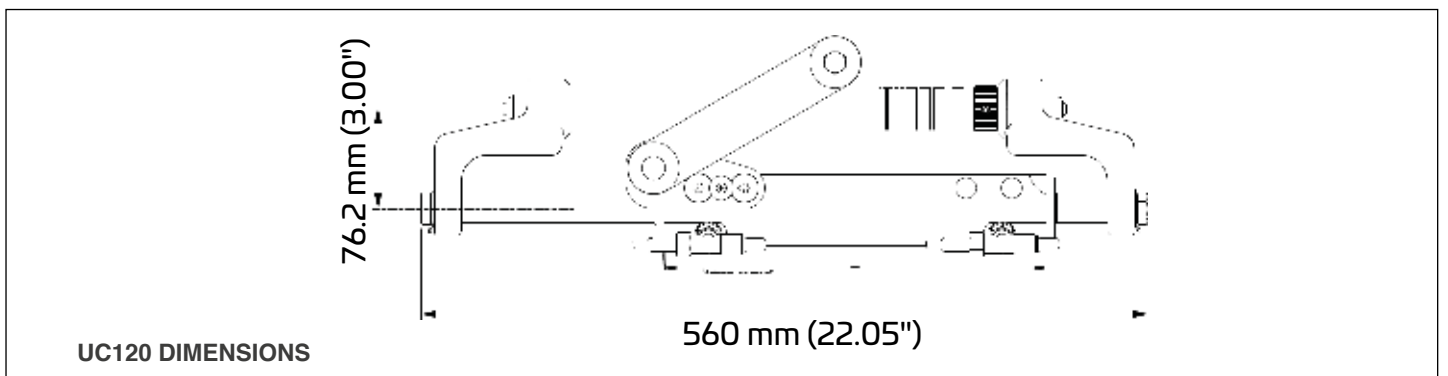

UC120 DIMENSIONS

560 mm (22.05")

# Integra™

## Outboard electronic power steering systems

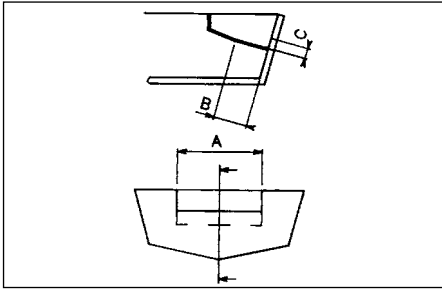

SPLASHWELL DIMENSION REQUIREMENTS			
Engine No.	A	B	C
1	560 mm - 22.05"	152 mm - 5.98"	152 mm - 5.98"
2	1110 mm - 43.70"	152 mm - 5.98"	152 mm - 5.98"

### UC120E and UC120EP Cylinder application

ENGINE	MODEL	YEAR	CYLINDER STARBOARD	P. No.	CYLINDER PORT	P. No.
Mercury® Mariner®	115-125-150 EFI 2S	1990-2007	UC120E-OBF/1	43322S	UC120EP-OBF/1	44010B
	225-250 EFI 2S	2000-2007	UC120E-OBF/1	43322S	UC120EP-OBF/1	44010B
	135-150-175 OPTIMAX	1999-2018	UC120E-OBF/1	43322S	UC120EP-OBF/1	44010B
	200-225-250 OPTIMAX	1999-2018	UC120E-OBF/1	43322S	UC120EP-OBF/1	44010B
	RACING 300 OPTIMAX	1999-2011	UC120E-OBF/1	43322S	UC120EP-OBF/1	44010B
	250 SALTWATER EFI 4S	2007-2011	UC120E-OBF/1	43322S	UC120EP-OBF/1	44010B
	135-150-175-200 VERADO L4	2004-2012	UC120E-OBF/1	43322S	UC120EP-OBF/1	44010B
	FOURSTROKE 175-200 V6	2018-to date	UC120E-OBF/1	43322S	UC120EP-OBF/1	44010B
	FOURSTROKE 225-300 V8	2018-to date	UC120E-OBF/1	43322S	UC120EP-OBF/1	44010B
	Evinrude®	E115-E130-E135 2S V4	1995-to date	UC120E-OBF/2	43433B	UC120EP-OBF/2
E150-E175-E200-E225-E250-E300 2S V6		1995-to date	UC120E-OBF/2	43433B	UC120EP-OBF/2	44011D
Yamaha®	150F-200F-250G 2S	1990-2008	UC120E-OBF/2	43433B	UC120EP-OBF/2	44011D
	150 HPDI VMAX 2S	1996-2007	UC120E-OBF/2	43433B	UC120EP-OBF/2	44011D
	175-200-225-250-300 HPDI VMAX 2S	2000-2008	UC120E-OBF/2	43433B	UC120EP-OBF/2	44011D
	F115-F150 EFI 4S	2000-2008	UC120E-OBF/1	43322S	UC120EP-OBF/1	44010B
	F200-F225-F250 4S	1999-2007	UC120E-OBF/2	43433B	UC120EP-OBF/2	44011D
	F115-F150-F175-F200 L4	2002-2007	UC120E-OBF/1	43322S	UC120EP-OBF/1	44010B
	F200-F225-F250-F300 V6 4S	2004-to date	UC120E-OBF/2	43433B	UC120EP-OBF/2	44011D
	F350 4S V8	2006-to date	UC120E-OBF/1	43322S	UC120EP-OBF/1	44010B
Honda®	BF135-BF150 4S	2005-to date	UC120E-OBF/1	43322S	UC120EP-OBF/1	44010B
	BF150 V-TEC 4S	2008-to date	UC120E-OBF/1	43322S	UC120EP-OBF/1	44010B
	BF175-BF200-BF225- BF250 4S	2001-to date	UC120E-OBF/1	43322S	UC120EP-OBF/1	44010B
Suzuki®	DF100-115-140 4S	2008-to date	UC120E-OBF/1	43322S	UC120EP-OBF/1	44010B
	DF150-175-DF200 L4 4S	2006-to date	UC120E-OBF/1	43322S	UC120EP-OBF/1	44010B
	DF200-DF225-DF250-DF300-DF350 V6 4S	2004-to date	UC120E-OBF/2	43433B	UC120EP-OBF/2	44011D
Tohatsu®	115-120-140 2S	2004-to date	UC120E-OBF/2	43433B	UC120EP-OBF/2	44011D
	70-90-115 TLDI 4S	2004-to date	UC120E-OBF/1	43322S	UC120EP-OBF/1	44010B
	BFT 115-150-200-225-250 4S	2014-to date	UC120E-OBF/1	43322S	UC120EP-OBF/1	44010B
	BFT60-75-90	2015-to date	UC120E-OBF/1	43322S	UC120EP-OBF/1	44010B
Selva®	80 PORTOFINO/TIGERSHARK 2S	1995-2008	UC120E-OBF/1	43322S	UC120EP-OBF/1	44010B
	150 WHITE SHARK 2S	2001-2007	UC120E-OBF/2	43433B	UC120EP-OBF/2	44011D
	100EFI MARLIN -115 EFI NARWHAL	2000-to date	UC120E-OBF/1	43322S	UC120EP-OBF/1	44010B
	225 BEAKED WHALE 4S	2019-to date	UC120E-OBF/2	43433B	UC120EP-OBF/2	44011D
	150EFI KILLER WHALE 4S - 200 SEI WHALE 4S	2000-to date	UC120E-OBF/1	43322S	UC120EP-OBF/1	44010B
Johnson®	BJ90-115-140 4S	2001-2007	UC120E-OBF/1	43322S	UC120EP-OBF/1	44010B
	J90-115 V4 2S	1995-2007	UC120E-OBF/2	43433B	UC120EP-OBF/2	44011D
	J150-175 V6 2S	1995-2007	UC120E-OBF/2	43433B	UC120EP-OBF/2	44011D
	J200-225 V6 4S	2004-2007	UC120E-OBF/2	43433B	UC120EP-OBF/2	44011D
OXE®	125-150-175-200HP DIESEL	2018-to date	UC120E-OBF/1	43322S	UC120EP-OBF/1	44010B
	300 HP DIESEL	2020-to date	UC120E-OBF/1	43322S	UC120EP-OBF/1	44010B
COX®	300 HP	2020-to date	UC120E-OBF/2	43433B	UC120EP-OBF/2	44011D

# Integra™

## Outboard electronic power steering systems

UC120 an UC120P Hydraulic cylinders

CE



UC120



UC120P

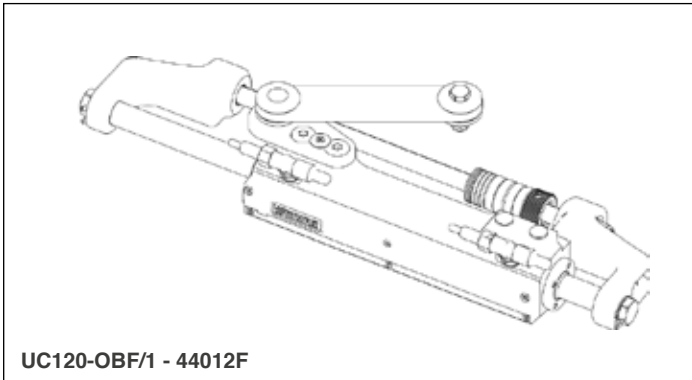

UC120-OBF/1 - 44012F

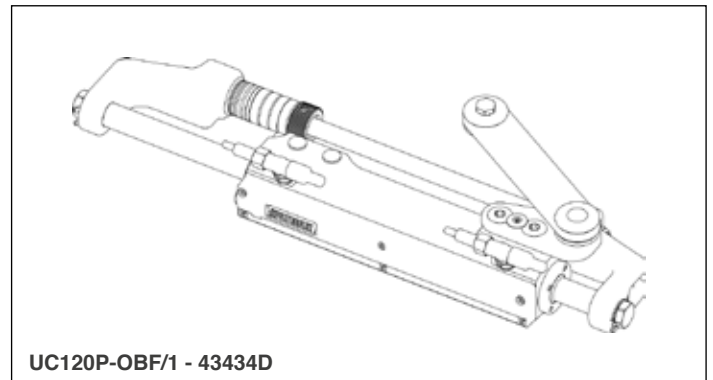

UC120P-OBF/1 - 43434D

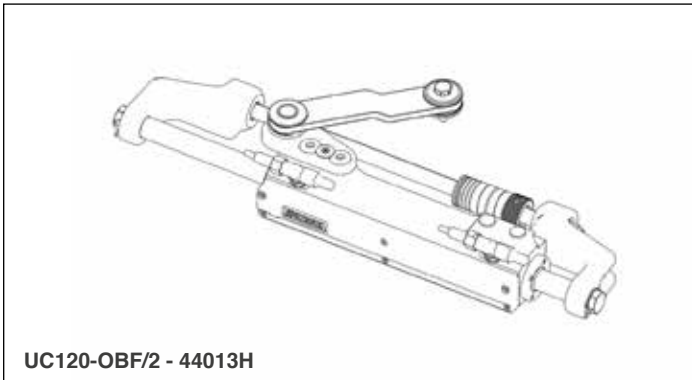

UC120-OBF/2 - 44013H

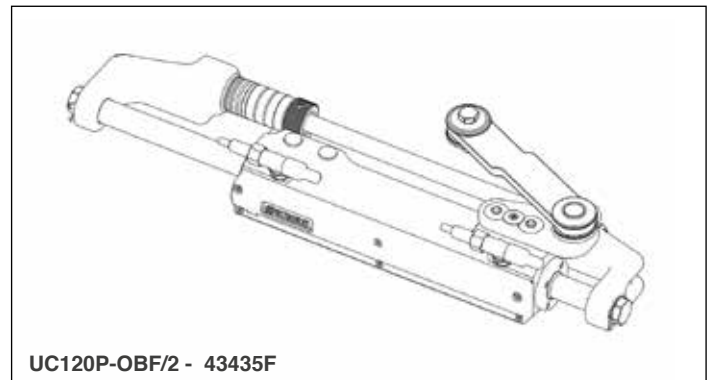

UC120P-OBF/2 - 43435F

- **UC120:** heavy-duty starboard cylinder for two, three or four outboard engine applications with tie bar
- **UC120P:** heavy-duty port cylinder for two, three or four outboard engine applications with tie bar

Volume	120 cc - 7.5 cu. in
Output force	800 kg - 1764 lbs
Internal diameter	36.5 mm - 1.44"
Stroke	184 mm - 7.24"
Oil	OL460

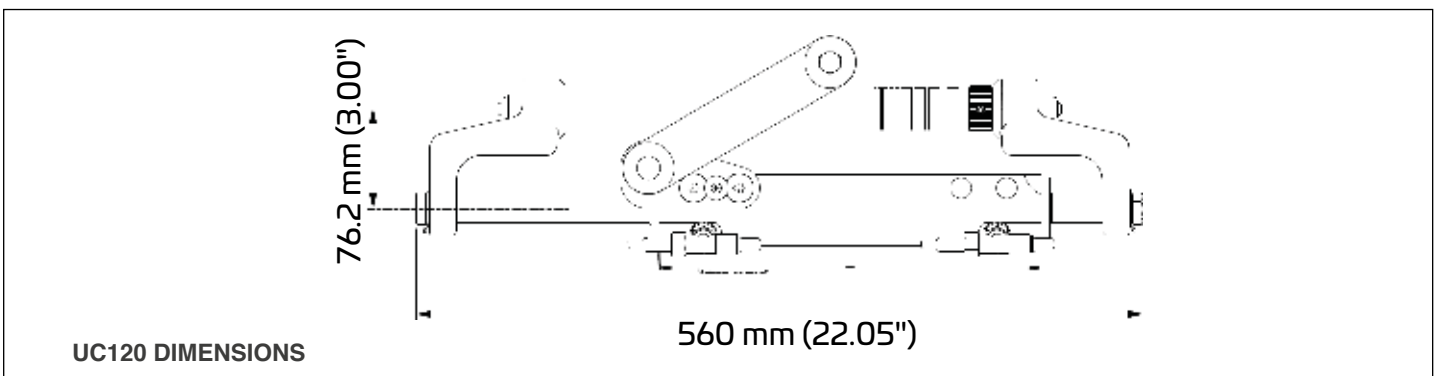

UC120 DIMENSIONS



# Integra™

## Outboard electronic power steering systems

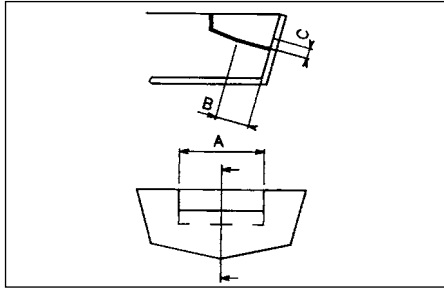

SPLASHWELL DIMENSION REQUIREMENTS			
Engine No.	A	B	C
1	560 mm - 22.05"	152 mm - 5.98"	152 mm - 5.98"
2	1110 mm - 43.70"	152 mm - 5.98"	152 mm - 5.98"

### UC120 Cylinder applications

ENGINE	MODEL	YEAR	CYLINDER	P. No.		
Mercury® Mariner®	115-125-150 EFI 2S	1990-2007	UC120-OBF/1	44012F	UC120P-OBF/1	43434D
	225-250 EFI 2S	2000-2007	UC120-OBF/1	44012F	UC120P-OBF/1	43434D
	135-150-175 OPTIMAX	1999-2018	UC120-OBF/1	44012F	UC120P-OBF/1	43434D
	200-225-250 OPTIMAX	1999-2018	UC120-OBF/1	44012F	UC120P-OBF/1	43434D
	RACING 300 OPTIMAX	1999-2011	UC120-OBF/1	44012F	UC120P-OBF/1	43434D
	250 SALTWATER EFI 4S	2007-2011	UC120-OBF/1	44012F	UC120P-OBF/1	43434D
	135-150-175-200 VERADO L4	2004-2012	UC120-OBF/1	44012F	UC120P-OBF/1	43434D
	FOURSTROKE 175-200 V6	2018-to date	UC120-OBF/1	44012F	UC120P-OBF/1	43434D
	FOURSTROKE 225-300 V8	2018-to date	UC120-OBF/1	44012F	UC120P-OBF/1	43434D
Evinrude®	E115-E130-E135 2S V4	1995-to date	UC120-OBF/2	44013H	UC120P-OBF/2	43435F
	E150-E175-E200-E225-E250-E300 2S V6	1995-to date	UC120-OBF/2	44013H	UC120P-OBF/2	43435F
Yamaha®	150F-200F-250G 2S	1990-2008	UC120-OBF/2	44013H	UC120P-OBF/2	43435F
	150 HPDI VMAX 2S	1996-2007	UC120-OBF/2	44013H	UC120P-OBF/2	43435F
	175-200-225-250-300 HPDI VMAX 2S	2000-2008	UC120-OBF/2	44013H	UC120P-OBF/2	43435F
	F115-F150 EFI 4S	2000-2008	UC120-OBF/1	44012F	UC120P-OBF/1	43434D
	F200-F225-F250 4S	1999-2007	UC120-OBF/2	44013H	UC120P-OBF/2	43435F
	F115-F150-F175-F200 L4	2002-2007	UC120-OBF/1	44012F	UC120P-OBF/1	43434D
	F200-F225-F250-F300 V6 4S	2004-to date	UC120-OBF/2	44013H	UC120P-OBF/2	43435F
F350 4S V8	2006-to date	UC120-OBF/1	44012F	UC120P-OBF/1	43434D	
Honda®	BF135-BF150 4S	2005-to date	UC120-OBF/1	44012F	UC120P-OBF/1	43434D
	BF150 V-TEC 4S	2008-to date	UC120-OBF/1	44012F	UC120P-OBF/1	43434D
	BF175-BF200-BF225- BF250 4S	2001-to date	UC120-OBF/1	44012F	UC120P-OBF/1	43434D
Suzuki®	DF100-115-140 4S	2008-to date	UC120-OBF/1	44012F	UC120P-OBF/1	43434D
	DF150-175-DF200 L4 4S	2006-to date	UC120-OBF/1	44012F	UC120P-OBF/1	43434D
	DF200-DF225-DF250-DF300-DF350 V6 4S	2004-to date	UC120-OBF/2	44013H	UC120P-OBF/2	43435F
Tohatsu®	115-120-140 2S	2004-to date	UC120-OBF/2	44013H	UC120P-OBF/2	43435F
	70-90-115 TLDI 4S	2004-to date	UC120-OBF/1	43322S	UC120P-OBF/1	43434D
	BFT 115-150-200-225-250 4S	2014-to date	UC120-OBF/1	44012F	UC120P-OBF/1	43434D
	BFT60-75-90	2015-to date	UC120-OBF/1	44012F	UC120P-OBF/1	43434D
Selva®	80 PORTOFINO/TIGERSHARK 2S	1995-2008	UC120-OBF/1	44012F	UC120P-OBF/1	43434D
	150 WHITE SHARK 2S	2001-2007	UC120-OBF/2	44013H	UC120P-OBF/2	43435F
	100EFI MARLIN -115 EFI NARWHAL	2000-to date	UC120-OBF/1	44012F	UC120P-OBF/1	43434D
	225 BEAKED WHALE 4S	2019-to date	UC120-OBF/2	44013H	UC120P-OBF/2	43435F
	150EFI KILLER WHALE 4S - 200 SEI WHALE 4S	2000-to date	UC120-OBF/1	44012F	UC120P-OBF/1	43434D
Johnson®	BJ90-115-140 4S	2001-2007	UC120-OBF/1	44012F	UC120P-OBF/1	43434D
	J90-115 V4 2S	1995-2007	UC120-OBF/2	44013H	UC120P-OBF/2	43435F
	J150-175 V6 2S	1995-2007	UC120-OBF/2	44013H	UC120P-OBF/2	43435F
	J200-225 V6 4S	2004-2007	UC120-OBF/2	44013H	UC120P-OBF/2	43435F
OXE®	125-150-175-200HP DIESEL	2018-to date	UC120-OBF/1	44012F	UC120P-OBF/1	43434D
	300 HP DIESEL	2020-to date	UC120-OBF/1	44012F	UC120P-OBF/1	43434D
COX®	300 HP	2020-to date	UC120-OBF/2	44013H	UC120P-OBF/2	43435F



# Integra™ Tie bars

Tie bars suitable with INTEGRA electronic power steering systems only

## A96-120 - Tie bar for twin outboard engine/single UC120E or UC120EP cylinder

Two different lengths available:  
From 26" to 29"X engine center  
From 29" to 34.5" engine center



<b>A96 M/Y-120-29</b>	43471K	From 26" to 29" engine center - For Mercury® and Yamaha® engines
<b>A96 M/Y-120-34.5</b>	43472M	From 29" to 34.5" engine center - For Mercury® and Yamaha® engines
<b>A96 S/H-120-29</b>	43899B	From 26" to 29" engine center - For Suzuki® and Honda® engines
<b>A96 S/H-120-34.5</b>	43900G	From 29" to 34.5" engine center - For Suzuki® and Honda® engines

## A95-120 - Tie bar for twin outboard engine/dual UC120E and UC120P or UC120EP and UC120 cylinder

Two different lengths available:  
From 26" to 32" engine center  
From 32" to 37.5" engine center



<b>A95 M/Y-120-32</b>	43437K	From 26" to 32" engine center - For Mercury® and Yamaha® engines
<b>A95 M/Y-120-37.5</b>	43468X	From 32" to 37.5" engine center - For Mercury® and Yamaha® engines
<b>A95 S/H-120-32</b>	43903N	From 26" to 32" engine center - For Suzuki® and Honda® engines
<b>A95 S/H-120-37.5</b>	43904R	From 32" to 37.5" engine center - For Suzuki® and Honda® engines

Tie bars suitable with INTEGRA electronic power steering systems only

## AS-GEN3 - 43918C - Tie bar for Suzuki AMD and BMD engines



Suitable for applications with Suzuki GEN3 engines with integrated cylinder and Silversteer, Masterdrive and Integra systems

## A97-120 - Tie bar for triple outboard engines/dual UC120E and UC120P cylinder

Two different lengths available:  
From 26" to 30" engine center  
From 30" to 35.5" engine center



**A97 S/H-120**



**A97 M/Y-120**

<b>A97 M/Y-120-30</b>	43474S	From 26" to 30" engine center - For Mercury® and Yamaha® engines
-----------------------	--------	--

<b>A97 M/Y-120-35.5</b>	43475U	From 30" to 35.5" engine center - For Mercury® and Yamaha® engines
-------------------------	--------	--

<b>A97 S/H-120-30</b>	43907X	From 26" to 30" engine center - For Suzuki® and Honda® engines
-----------------------	--------	--

<b>A97 S/H-120-35.5</b>	43908Z	From 30" to 35.5" engine center - For Suzuki® and Honda® engines
-------------------------	--------	--

## A98-120 - Tie bar for quad outboard engines/dual UC120E and UC120P cylinder

From 26" to 32" engine center



**A98 S/H-120**



**A98 M/Y-120**

<b>A98 M/Y-120</b>	43543J	From 26" to 32" engine center - For Mercury® and Yamaha® engines
--------------------	--------	--

<b>A98 S/H-120</b>	43910K	From 26" to 32" engine center - For Suzuki® and Honda® engines
--------------------	--------	--

## Integra™ Tie bars

Remote bypass valve for UIP and UIPC power units

**LTB6 - 44042R - Remote bypass valve**



**LTB6**

### **OB-2C-SVS KIT : DUAL CYLINDER/DOUBLE ENGINE CONNECTION KIT FOR INTEGRA SYSTEMS WITH COUPLING BARS**

Two high pressure Kevlar stranded flexible hoses with pre-crimped fittings and bend restrictors. Recommended for use with all UC120 Series cylinders.

Three lengths available: 70 cm (2.3'), 90 cm (2.95') and 120 cm (3.95').

KIT OB-2C-SVS	LENGTH	P. No.
KIT OB-2C-SVS-07	0,7 m - 2.30 ft	41705 Y
KIT OB-2C-SVS-09	0,9 m - 2.95 ft	41706 A
KIT OB-2C-SVS-12	1,20 m - 3.95 ft	41707 C



**KIT OB-2C-SVS**

## Single engine, single cylinder

# INTEGRA EPS

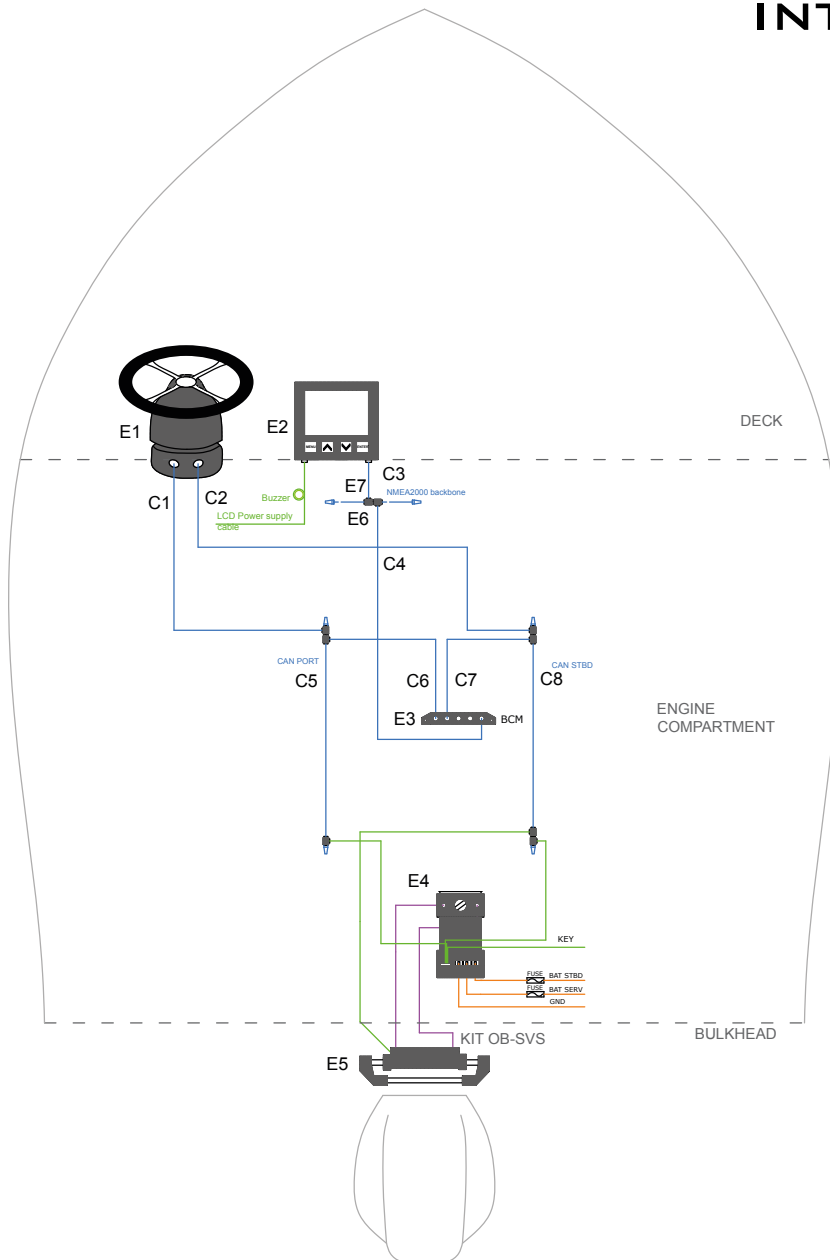

### Main components

Name	Description	Quantity
E1	UIH1 Electronic helm - 43536M	1
E1	X82 Tilt mechanism - 43187N	1
E2	Veratron display - 43539U	1
E3	BCM - Body control module - 43540C	1
E4	UIPC compact power unit - 43859N	1
E5	UC120E (or UC120EP) Cylinder with sensor included	1
E6	CAN bus - Tee connection - 43578E	9
E7	CAN bus - Terminator pair - 43576A	3
C1-C8	CAN-bus cables - length on request	8
KIT OB-SVS	Hydraulic hoses kit - length on request	1

# Integra™ EPS Applications

Dual engine, single cylinder

INTEGRA EPS

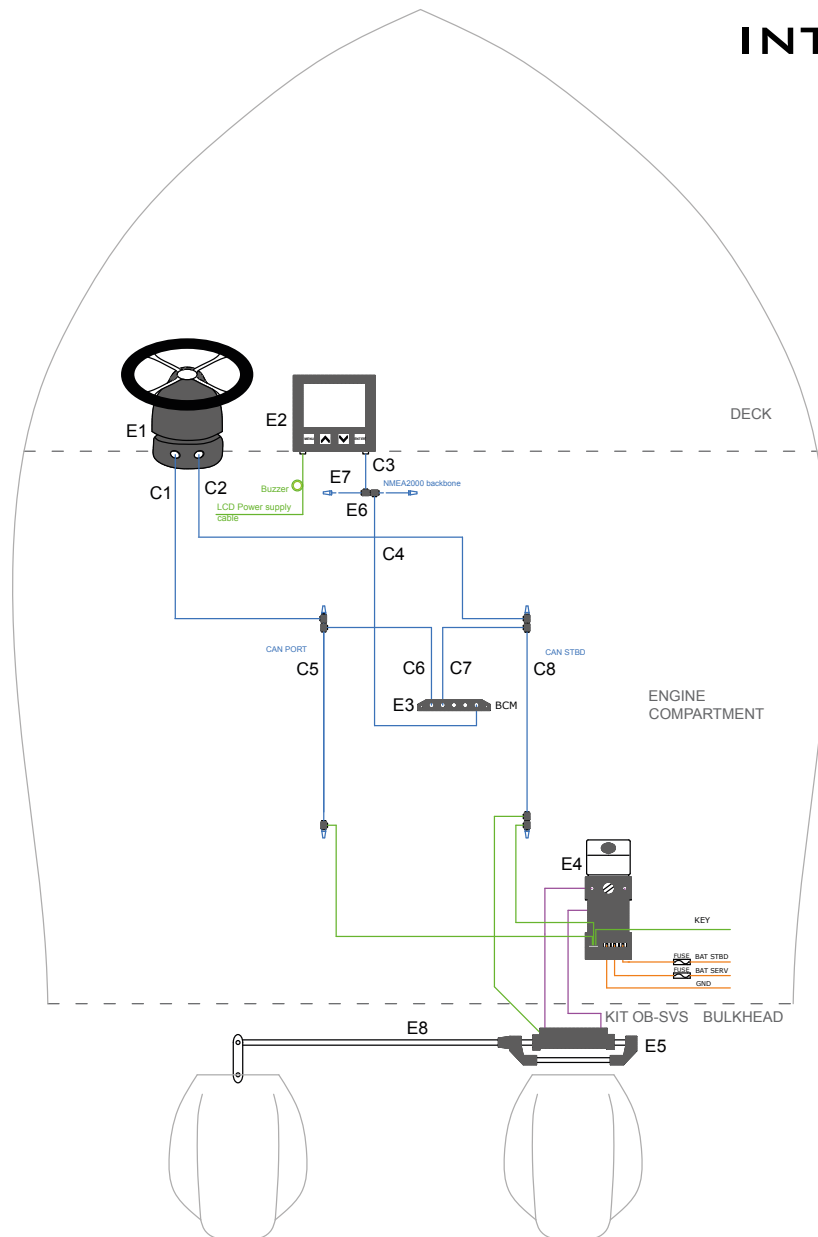

## Main components

Name	Description	Quantity
E1	UIH1 Electronic helm - 43536M	1
E1	X82 Tilt mechanism - 43187N	1
E2	Veratron display - 43539U	1
E3	BCM - Body control module - 43540C	1
E4	UIP Power Unit - 43541E or UIPC compact power unit - 43859N	1 or 1
E5	UC120E (or UC120EP) Cylinder with integrated sensor	1
E6	CAN bus - Tee connection - 43578E	9
E7	CAN bus - Terminator pair - 43576A	3
E8	A96-120 tie bar	1
C1-C8	CAN-bus cables - length on request	8
KIT OB-SVS	Hydraulic hoses kit - length on request	1

## Dual engine, dual cylinder

**INTEGRA EPS**

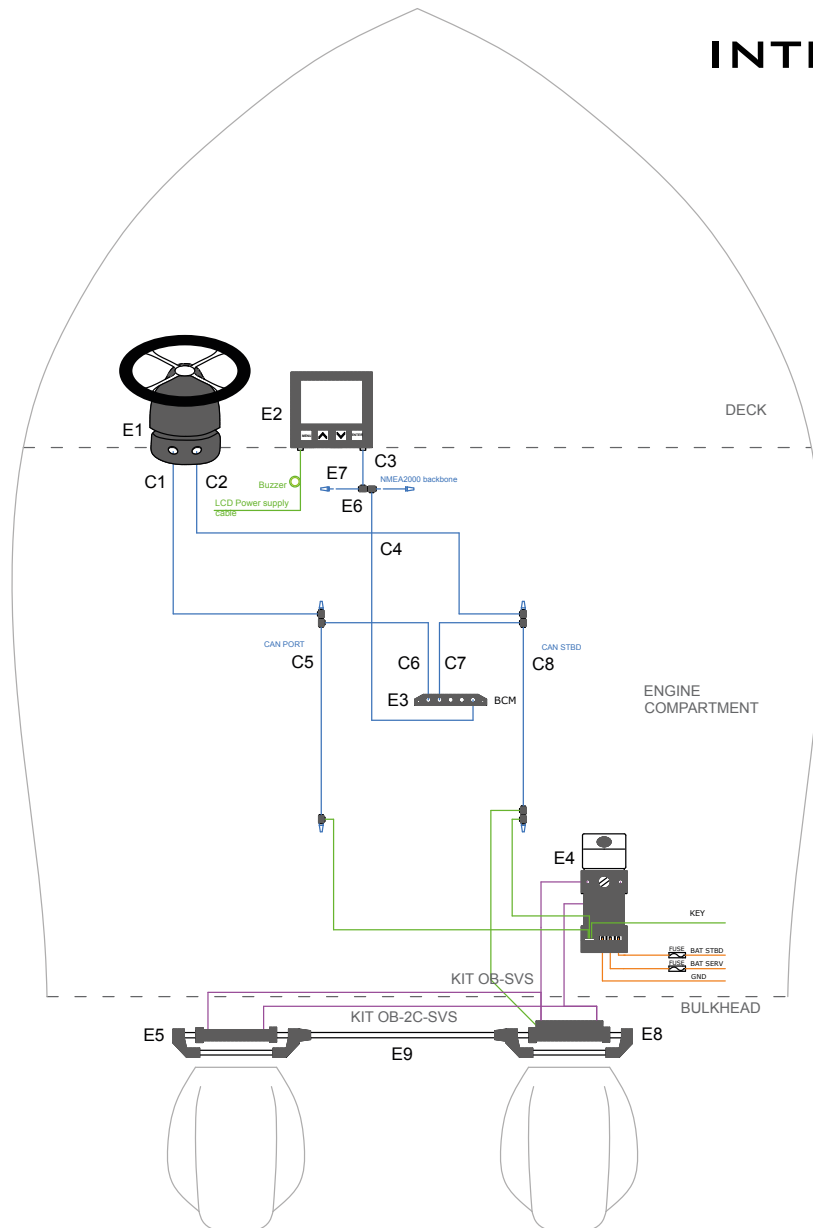

### Main components

Name	Description	Quantity
E1	UIH1 Electronic helm - 43536M	1
E1	X82 Tilt mechanism - 43187N	1
E2	Veratron display - 43539U	1
E3	BCM - Body control module - 43540C	1
E4	UIP Power Unit - 43541E	1
E5	UC120P (or UC120) Hydraulic cylinder	1
E6	CAN bus - Tee connection - 43578E	9
E7	CAN bus - Terminator pair - 43576A	3
E8	UC120E (or UC120EP) cylinder with integrated sensor	1
E9	A95-120 tie bar- Port cylinder to starboard cylinder connection	1
C1-C8	CAN-bus cables - length on request	8
KIT OB-SVS	Hydraulic hoses kit - length on request	1
KIT OB-2C-SVS	Hydraulic hoses kit - length on request	1



# Integra™ EPS Applications

Triple engine, dual cylinder

INTEGRA EPS

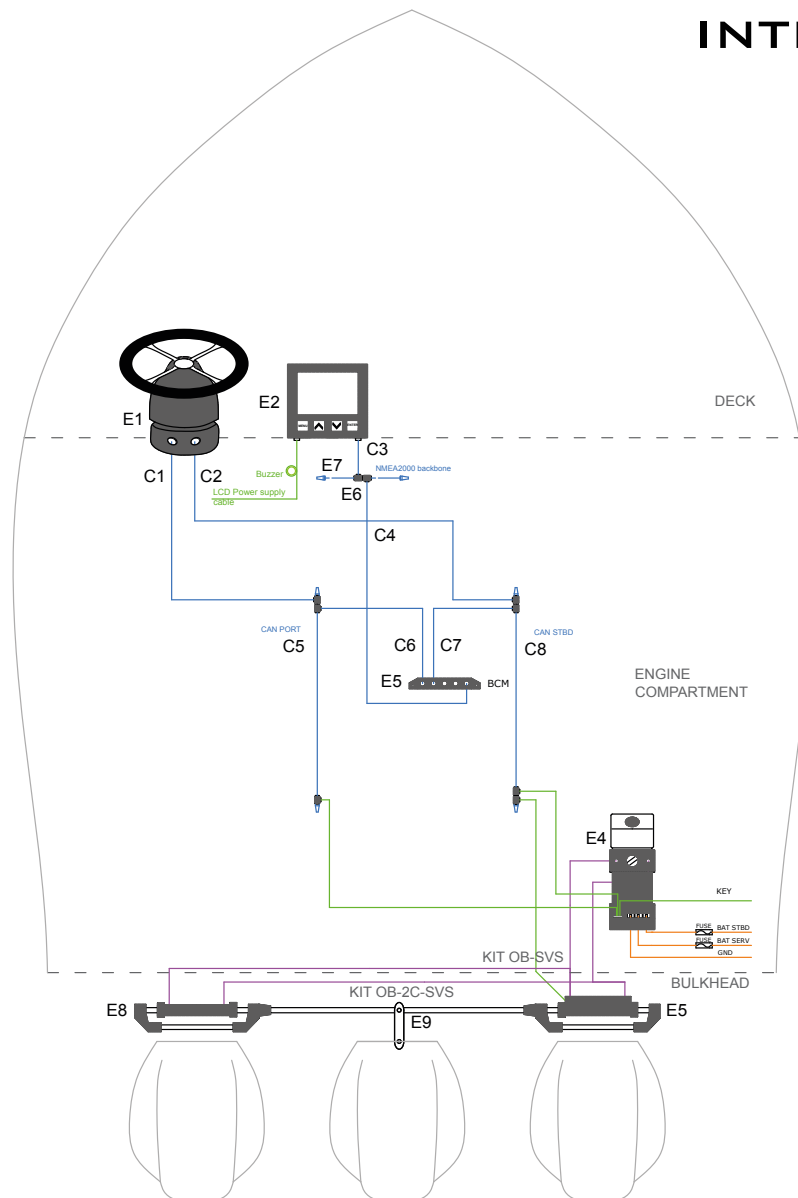

## Main components

Name	Description	Quantity
E1	UIH1 Electronic helm - 43536M	1
E1	X82 Tilt mechanism - 43187N	1
E2	Veratron display - 43539U	1
E3	BCM - Body control module - 43540C	1
E4	UIP Power Unit - 43541E	1
E5	UC120E (or UC120EP) Cylinder with integrated sensor	1
E6	CAN bus - Tee connection - 43578E	9
E7	CAN bus - Terminator pair - 43576A	3
E8	UC120P (or UC120) Hydraulic cylinder	1
E9	A97-120 tie bar	1
C1-C8	CAN-bus cables - length on request	8
KIT OB-SVS	Hydraulic hoses kit - length on request	1
KIT OB-2C-SVS	Hydraulic hoses kit - length on request	1

## Quad engine, dual cylinder

**INTEGRA EPS**

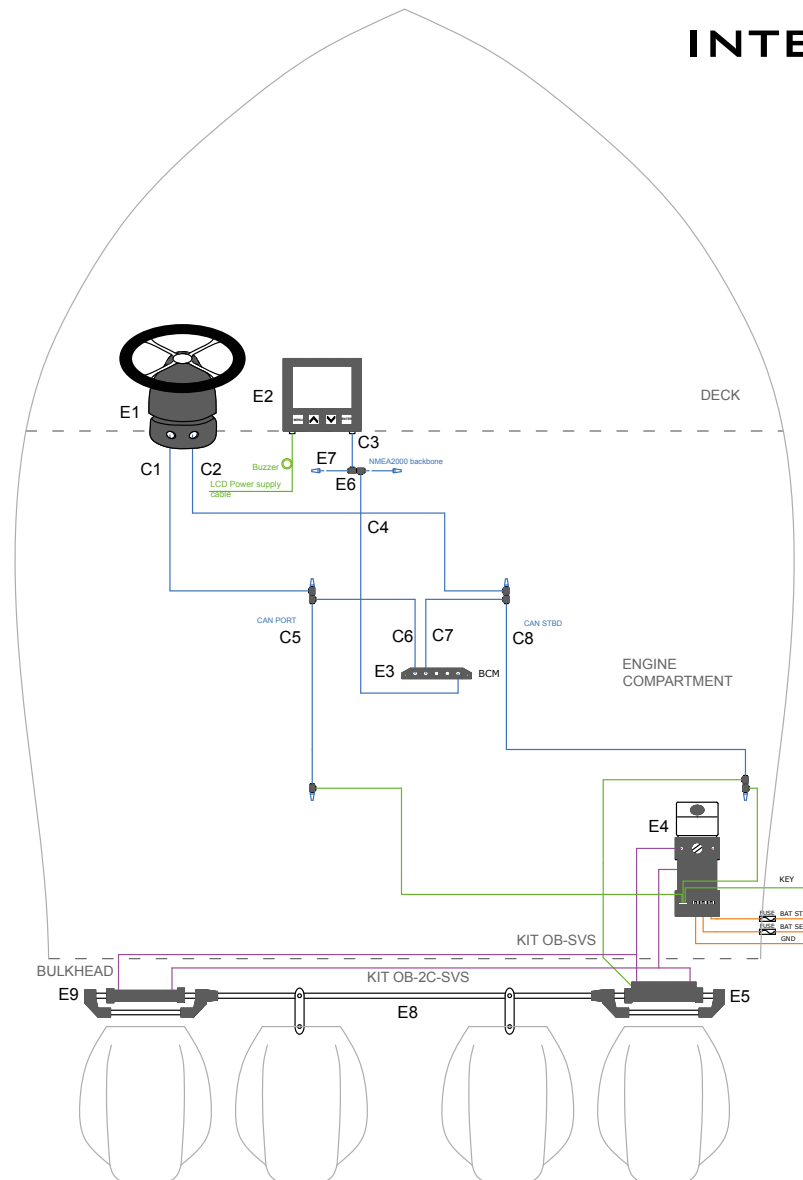

### Main components

Name	Description	Quantity
E1	UIH1 Electronic helm - 43536M	1
E1	X82 Tilt mechanism - 43187N	1
E2	Veratron display - 43539U	1
E3	BCM - Body control module - 43540C	1
E4	UIP Power Unit - 43541E	1
E5	UC120E (or UC120EP) Cylinder with integrated sensor	1
E6	CAN bus - Tee connection - 43578E	9
E7	CAN bus - Terminator pair - 43576A	3
E8	UC120P (or UC120) Hydraulic cylinder	1
E9	A98-120 tie bar	1
C1-C8	CAN-bus cables - length on request	8
KIT OB-SVS	Hydraulic hoses kit - length on request	1
KIT OB-2C-SVS	Hydraulic hoses kit - length on request	1

# Integra™ CEPS Applications

Dual engine, dual cylinder, dual power unit

INTEGRA CEPS

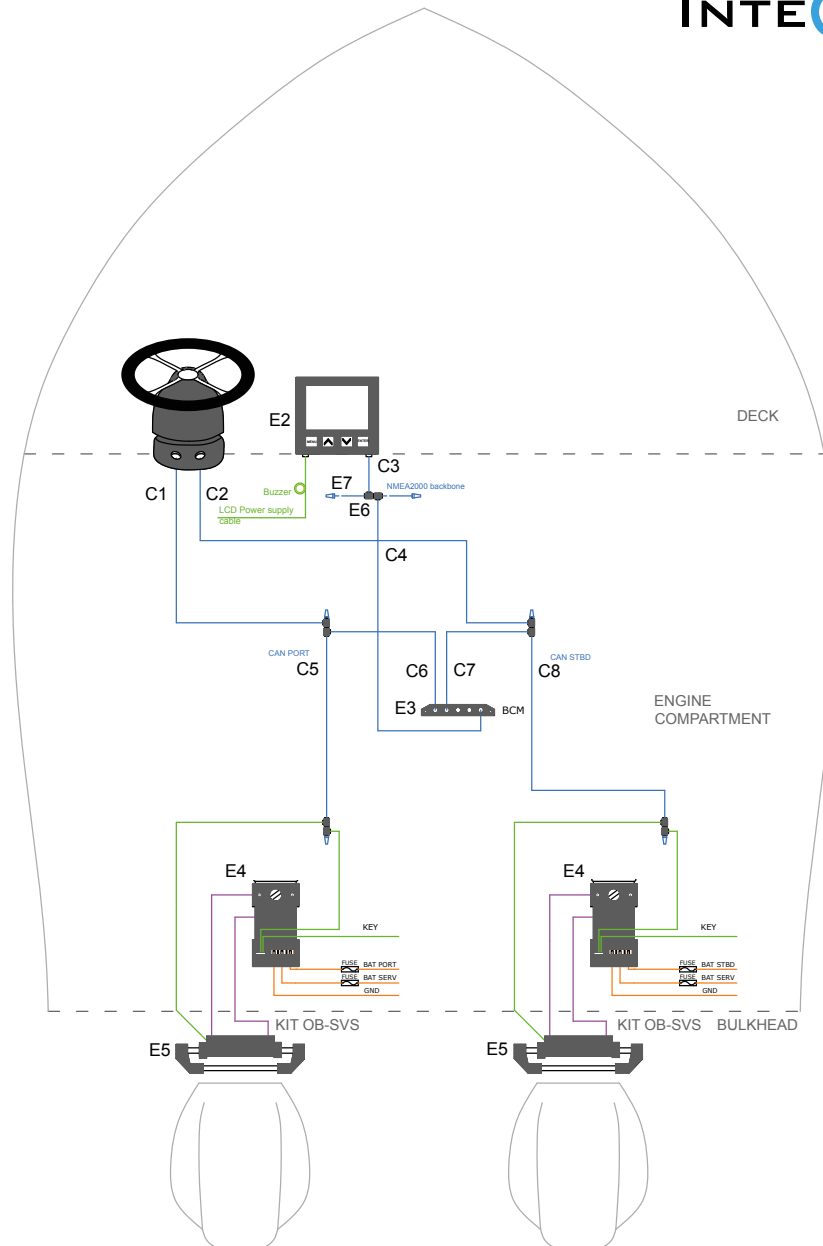

## Main components

Name	Description	Quantity
E1	UIH1 Electronic helm - 43536M	1
E1	X82 Tilt mechanism - 43187N	1
E2	Veratron display - 43539U	1
E3	BCM - Body control module - 43540C	1
E4	UIPC compact power unit - 43859N	2
E5	UC120E (or UC120EP) Cylinder with integrated sensor	2
E6	CAN bus - Tee connection - 43578E	10
E7	CAN bus - Terminator pair - 43576A	3
C1-C8	CAN-bus cables - length on request	8
KIT OB-SVS	Hydraulic hoses kit - length on request	2

## Quad engine, dual cylinder, dual power unit

INTEGRA CEPS

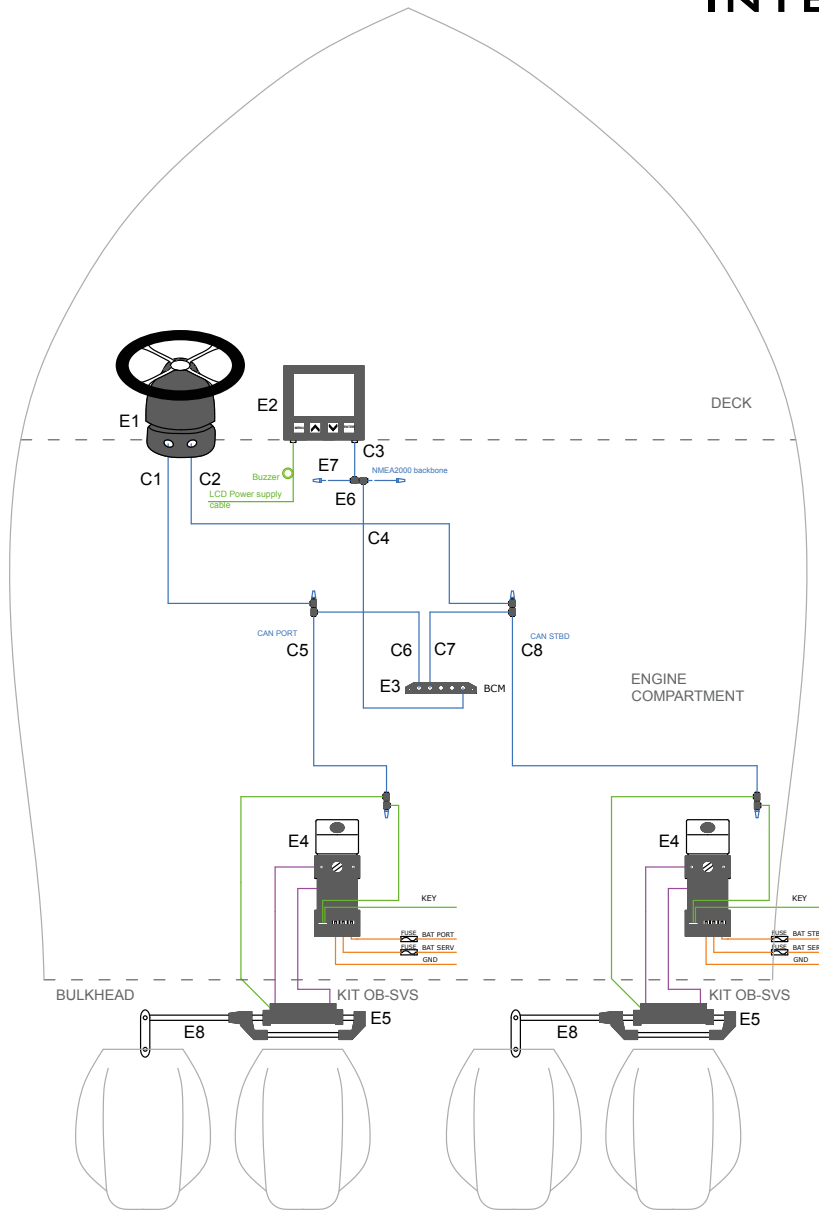

### Main components

Name	Description	Quantity
E1	UIH1 Electronic helm - 43536M	1
E1	X82 Tilt mechanism - 43187N	1
E2	Veratron display - 43539U	1
E3	BCM - Body control module - 43540C	1
E4	UIP Power Unit - 43541E or UIPC compact power unit - 43859N	2
E5	UC120E (or UC120EP) Cylinder with integrated sensor	2
E6	CAN bus - Tee connection - 43578E	10
E7	CAN bus - Terminator pair - 43576A	3
E8	A96-120 tie bar	2
C1-C8	CAN-bus cables - length on request	8
KIT OB-SVS	Hydraulic hoses kit - length on request	2

# Integra™ CEPS Applications

Single engine, single cylinder, single power unit

INTEGRA JS

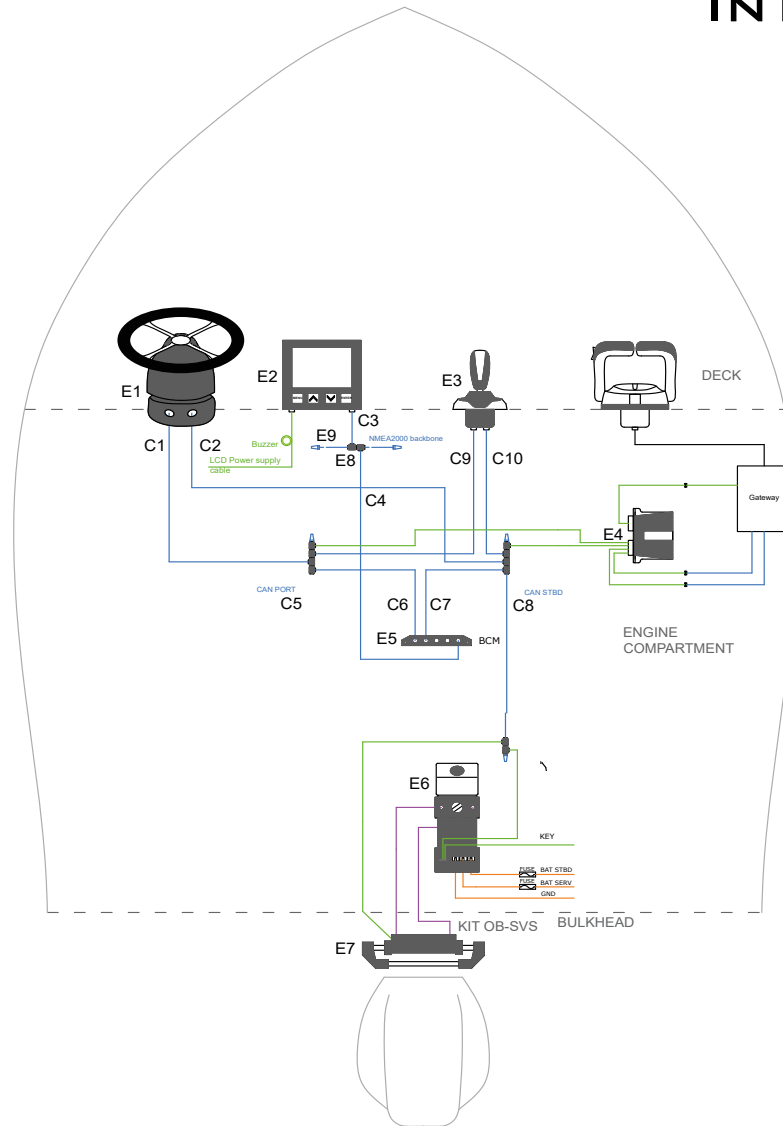

## Main components

Name	Description	Quantity
E1	UIH1 Electronic helm - 43536M	1
E1	X82 Tilt mechanism - 43187N	1
E2	Veratron display - 43539U	1
E3	UJS joystick	1
E4	Gateway	1
E5	BCM - Body control module - 43540C	1
E6	UIPC compact power unit - 43859N	2
E7	UC120E (or UC120EP) Cylinder with integrated sensor	2
E8	CAN bus - Tee connection - 43578E	14
E9	CAN bus - Terminator pair - 43576A	3
C1-C10	CAN-bus cables - length on request	10
KIT OB-SVS	Hydraulic hoses kit - length on request	2

Single engine, single cylinder, single power unit with bow thruster

## INTEGRA JS

new

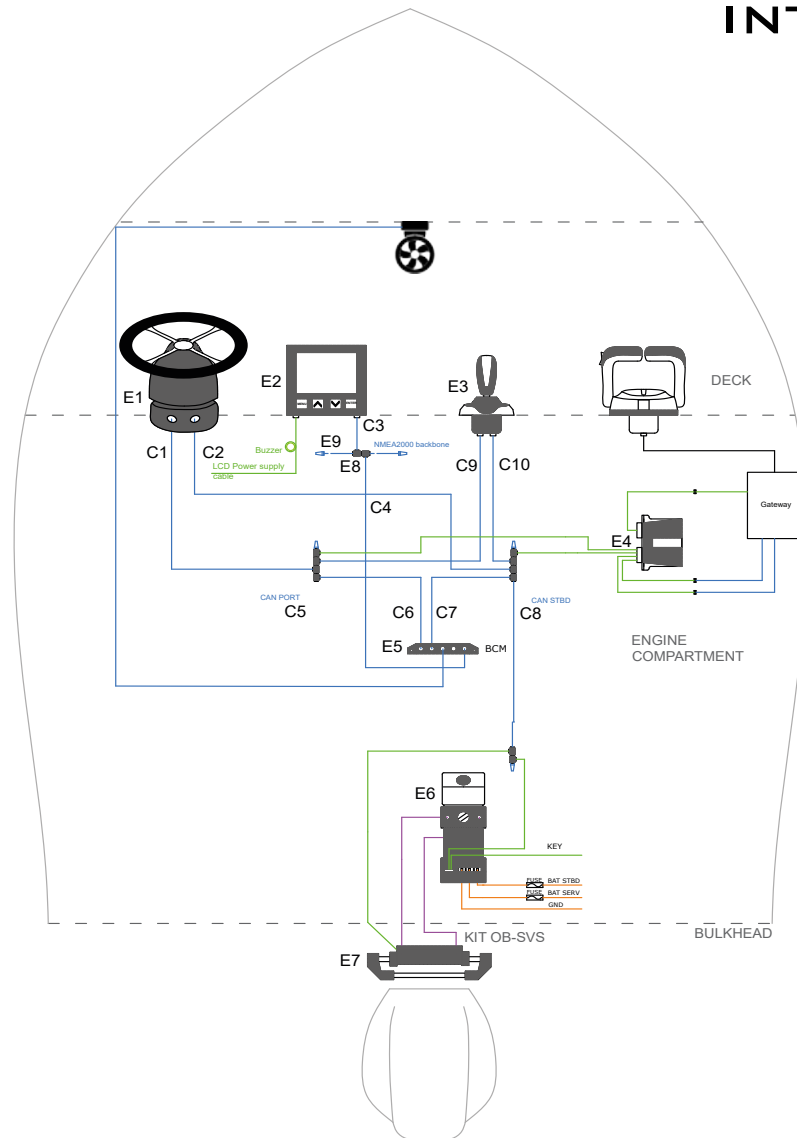

### Main components

Name	Description	Quantity
E1	UIH1 Electronic helm - 43536M	1
E1	X82 Tilt mechanism - 43187N	1
E2	Veratron display - 43539U	1
E3	UJS-B joystick	1
E4	Gateway	1
E5	BCM - Body control module - 43540C	1
E6	UIPC compact power unit - 43859N	2
E7	UC120E (or UC120EP) Cylinder with integrated sensor	2
E8	CAN bus - Tee connection - 43578E	14
E9	CAN bus - Terminator pair - 43576A	3
C1-C10	CAN-bus cables - length on request	10
KIT OB-SVS	Hydraulic hoses kit - length on request	2



# Integra™ JS Applications

Dual engine, dual cylinder, dual power unit

INTEGRA JS

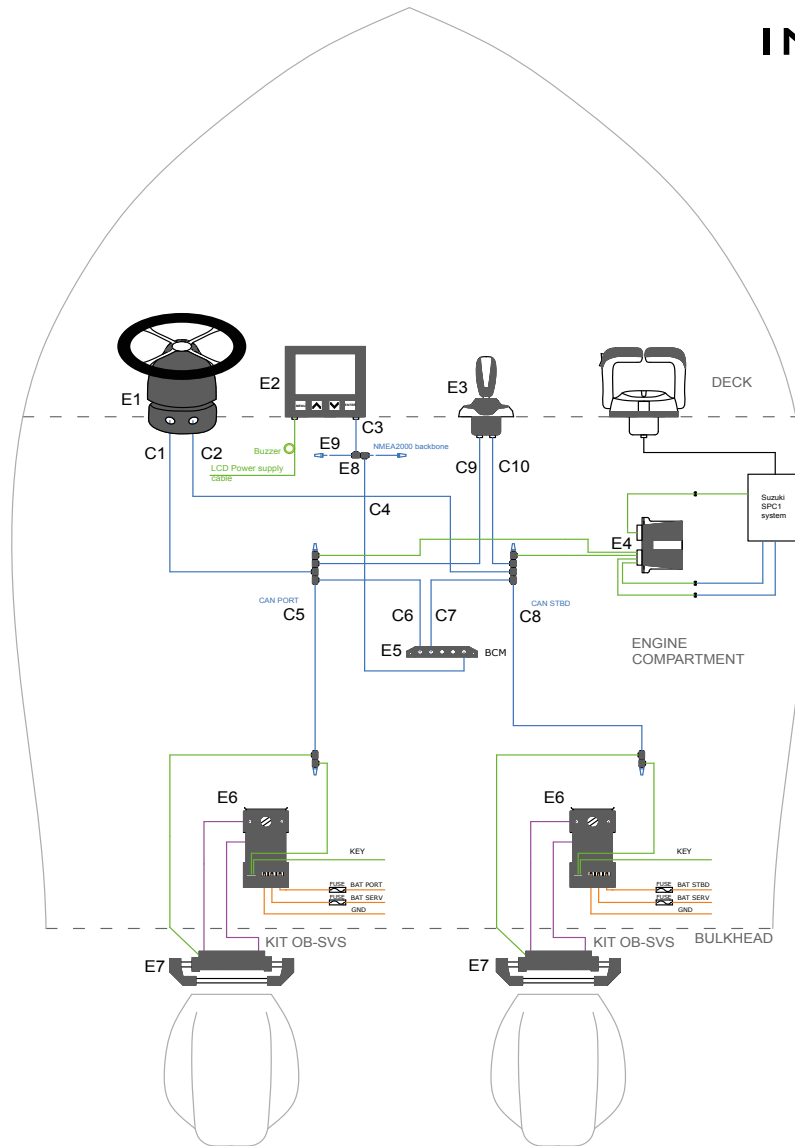

## Main components

Name	Description	Quantity
E1	UIH1 Electronic helm - 43536M	1
E1	X82 Tilt mechanism - 43187N	1
E2	Veratron display - 43539U	1
E3	UJS joystick	1
E4	Gateway	1
E5	BCM - Body control module - 43540C	1
E6	UIP Power Unit 43541E or UIPC compact power unit - 43859N	2
E7	UC120E (or UC120EP) Cylinder with integrated sensor	2
E8	CAN bus - Tee connection - 43578E	14
E9	CAN bus - Terminator pair - 43576A	3
E10	A96-120 tie bar	1
C1-C10	CAN-bus cables - length on request	10
KIT OB-SVS	Hydraulic hoses kit - length on request	2

Dual engine, dual cylinder, dual power unit with bow thruster

## INTEGRA JS

new

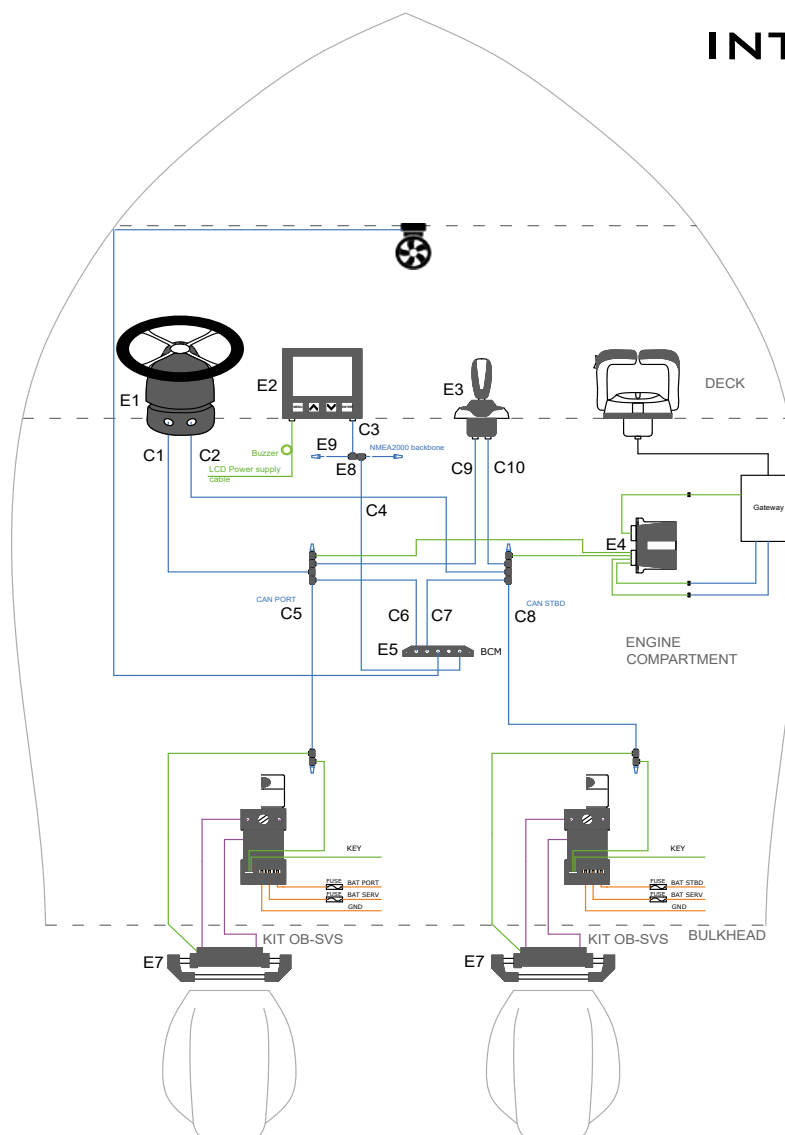

### Main components

Name	Description	Quantity
E1	UIH1 Electronic helm - 43536M	1
E1	X82 Tilt mechanism - 43187N	1
E2	Veratron display - 43539U	1
E3	UJS-B joystick	1
E4	Gateway	1
E5	BCM - Body control module - 43540C	1
E6	UIPC compact power unit - 43859N	2
E7	UC120E (or UC120EP) Cylinder with integrated sensor	2
E8	CAN bus - Tee connection - 43578E	14
E9	CAN bus - Terminator pair - 43576A	3
C1-C10	CAN-bus cables - length on request	10
KIT OB-SVS	Hydraulic hoses kit - length on request	2

# Integra™ JS Applications

Triple engine, dual cylinder, dual power unit

INTEGRA JS

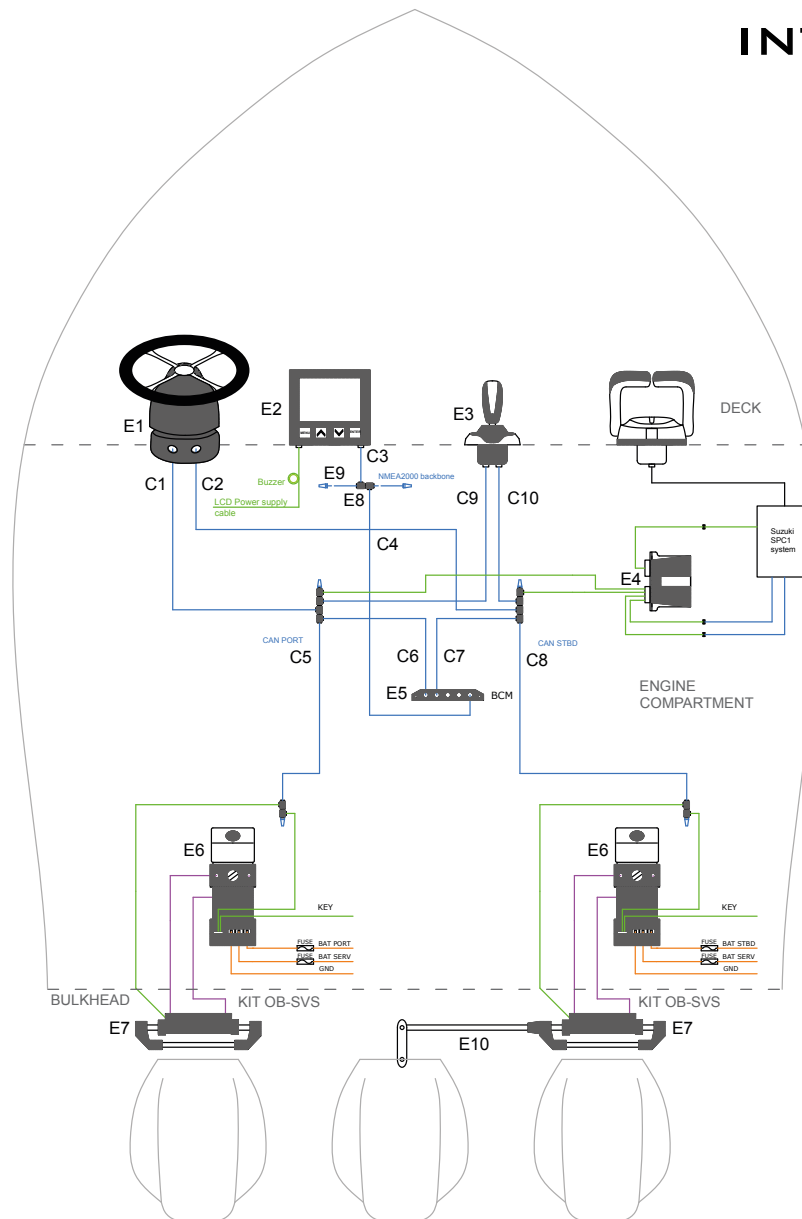

## Main components

Name	Description	Quantity
E1	UIH1 Electronic helm - 43536M	1
E1	X82 Tilt mechanism - 43187N	1
E2	Veratron display - 43539U	1
E3	UJS joystick - 43922T	1
E4	Gateway	1
E5	BCM - Body control module - 43540C	1
E6	UIP Power Unit 43541E or UIPC compact power unit - 43859N	2
E7	UC120E (or UC120EP) Cylinder with integrated sensor	2
E8	CAN bus - Tee connection - 43578E	14
E9	CAN bus - Terminator pair - 43576A	3
E10	A96-120 tie bar	1
C1-C10	CAN-bus cables - length on request	10
KIT OB-SVS	Hydraulic hoses kit - length on request	2

## Quad engine, dual cylinder, dual power unit

INTEGRA JS

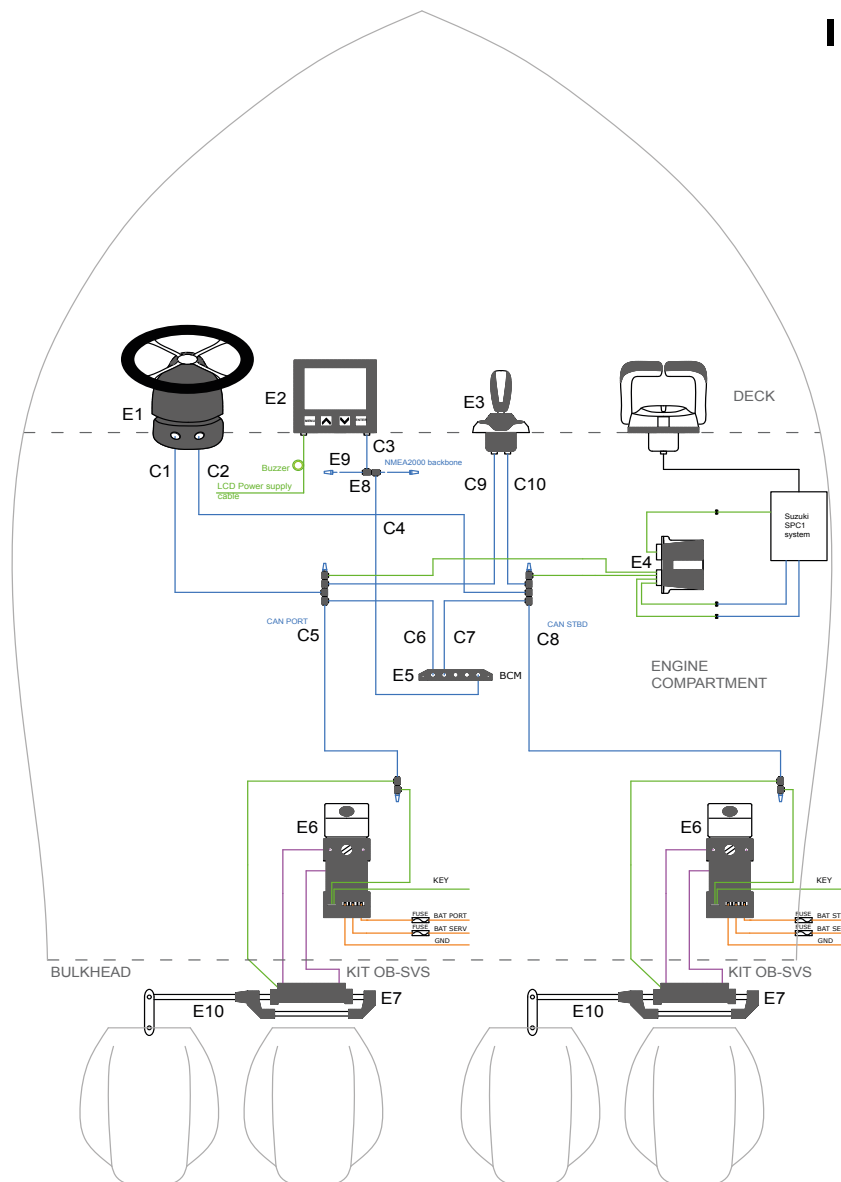

### Main components

Name	Description	Quantity
E1	UIH1 Electronic helm - 43536M	1
E1	X82 Tilt mechanism - 43187N	1
E2	Veratron display - 43539U	1
E3	UJS joystick - 43922T	1
E4	Gateway	1
E5	BCM - Body control module - 43540C	1
E6	UIP Power Unit - 43541E or UIPC compact power unit - 43859N	2
E7	UC120E Starboard cylinder with integrated sensor	1
E8	CAN bus - Tee connection - 43578E	14
E9	CAN bus - Terminator pair - 43576A	3
E10	A96-120 tie bar	2
E11	UC120EP Port cylinder with integrated sensor	1
C1-C10	CAN-bus cables - length on request	10
KIT OB-SVS	Hydraulic hoses kit - length on request	2

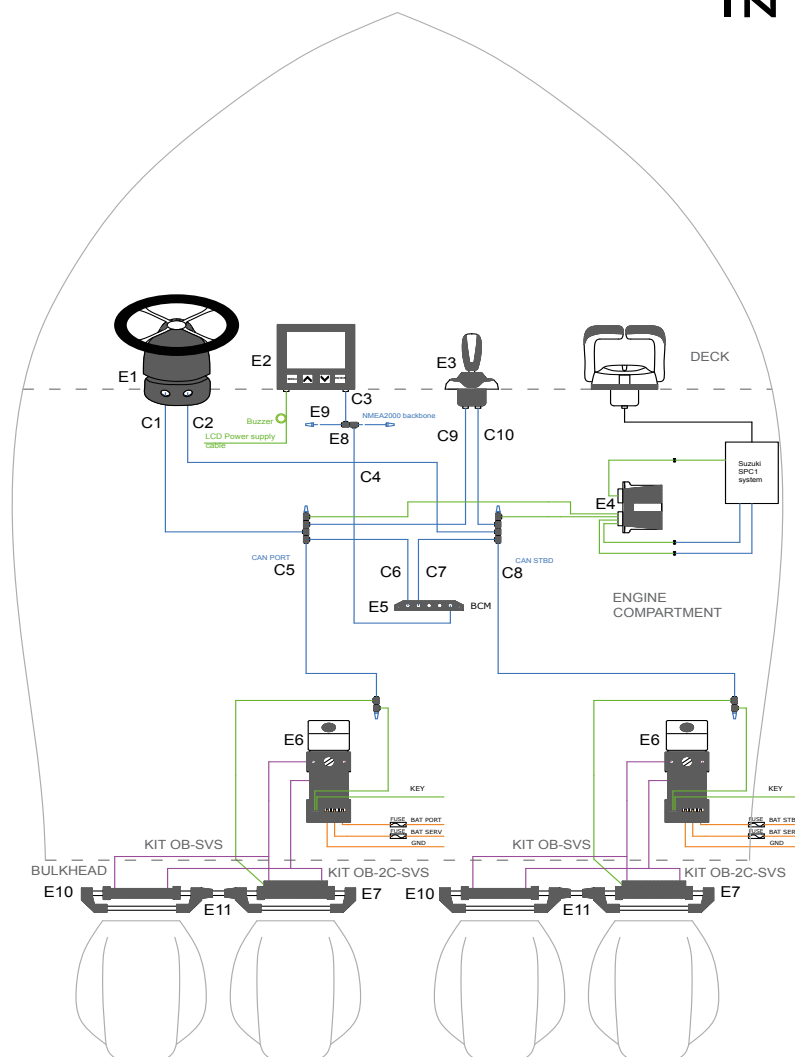

### Main components

Name	Description	Quantity
E1	UIH1 Electronic helm - 43536M	1
E1	X82 Tilt mechanism - 43187N	1
E2	Veratron display - 43539U	1
E3	UJS joystick - 43922T	1
E4	Gateway	1
E5	BCM - Body control module - 43540C	1
E6	UIP Power Unit - 43541E	2
E7	UC120E Starboard cylinder with integrated sensor	1
E8	CAN bus - Tee connection - 43578E	14
E9	CAN bus - Terminator pair - 43576A	3
E10	UC120 Starboard hydraulic cylinder	1
E11	A95-120 tie bar - Port cylinder to starboard cylinder connection	2
E12	UC120P Port hydraulic cylinder	1
E13	UC120EP Port cylinder with integrated sensor	1
C1-C10	CAN-bus cables - length on request	10
KIT OB-SVS / KIT OB-2C-SVS	Hydraulic hoses kit - length on request	2

Integra™ equipped with UPA123  
Outboard electronic power steering systems

new

# INTEGRA JS

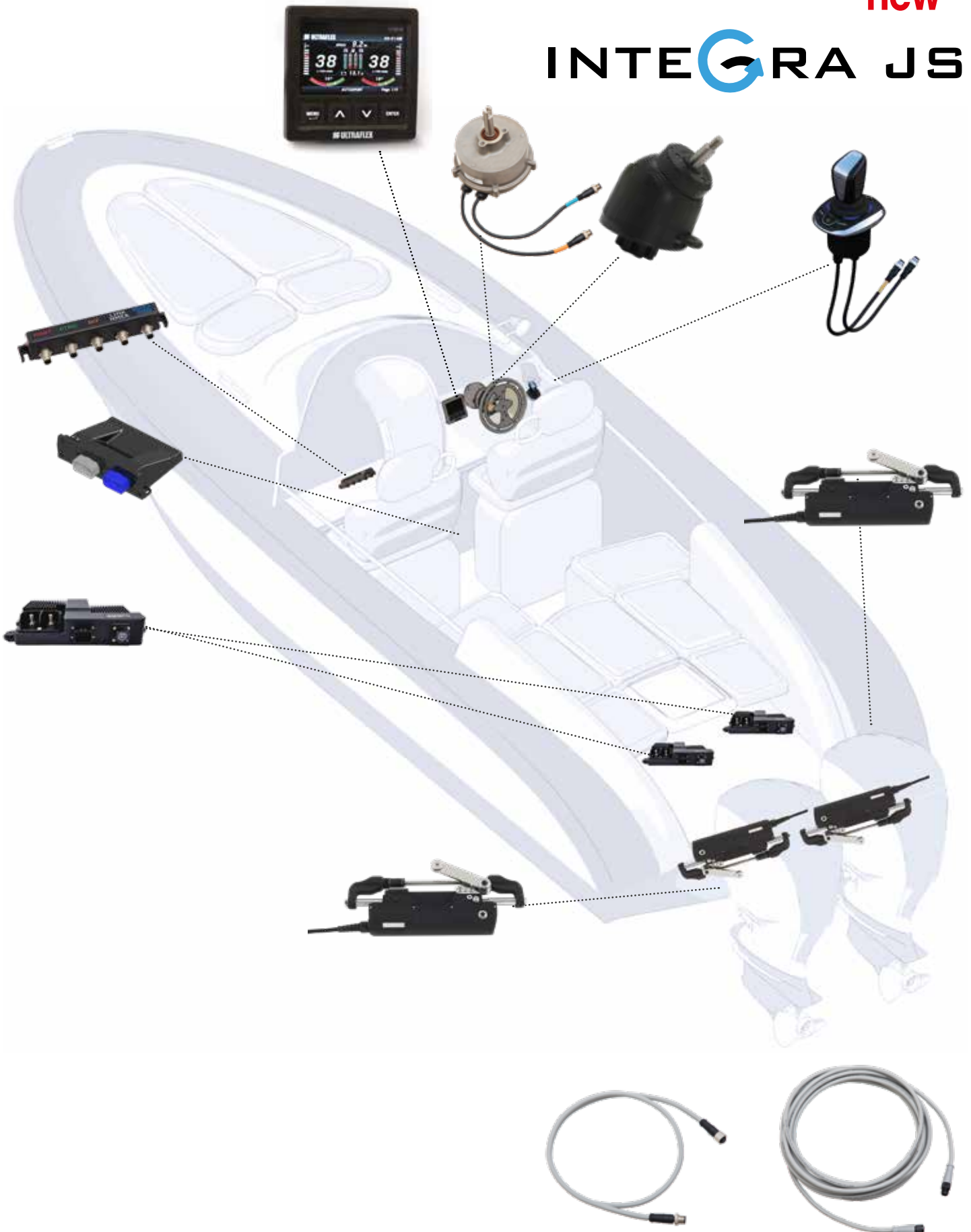



# Integra™ equipped with UPA123 Outboard electronic power steering system

## System components

UIH	Tilt mount electronic helm
UJS	Integra JS joystick
UGW	Integra JS Gateway
X82	Adjustable steering wheel tilt mechanism
UID	Veratron® / VDO® colour display
BCM	Body Control Module -Can Bus network module
UPA123	Electronic power Starboard actuator
UPA123P	Electronic power port actuator
DC/DC Converter	Voltage converter for UP123 actuator
A96UPA	Tie bar for Integra with UPA123 steering systems
CANbus wires	Can bus power wires

## Technical specifications

- Operating voltage: 12VDC
- Temperature range: -25°C/+77°C
- Outboard engine installations: single, dual, triple, quad
- Autopilot direct interface:
  - **Garmin®** Corepack Reactor 40 SBW
  - **Raymarine®** pack EV-2 SBW
  - **Furuno®** Navpilot 300
  - **Simrad®** Ap44 and Ap48 with NAC-D
- Customizable driving mode: Autocruise and Autosport
- Customizable wheel effort
- Compliance with rules: ISO 25197, ISO 10592, ABYC P21, P24, P27
- Ignition Protected SAE J1171



# Integra™ equipped with UPA123 Outboard electronic power steering systems

## Integra EPS and Integra JS with UPA123 key benefits

- **Redundant electronic steering system**, a reliable way to reduce steering effort, tuning your driving and enhancing steering experience.
- **Plug & play system**
- **Absence of hydraulic hoses onboard . - no purging operations required**
- **Virtually maintenance free**
- **Integra JS with UPA123 is ready for use**, once installed
- **Reduced size wire**: can be easily connected and disconnected to/from the actuator, thanks its the specific connector
- **Integra JS** adds to Integra EPS functionalities a new level of manoeuvrability, thanks to the **Joystick technology**
- **Integra JS is a more intuitive way of driving**. Designed for **low speed manoeuvring**, the Joystick grants precision and driving comfort and **facilitates docking and trailer procedures** as the boat can move sideways, diagonally or spin on its own axis
- **Integra JS Joystick** includes several functions: **Boost** function used to momentarily increase engine rpm if you need instant thrust, **Heading** function, which gives the possibility to keep the direction of the bow set, **Anchor** function, to maintain boat position via GPS connection, **MainStay** the combination of the previous functions (**Heading** and **Anchor**). The **Heading** , **Anchor** and **MainStay** functions require the **Veratron® Nav Sensor - 20201Z**
- **Powerful output, great efficiency and quickest response** in any situation, thanks to the brushless motor of the pump unit and to the electronic management
- **Extremely silent**
- **Low amperage system**
- **Veratron® colour display**
- **Customizable driving mode**: the user can choose between Autocruise and Autosport driving mode
- **Autopilot direct interface**: **Garmin®** Reactor™ 40 Steer-by-wire, **Raymarine®** EV-2 SBW, **Furuno®** Navipilot 300, **Simrad®** Ap44 and Ap48 with NAC-D
- **Easy installation**, thanks to the simplified configuration and the CAN bus connection system.
- **Customizable wheel effort**.
- Wheel effort is programmed to change with engine RPM.
- **Tilt range of 48° and 5 locking positions**, thanks to the **X82** tilt mechanisms
- **Easy boat handling**: adjustable speed sensitive turns lock to lock
- Designed for single, dual, triple or quad outboard engines
- Available for multiple steering stations applications



# Integra™ equipped with UPA123 Outboard electronic power steering systems

UPA123 - Electronic power actuator



**new**



UPA123P

- Plug & play system
- Absence of hydraulic hoses onboard . - no purging operations required
- Virtually maintenance free
- Integra JS with UPA123 is ready for use, once installed
- **Reduced size wire:** it can be easily connected and disconnected to/from the actuator, thanks to its specific connector

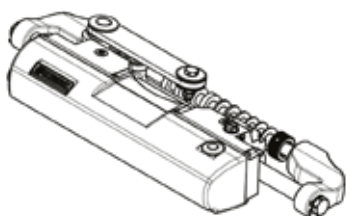

UPA123-OBF/1

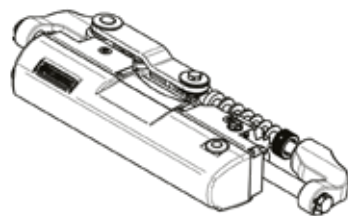

UPA123-OBF/2

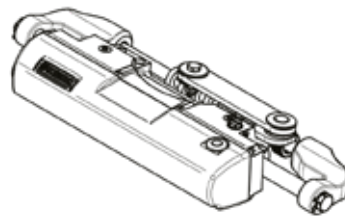

UPA123P-OBF/1

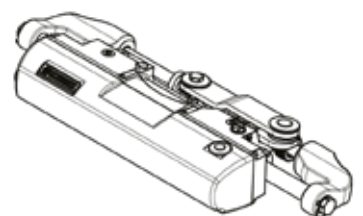

UPA123P-OBF/2

Modello	Codice	Descrizione
UPA123-OBF/1	44007N	Front mount electronic actuator, starboard version
UPA123-OBF/2	44009T	Front mount electronic actuator, starboard version
UPA123P-OBF/1	43851W	Front mount electronic actuator, port version
UPA123P-OBF/2	44008R	Front mount electronic actuator, port version

Max load	700 kg (1555 lbs)
Stroke	184 mm (7.24")
Nominal voltage with DCDC converter	12VDC
MAX tension	55A

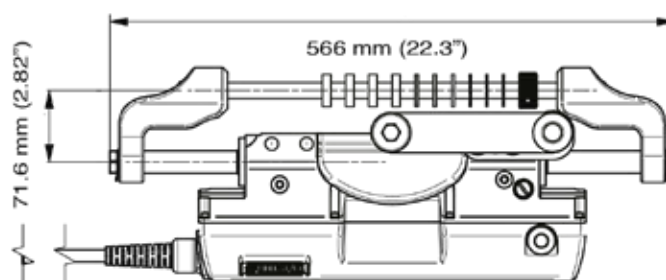

UPA123 - DIMENSIONS

# Integra™ equipped with UPA123 Outboard electronic power steering systems

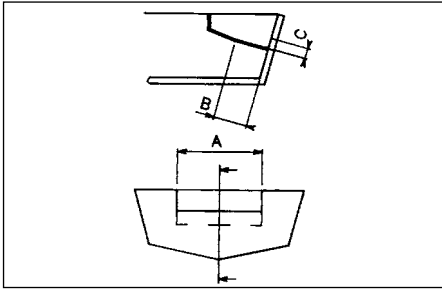

SPLASHWELL DIMENSION REQUIREMENTS			
Engine No.	A	B	C
1	560 mm - 22.05"	152 mm - 5.98"	152 mm - 5.98"
2	1110 mm - 43.70"	152 mm - 5.98"	152 mm - 5.98"

## UPA123 electronic actuator applications

ENGINE	MODEL	YEAR	ACTUATOR STARBOARD	P. No.	ACTUATOR PORT	P. No.
Mercury® Mariner®	115-125-150 EFI 2S	1990-2007	UPA123-OBF/1	44007N	UPA123P-OBF/1	43851W
	225-250 EFI 2S	2000-2007	UPA123-OBF/1	44007N	UPA123P-OBF/1	43851W
	135-150-175 OPTIMAX	1999-2018	UPA123-OBF/1	44007N	UPA123P-OBF/1	43851W
	200-225-250 OPTIMAX	1999-2018	UPA123-OBF/1	44007N	UPA123P-OBF/1	43851W
	RACING 300 OPTIMAX	1999-2011	UPA123-OBF/1	44007N	UPA123P-OBF/1	43851W
	250 SALTWATER EFI 4S	2007-2011	UPA123-OBF/1	44007N	UPA123P-OBF/1	43851W
	135-150-175-200 VERADO L4	2004-2012	UPA123-OBF/1	44007N	UPA123P-OBF/1	43851W
	FOURSTROKE 175-200 V6	2018-to date	UPA123-OBF/1	44007N	UPA123P-OBF/1	43851W
	FOURSTROKE 225-300 V8	2018-to date	UPA123-OBF/1	44007N	UPA123P-OBF/1	43851W
Evinrude®	E115-E130-E135 2S V4	1995-to date	UPA123-OBF/2	44009T	UPA123P-OBF/2	44008R
	E150-E175-E200-E225-E250-E300 2S V6	1995-to date	UPA123-OBF/2	44009T	UPA123P-OBF/2	44008R
Yamaha®	150F-200F-250G 2S	1990-2008	UPA123-OBF/2	44009T	UPA123P-OBF/2	44008R
	150 HPDI VMAX 2S	1996-2007	UPA123-OBF/2	44009T	UPA123P-OBF/2	44008R
	175-200-225-250-300 HPDI VMAX 2S	2000-2008	UPA123-OBF/2	44009T	UPA123P-OBF/2	44008R
	F115-F150 EFI 4S	2000-2008	UPA123-OBF/1	44007N	UPA123P-OBF/1	43851W
	F200-F225-F250 4S	1999-2007	UPA123-OBF/2	44009T	UPA123P-OBF/2	44008R
	F115-F150-F175-F200 L4	2002-2007	UPA123-OBF/1	44007N	UPA123P-OBF/1	43851W
	F200-F225-F250-F300 V6 4S F350 4S V8	2004-to date 2006-to date	UPA123-OBF/2 UPA123-OBF/1	44009T 44007N	UPA123P-OBF/2 UPA123P-OBF/1	44008R 43851W
Honda®	BF135-BF150 4S	2005-to date	UPA123-OBF/1	44007N	UPA123P-OBF/1	43851W
	BF150 V-TEC 4S	2008-to date	UPA123-OBF/1	44007N	UPA123P-OBF/1	43851W
	BF175-BF200-BF225- BF250 4S	2001-to date	UPA123-OBF/1	44007N	UPA123P-OBF/1	43851W
Suzuki®	DF100-115-140 4S	2008-to date	UPA123-OBF/1	44007N	UPA123P-OBF/1	43851W
	DF150-175-DF200 L4 4S	2006-to date	UPA123-OBF/1	44007N	UPA123P-OBF/1	43851W
	DF200-DF225-DF250-DF300-DF350 V6 4S	2004-to date	UPA123-OBF/2	44009T	UPA123P-OBF/2	43851W
Tohatsu®	115-120-140 2S	2004-to date	UPA123-OBF/2	44009T	UPA123P-OBF/2	44008R
	70-90-115 TLDI 4S	2004-to date	UPA123-OBF/1	44007N	UPA123P-OBF/1	43851W
	BFT 115-150-200-225-250 4S	2014-to date	UPA123-OBF/1	44007N	UPA123P-OBF/1	43851W
	BFT60-75-90	2015-to date	UPA123-OBF/1	44007N	UPA123P-OBF/1	43851W
Selva®	80 PORTOFINO/TIGERSHARK 2S	1995-2008	UPA123-OBF/1	44007N	UPA123P-OBF/1	43851W
	150 WHITE SHARK 2S	2001-2007	UPA123-OBF/2	44009T	UPA123P-OBF/2	43433B
	100EFI MARLIN -115 EFI NARWHAL	2000-to date	UPA123-OBF/1	44007N	UPA123P-OBF/1	43851W
	225 BEAKED WHALE 4S	2019-to date	UPA123-OBF/2	44009T	UPA123P-OBF/2	43433B
	150EFI KILLER WHALE 4S - 200 SEI WHALE 4S	2000-to date	UPA123-OBF/1	44007N	UPA123P-OBF/1	43851W
Johnson®	BJ90-115-140 4S	2001-2007	UPA123-OBF/1	44007N	UPA123P-OBF/1	43851W
	J90-115 V4 2S	1995-2007	UPA123-OBF/2	44009T	UPA123P-OBF/2	44008R
	J150-175 V6 2S	1995-2007	UPA123-OBF/2	44009T	UPA123P-OBF/2	44008R
	J200-225 V6 4S	2004-2007	UPA123-OBF/2	44009T	UPA123P-OBF/2	44008R
OXE®	125-150-175-200HP DIESEL	2018-to date	UPA123-OBF/1	44007N	UPA123P-OBF/1	43851W
	300 HP DIESEL	2020-to date	UPA123-OBF/1	44007N	UPA123P-OBF/1	43851W
COX®	300 HP	2020-to date	UPA123-OBF/2	44009T	UPA123P-OBF/2	44008R

# Integra™ equipped with UPA123 Outboard electronic power steering systems

DCDC converter

**new**



DCDC converter

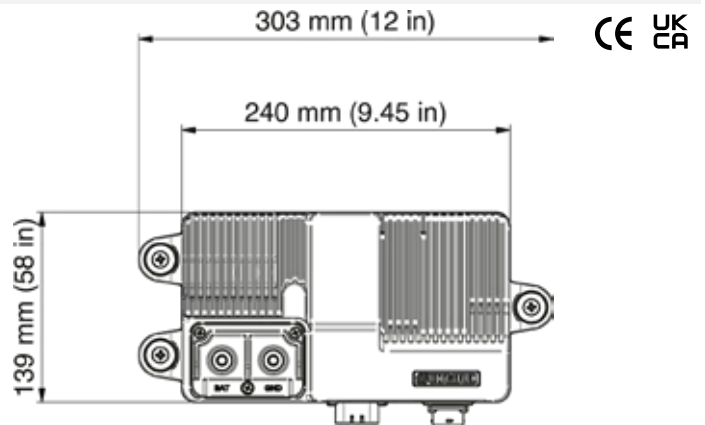

DCDC converter dimensions

DCDC converter - 43993T

DCDC converter is a component of **Integra™ with UPA123** electronic power system. Every electronic actuator needs to be connected to a dedicated DCDC converter.

## A96-UPA - Tie bar for twin outboard engine/single UPA123 electronic actuator

Tie bars suitable with Integra™ equipped with UPA123 electronic power steering system only



A96-UPA M/Y



A96-UPA S/H

Two different lengths available:  
From 26" to 29" engine center  
From 29" to 34.5" engine center

A96-UPA M/Y-29	44036W	From 26" to 29" engine center - For Mercury® and Yamaha® engines
A96-UPA M/Y-34.5	44035U	From 29" to 34.5" engine center - For Mercury® and Yamaha® engines
A96-UPA S/H-29	44038A	From 26" to 29" engine center - For Suzuki® and Honda® engines
A96-UPA S/H-34.5	44037Y	From 29" to 34.5" engine center - For Suzuki® and Honda® engines

# Integra™ EPS equipped with UPA123 Applications

Single engine, single actuator

**INTEGRA EPS**

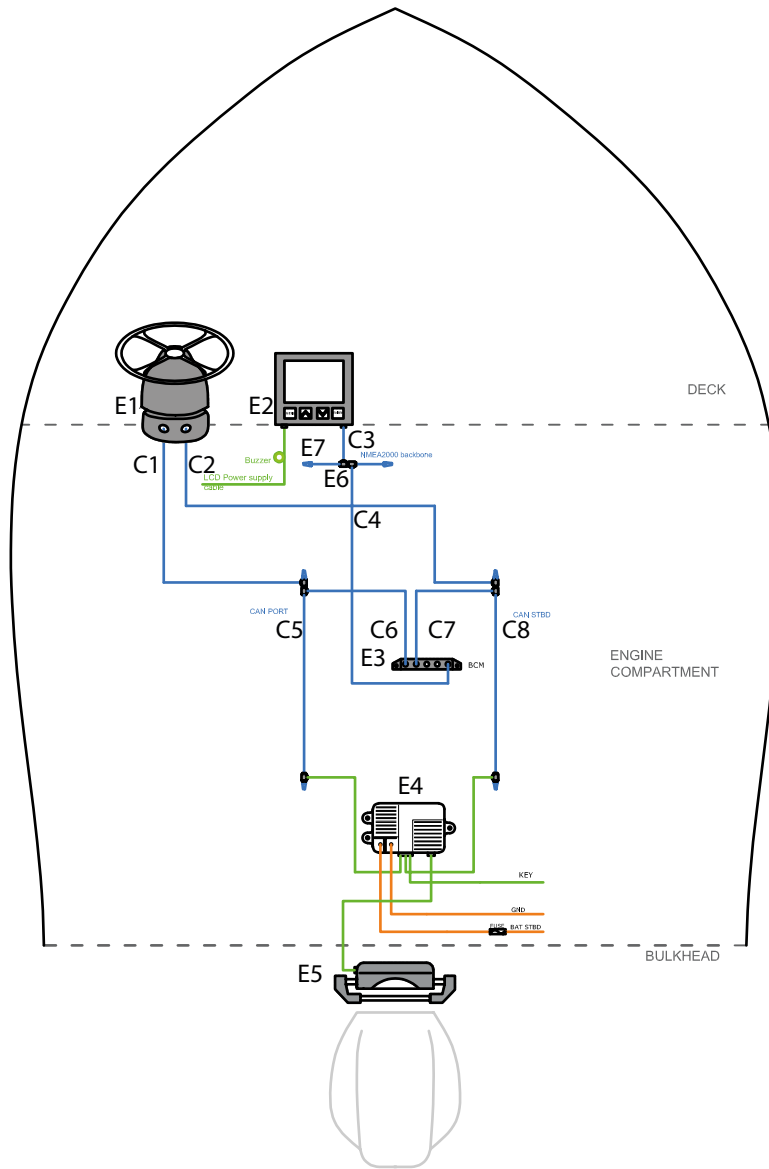

## Main components

Name	Description	Quantity
E1	UIH1 Electronic helm - 43536M	1
E1	X82 Tilt mechanism - 43187N	1
E2	Veratron display - 43539U	1
E3	BCM - Body control module - 43540C	1
E4	UPA Driver - DC/DC Converter - 43993T	1
E5	UPA123 (or UPA123P) - Electronic actuator	1
E6	CAN bus - Tee connection - 43578E	8
E7	CAN bus - Terminator pair - 43576A	3
C1-C8	CAN-bus cables - length on request	8



# Integra™ CEPS equipped with UPA123 Applications

Dual engine, dual actuator

INTEGRA CEPS

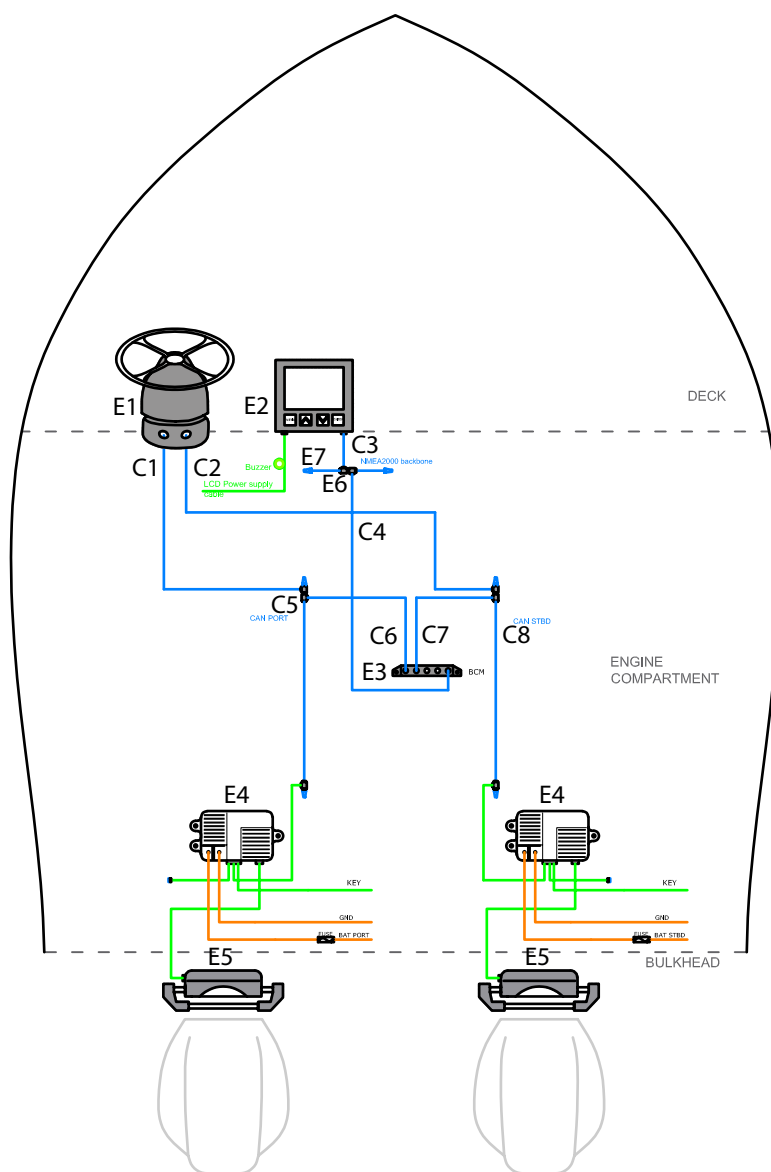

## Main components

Name	Description	Quantity
E1	UIH1 Electronic helm - 43536M	1
E1	X82 Tilt mechanism - 43187N	1
E2	Veratron display - 43539U	1
E3	BCM - Body control module - 43540C	1
E4	UPA Driver - DC/DC Converter - 43993T	2
E5	UPA123 (or UPA123P) Electronic actuator	2
E6	CAN bus - Tee connection - 43578E	8
E7	CAN bus - Terminator pair - 43576A	3
C1-C8	CAN-bus cables - length on request	8

Single engine, single actuator

## INTEGRA JS

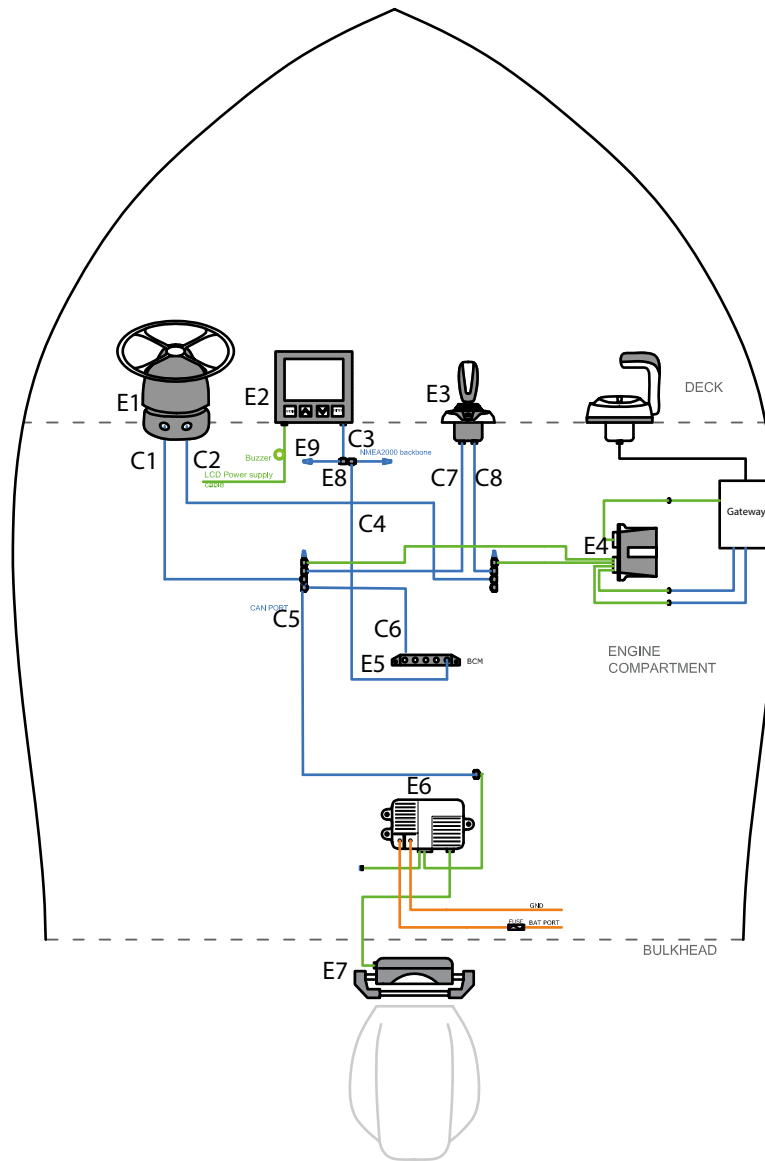

### Main components

Name	Description	Quantity
E1	UIH1 Electronic helm - 43536M	1
E1	X82 Tilt mechanism - 43187N	1
E2	Veratron display - 43539U	1
E3	UJS joystick - 43922T	1
E4	Gateway	1
E5	BCM - Body control module - 43540C	1
E6	UPA Driver - DC/DC Converter - 43993T	2
E7	UPA123 (or UPA123P) - Electronic actuator	2
E8	CAN bus - Tee connection - 43578E	8
C1-C8	CAN-bus cables - length on request	10

# Integra™ JS equipped with UPA123 Applications

Single engine, single actuator with bow thruster

**new**

**INTEGRA JS**

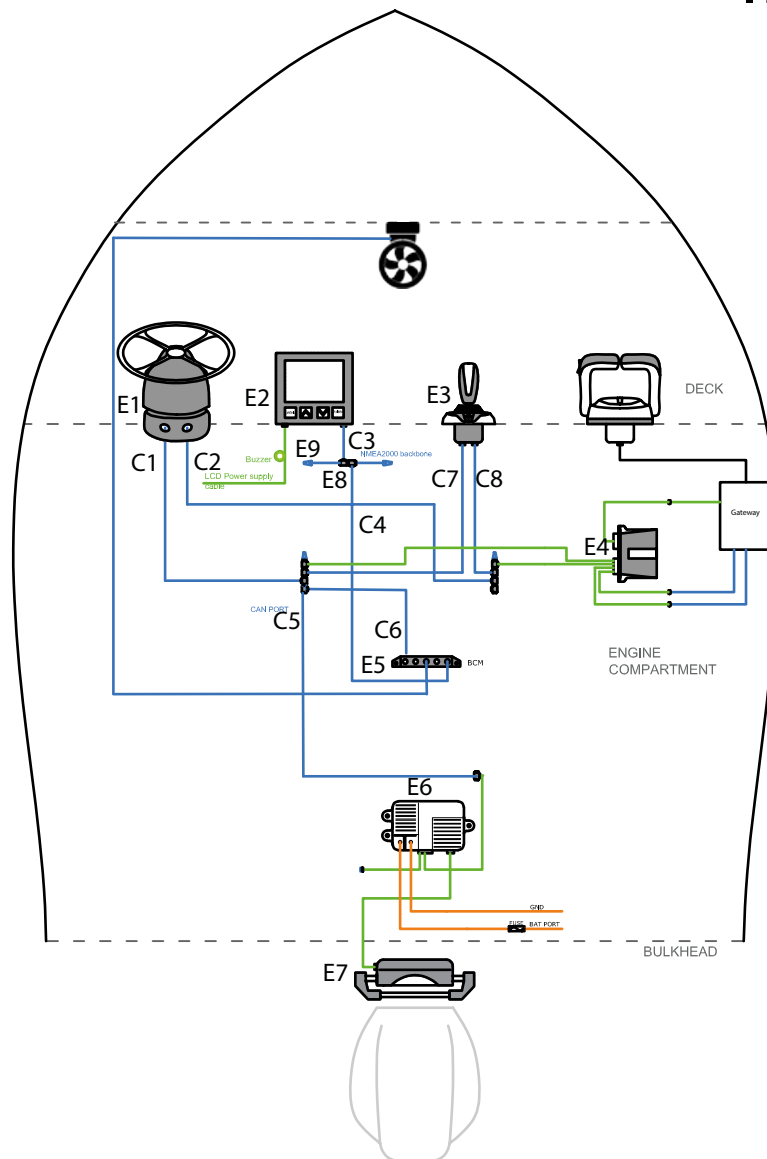

## Main components

Name	Description	Quantity
E1	UIH1 Electronic helm - 43536M	1
E1	X82 Tilt mechanism - 43187N	1
E2	Veratron display - 43539U	1
E3	UJS-B joystick - 44162B	1
E4	Gateway	1
E5	BCM - Body control module - 43540C	1
E6	UPA Driver - DC/DC Converter - 43993T	2
E7	UPA123 (or UPA123P) - Electronic actuator	2
E8	CAN bus - Tee connection - 43578E	8
E9	CAN bus - Terminator pair - 43576A	3
C1-C8	CAN-bus cables - length on request	10

Dual engine, dual actuator

INTEGRA JS

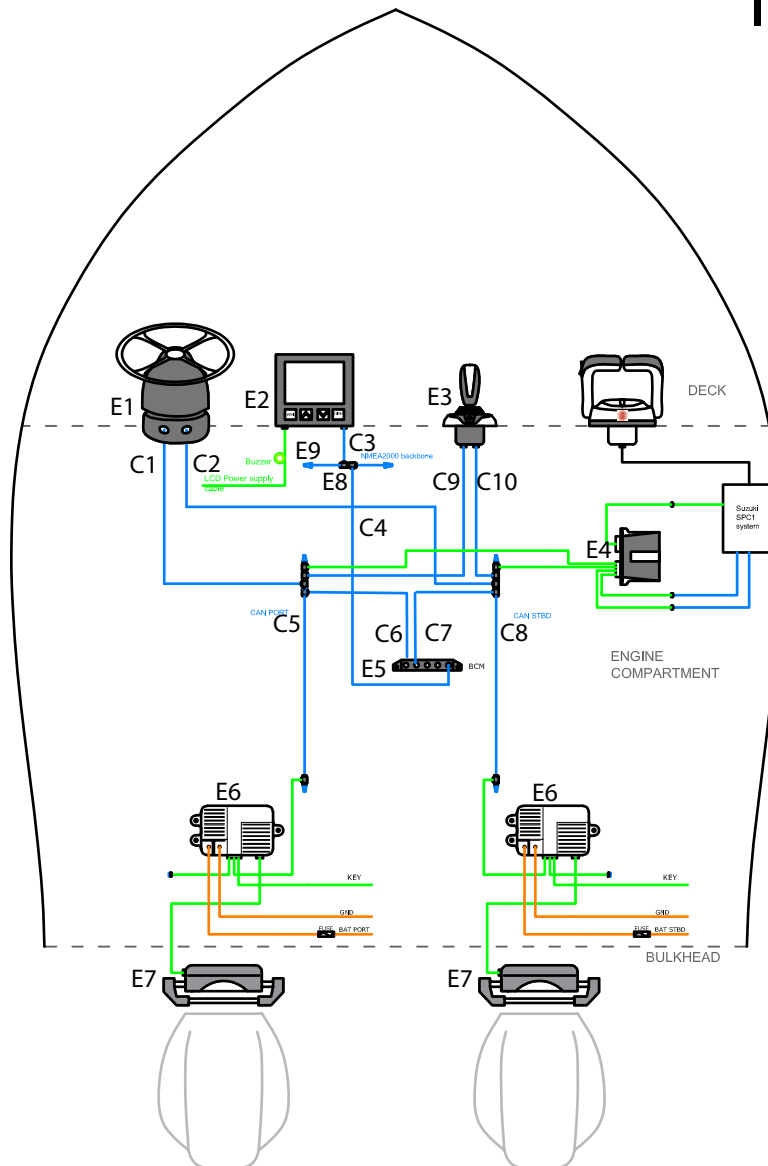

## Main components

Name	Description	Quantity
E1	UIH1 Electronic helm - 43536M	1
E1	X82 Tilt mechanism - 43187N	1
E2	Veratron display - 43539U	1
E3	UJS joystick - 43922T	1
E4	Gateway	1
E5	BCM - Body control module - 43540C	1
E6	UPA Driver - DC/DC Converter - 43993T	2
E7	UPA123 (or UPA123P) - Electronic actuator	2
E8	CAN bus - Tee connection - 43578E	12
E9	CAN bus - Terminator pair - 43576A	3
C1-C10	CAN-bus cables - length on request	10

# Integra™ JS equipped with UPA123 Applications

Dual engine, dual actuator with bow thruster

INTEGRA JS

new

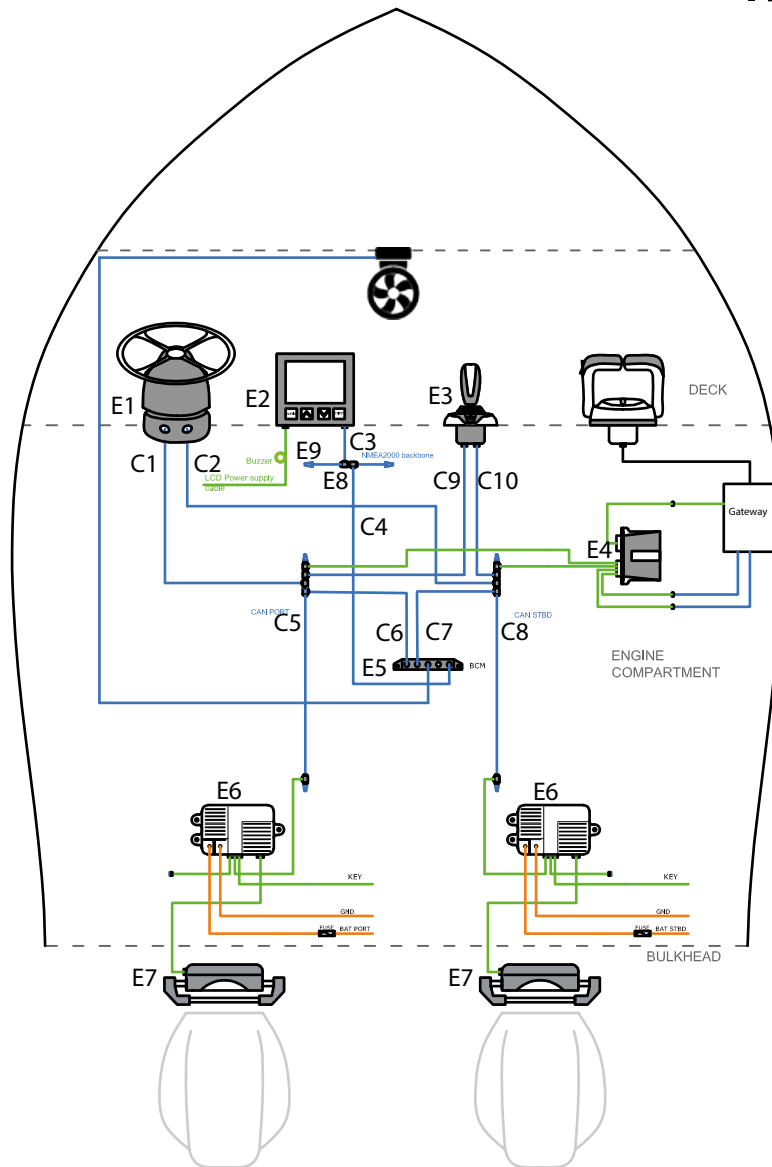

## Main components

Name	Description	Quantity
E1	UIH1 Electronic helm - 43536M	1
E1	X82 Tilt mechanism - 43187N	1
E2	Veratron display - 43539U	1
E3	UJS-B joystick - 44162B	1
E4	Gateway	1
E5	BCM - Body control module - 43540C	1
E6	UPA Driver - DC/DC Converter - 43993T	2
E7	UPA123 (or UPA123P) - Electronic actuator	2
E8	CAN bus - Tee connection - 43578E	12
E9	CAN bus - Terminator pair - 43576A	3
C1-C10	CAN-bus cables - length on request	10

Triple engine, dual actuator

INTEGRA JS

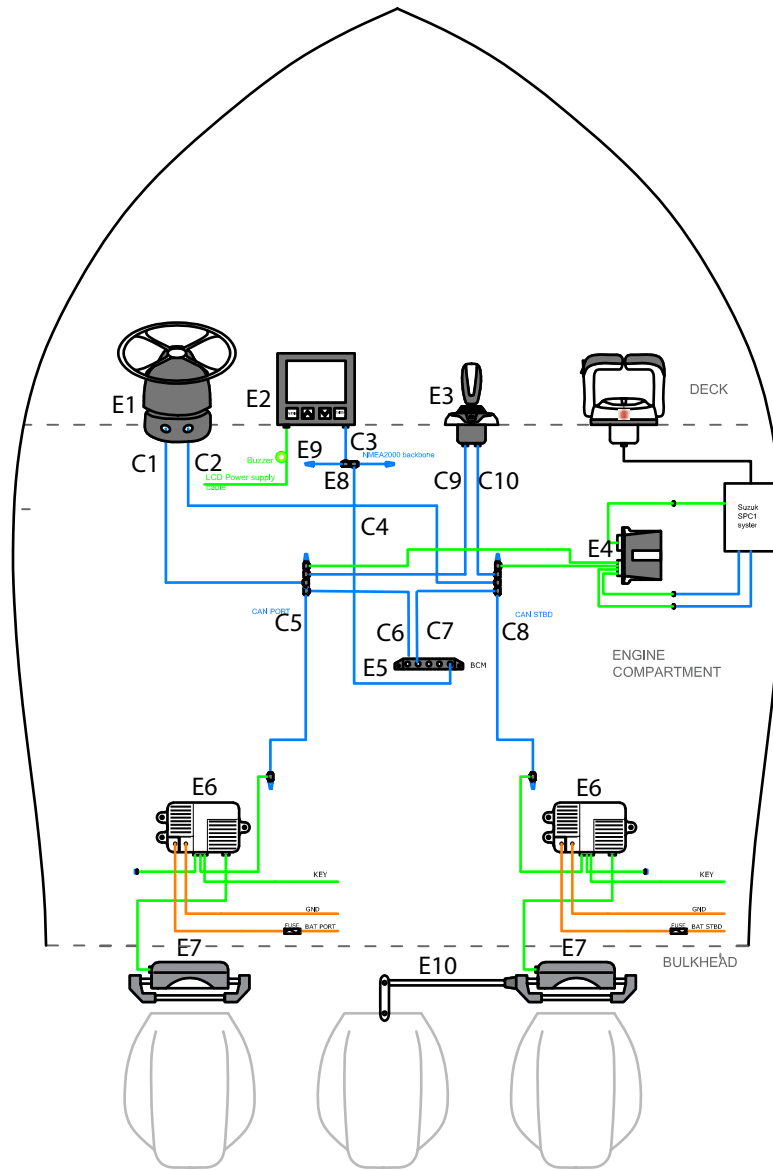

## Main components

Name	Description	Quantity
E1	UIH1 Electronic helm - 43536M	1
E1	X82 Tilt mechanism - 43187N	1
E2	Veratron display - 43539U	1
E3	UJS joystick - 43922T	1
E4	Gateway	1
E5	BCM - Body control module - 43540C	1
E6	UPA Driver - DC/DC Converter - 43993T	2
E7	UPA123 (or UPA123P) - Electronic actuator	2
E8	CAN bus - Tee connection - 43578E	12
E9	CAN bus - Terminator pair - 43576A	3
E10	A96-120 tie bar	1
C1-C10	CAN-bus cables - length on request	10



# Integra™ JS equipped with UPA123 Applications

Quad engine, dual actuator

INTEGRA JS

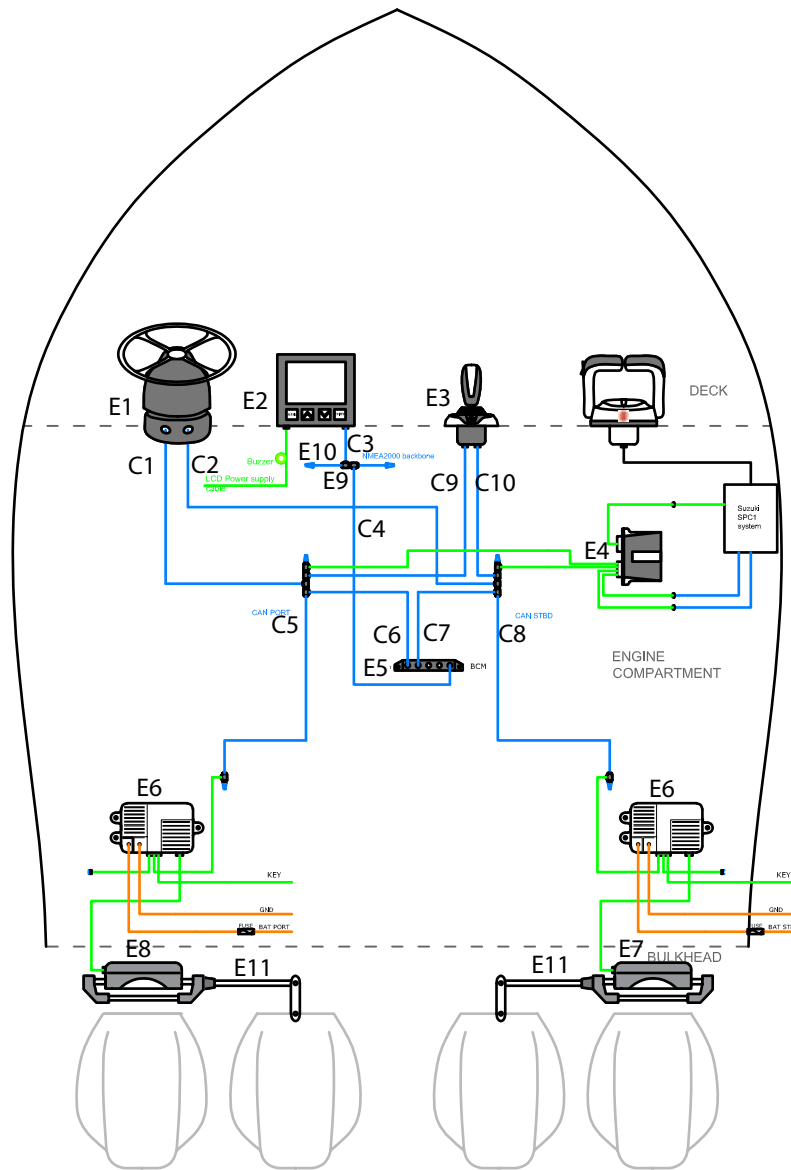

## Main components

Name	Description	Quantity
E1	UIH1 Electronic helm - 43536M	1
E1	X82 Tilt mechanism - 43187N	1
E2	Veratron display - 43539U	1
E3	UJS joystick - 43922T	1
E4	Gateway	1
E5	BCM - Body control module - 43540C	1
E6	UPA Driver - DC/DC Converter - 43993T	2
E7	UPA123 Electronic starboard actuator	1
E8	UPA123P Electronic port actuator	1
E9	CAN bus - Tee connection - 43578E	12
E10	CAN bus - Terminator pair - 43576A	3
E11	A96-120 tie bar	2



# Inboard steering systems

## Single steering station installation diagram

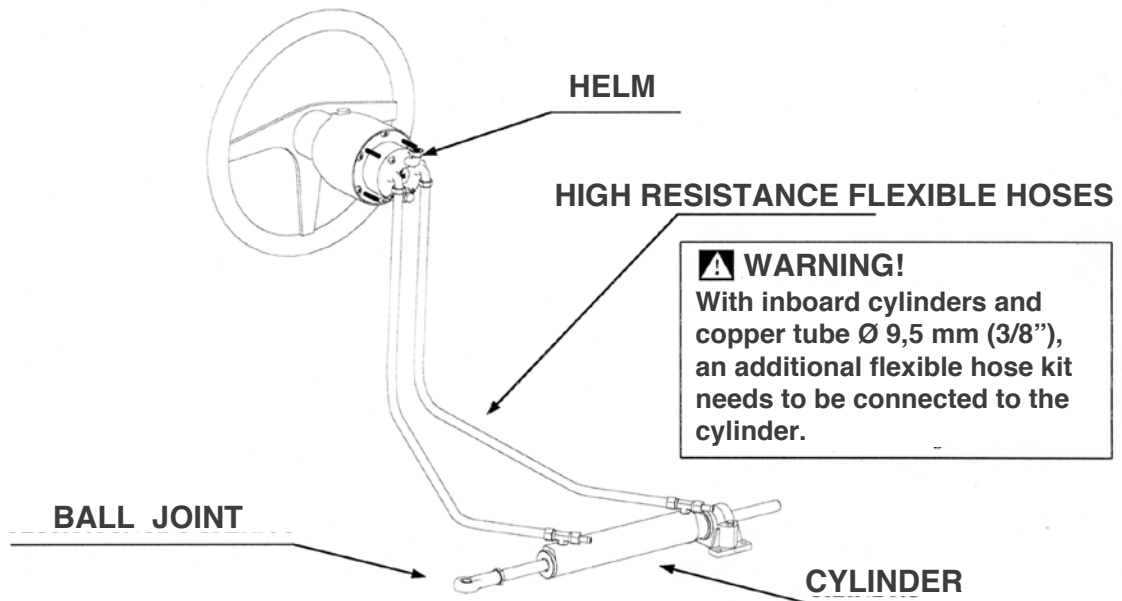

## Dual steering station installation diagram

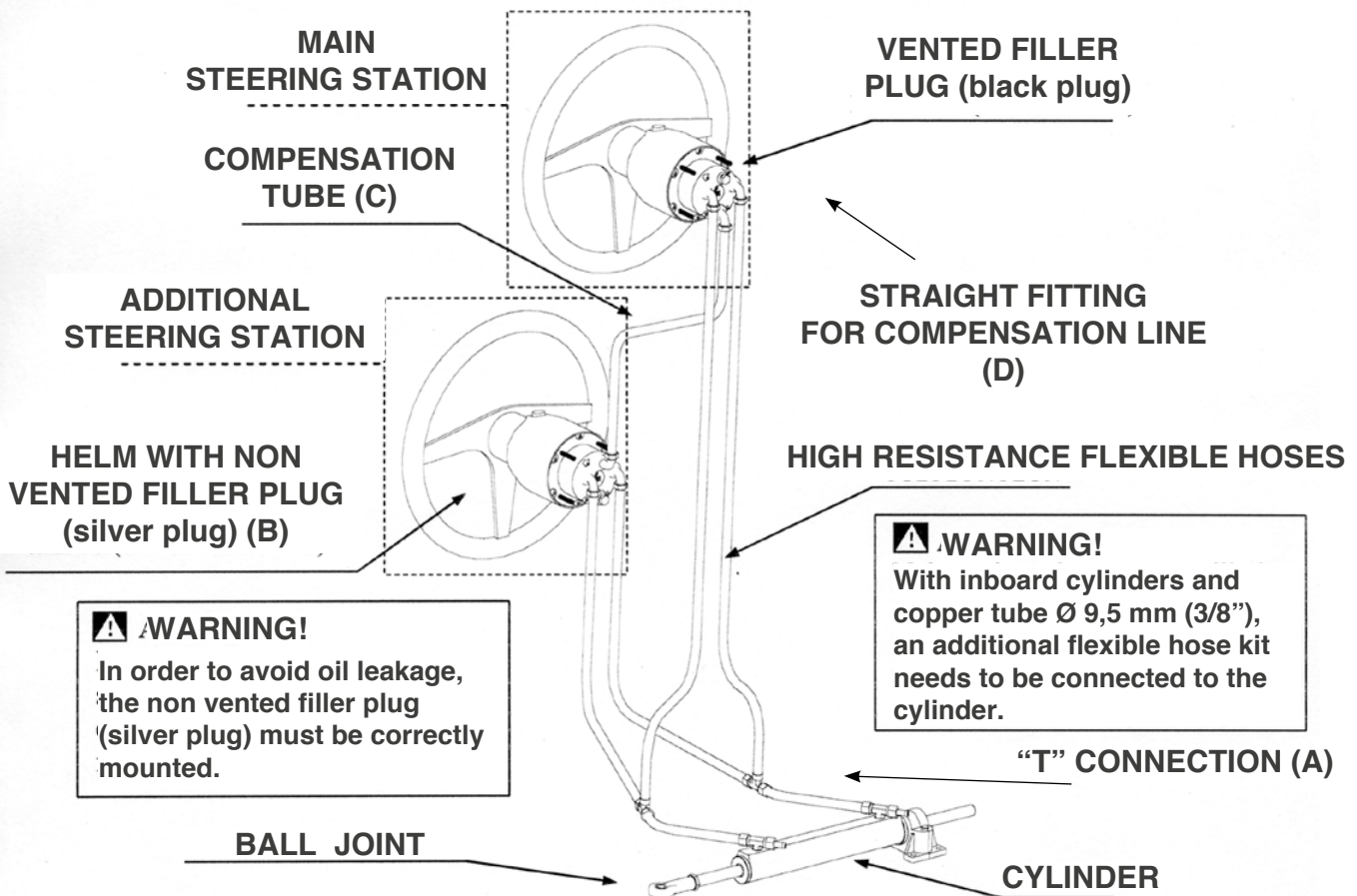

**⚠ WARNING!**  
In order to avoid oil leakage, the non vented filler plug (silver plug) must be correctly mounted.

**⚠ WARNING!**  
With inboard cylinders and copper tube Ø 9,5 mm (3/8"), an additional flexible hose kit needs to be connected to the cylinder.

A) 3/8" T fitting	39502 V
B) non vented filler plug	40802 R
C) TU95 - 3/8" nylon tube (1m)	70701 D
D) SF38 - 3/8" straight fitting	39471 L

Kit OB-2S - 39518 L includes 2xA+B+2xD  
 Kit OB-2S - 43073 X includes 2xA+B+8mxC+2xD

# Inboard steering systems

## Application guide

BOAT LENGTH	UP to 10 m (33')	UP to 10 m (33')	UP to 10 m (33')	10 ÷ 12 m (33' ÷ 40')	10 ÷ 12 m (33' ÷ 40')	12 ÷ 14 m (40' ÷ 46')	14 ÷ 16 m (46' ÷ 53')	16 ÷ 18 m (53' ÷ 59')	18 ÷ 20 m (59' ÷ 66')
<b>CYLINDER</b>									
<b>HELM PUMP</b>	UC69-I	UC116-I	UC168-I	UC215-I	UC293-I	UC339-I	UC378-I	UC442-I	UC530-I
UP18	3,8 N - 3/8"								
UP20	3,5 N - 3/8"								
UP25		4,6 N - 3/8"	6,72 L - 3/8"	8,6 L - 3/8"					
UP28		4,1 M - 3/8"	6 N - 3/8"	7,6 L - 3/8"					
UP33		3,5 H - 3/8"	5,1 M - 3/8"	6,5 N - 3/8"	8,8 L - 3/8"				
UP39			4,3 H - 3/8"	5,5 M - 3/8"	7,5 N - 3/8"	N/A			
UP39-I R				N/A	N/A	8,6 N - R7	9,6 L - R7		
UP45					6,5 M - 3/8"	N/A	N/A		
UP45-I R						7,5 M - R7	8,4 N - R7	9,8 N - R7	11,5 L - R7
UP56						6,0 P - R7	6,7 M - R7	7,9 N - R7	9,5 N - R7
UP68							5,5 P - R7	6,5 M - R7	7,8 N - R7

STEERING WHEEL TURNS LOCK TO LOCK	STEERING WHEEL FEELING	HOSE TYPE
	L=LIGHT	3/8" = 5/16 HOSE AND FITTINGS OR KIT-OB/M
	N=NORMAL	
	M=MEDIUM	R7 = TUR7 FLEXIBLE HOSE AND FR7 FITTINGS
	H=HEAVY	



Photo courtesy of Fluid Motion

**WARNING:** These recommendations should be used as a general reference only. Final selection should be made with the assistance of a qualified installation technician. For any further information please contact our Technical Service

# UP20F - UP25F - UP28F - UP33F - UP39F - UP45F

## Front mount helms



UP20F



UP25F/28F/33F/39F/45F

- Available in six different displacement sizes
- Compact design
- Ball bearing piston race
- Built-in lock valve for positive rudder lock
- Integrated relief valve for over-pressure protection
- 3/4" tapered stainless steel shaft
- Easily accessible lock valve and shaft seal for replacement
- Includes 90° **adjustable** fittings for 3/8" tube
- **X74** - 43048Y square flange for UP20
- **X64** - 40198C square flange (for all models except UP20) or **X57** - 39464P round flange (for all models except UP20) permit to install the pumps in an intermediate dashboard position.



UP20F + X74



UP25F/28F/33F/39F/45F + X64



UP25F/28F/33F/39F/45F + X57

MODEL	P. No.	MOUNTING	DISPLACEMENT/ REVOLUTION	No. OF PISTONS	RELIEF VALVE SETTING	MAXIMUM WHEEL DIA.	WEIGHT
UP20F	43180 Y	Front mount	20 cc - 1.2 cu.in	5	70 Bar - 1000 PSI	508 mm - 20"	3,6 kg - 8 lbs
UP25F	42462 D	Front mount	25 cc - 1.5 cu.in	5	70 Bar - 1000 PSI	710 mm - 28"	5 kg - 11 lbs
UP28F	42459 R	Front mount	28 cc - 1.7 cu.in	5	70 Bar - 1000 PSI	710 mm - 28"	5 kg - 11 lbs
UP33F	42456 J	Front mount	33 cc - 2.0 cu.in	7	70 Bar - 1000 PSI	710 mm - 28"	5 kg - 11 lbs
UP39F	42453 C	Front mount	39 cc - 2.4 cu.in	7	70 Bar - 1000 PSI	710 mm - 28"	5 kg - 11 lbs
UP45F	42465 K	Front mount	45 cc - 2.7 cu.in	7	70 Bar - 1000 PSI	710 mm - 28"	5 kg - 11 lbs

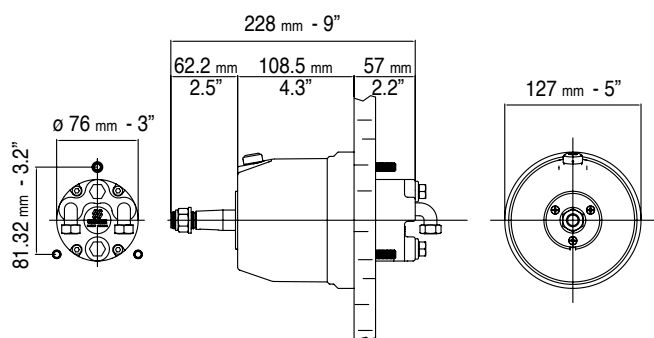

UP25F, UP28F, UP33F, UP39F, UP45F DIMENSIONS

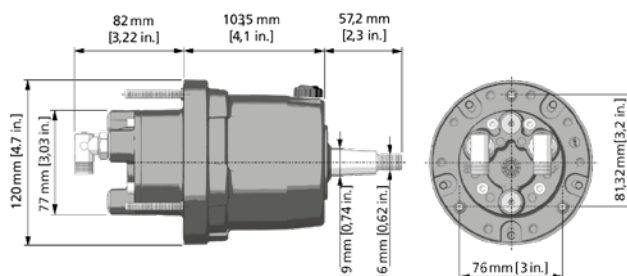

UP20F DIMENSIONS



# UP28R - UP33R - UP39R - UP39-IR - UP45R - UP45-IR

## Rear mount helms



X68

KIT F

- Available in four different displacement sizes
- Compact design
- Ball bearing piston race
- Built-in lock valve for positive rudder lock
- Integrated relief valve for over-pressure protection
- 3/4" tapered stainless steel shaft
- Easily accessible shaft seal for replacement
- Cast iron cylinder rotor for greater durability and longer life
- White bezel included
- Complete with 90° **adjustable** fittings for 3/8" tube, except UP39-I R and UP45-I R pumps (straight fittings for 12 mm hose)
- **X68** (optional) - 40894Z Chrome plated bezel
- **KIT F** (optional) - 39664Y Remote fill adapter

MODEL	P. No.	MOUNTING	DISPLACEMENT/ REVOLUTION	No. OF PISTONS	RELIEF VALVE SETTING	MAXIMUM WHEEL DIA.	WEIGHT
UP28R	42460Z	Rear mount	28 cc - 1.7 cu.in	5	70 Bar - 1000 PSI	710 mm - 28"	5 kg - 11 lbs
UP33R	42457L	Rear mount	33 cc - 2.0 cu.in	7	70 Bar - 1000 PSI	710 mm - 28"	5 kg - 11 lbs
UP39R	42454E	Rear mount	39 cc - 2.4 cu.in	7	70 Bar - 1000 PSI	710 mm - 28"	5 kg - 11 lbs
UP39-IR	42557R	Rear mount	39 cc - 2.4 cu.in	7	70 Bar - 1000 PSI	710 mm - 28"	5 kg - 11 lbs
UP45R	42466M	Rear mount	45 cc - 2.7 cu.in	7	70 Bar - 1000 PSI	710 mm - 28"	5 kg - 11 lbs
UP45-IR	41279H	Rear mount	45 cc - 2.7 cu.in	7	70 Bar - 1000 PSI	710 mm - 28"	5 kg - 11 lbs

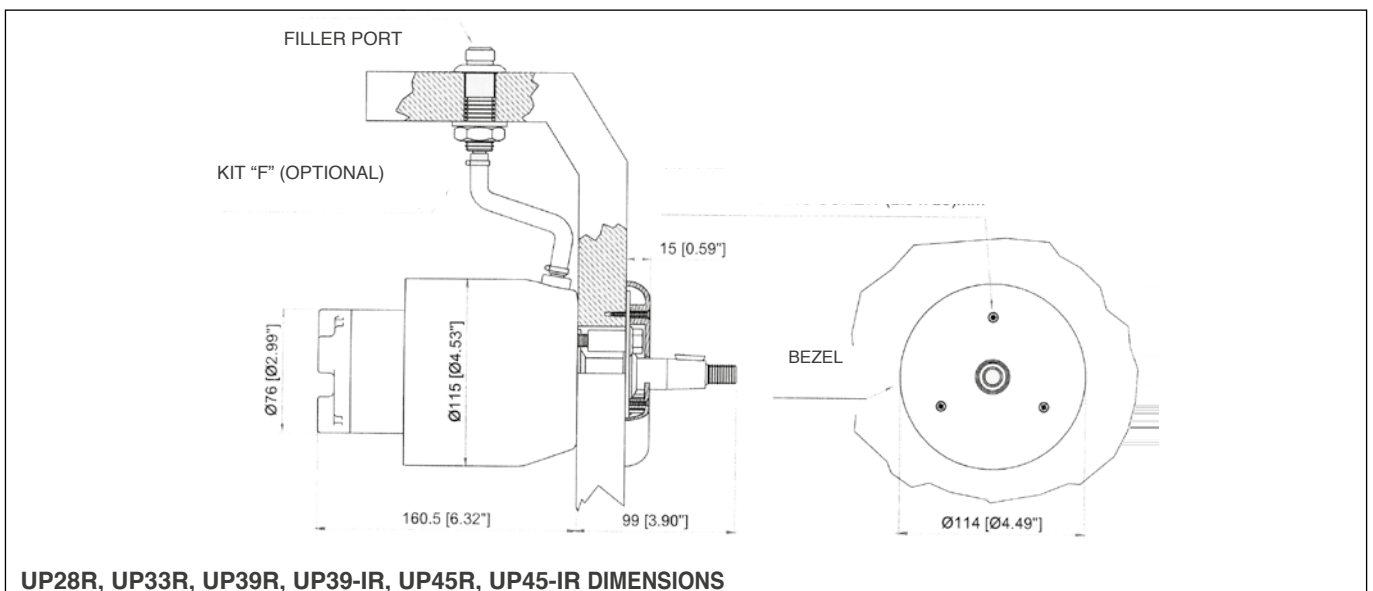

UP28R, UP33R, UP39R, UP39-IR, UP45R, UP45-IR DIMENSIONS



## UP56 - UP68

### Rear or intermediate mount helms



KIT F56



KR56



- Rear or intermediate mounting configuration
- Ball bearing piston race
- Built-in lock valve for positive rudder lock
- 3/4" tapered shaft
- Easily accessible shaft seal for replacement
- Brass rotor for greater durability and longer life
- 3/8" BSPP fitting for 12 mm tube
- Complete with fittings
- **KR56** (optional) - 42558T permits to install the UP56 and UP68 pumps in a rear mount position. Includes chrome plated cover ring.
- **KIM56** (optional) - 42559V hardware kit: permits to install the UP56 and UP68 pumps in an intermediate mount position

**NOTE:** UP56 or UP68 installation needs either kit KR56 or KIM56

- **KIT F56** (optional) - 40813W Remote fill adapter

MODEL	P. No.	MOUNTING	DISPLACEMENT/ REVOLUTION	No. OF PISTONS	RELIEF VALVE SETTING	MAXIMUM WHEEL DIA.	WEIGHT
UP56	40808D	Rear (KR56) - Intermediate (KIM56)	56 cc - 3.4 cu.in	7	70 Bar - 1000 PSI	710 mm - 28"	7,5 kg - 16,5 lbs
UP68	42561F	Rear (KR56) - Intermediate (KIM56)	68 cc - 4.15 cu.in	7	70 Bar - 1000 PSI	710 mm - 28"	7,5 kg - 16,5 lbs

### RV70 - 42560D - Relief valve 70 bar

**WARNING:** Applications with UP56 or UP68 pumps require the RV70 relief valve added to the system for over-pressure protection.



RV70

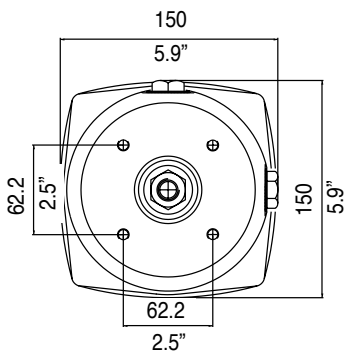

UP56, UP68

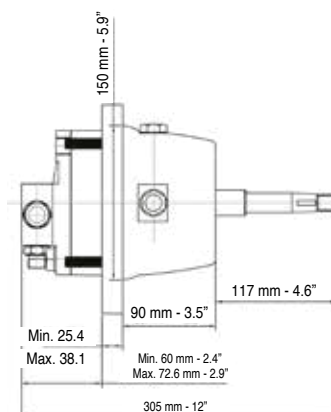

UP56, UP68 INTERMEDIATE MOUNT

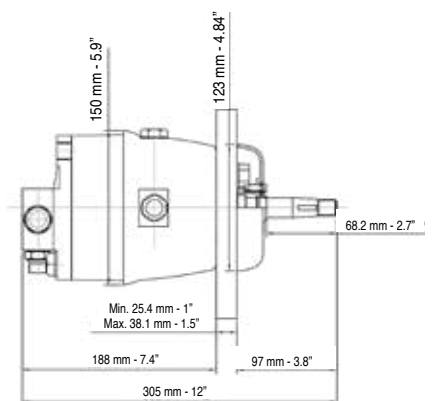

UP56, UP68 REAR MOUNT

# UC69-I - UC116-I - UC168-I - UC215-I Inboard cylinders



**UC69-I** - Balanced: the number of turns lock-to-lock is equal port to starboard or vice-versa.



**UC116-I; UC168-I; UC215-I**  
All balanced cylinders: the number of turns lock-to-lock is equal port to starboard and vice-versa

SPECIFICATIONS	UC69-I - 39782E	UC116-I - 39431Y Alluminium	UC168-I - 39432A Alluminium	UC215-I - 39433C Alluminium
Volume	69 cc - 4.2 cu. in	116 cc - 7 cu. in	168 cc - 10.25 cu.in	215 cc - 13.12 cu. in
Torque	32 kgm - 2783 lbs. in	58 kgm - 5043 lbs. in	87 kgm - 7565 lbs. in	111 kgm - 9652 lbs. in
Output force	168 kg - 371 lbs	464 kg - 1023 lbs	673 kg - 1483 lbs	673 kg - 1483 lbs
Internal diameter	25 mm - 0.98"	32 mm - 1.25"	40 mm - 1.57"	40 mm - 1.57"
Stroke	150 mm - 5.9"	178 mm - 7"	178 mm - 7"	228 mm - 9"
3/8" (9,5 mm) Fittings	For high pressure flex hose	For high pressure flex hose	For high pressure flex hose	For high pressure flex hose

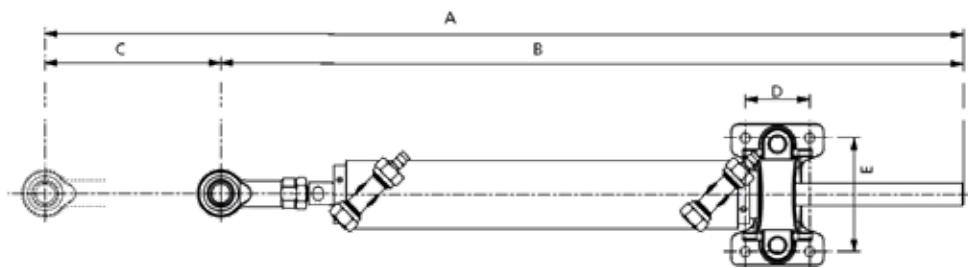

	UC69-I	UC116-I	UC168-I	UC215-I
<b>A</b>	644 mm - 25.33"	741 mm - 29.17"	792 mm - 31.18"	941 mm - 37.05"
<b>B</b>	494 mm - 19.43"	563 mm - 22.17"	614 mm - 24.17"	713 mm - 28.07"
<b>C (stroke)</b>	150 mm - 5.9"	178 mm - 7"	178 mm - 7"	228 mm - 8.98"
<b>D</b>	40 mm - 1.57"	40 mm - 1.57"	40 mm - 1.57"	40 mm - 1.57"
<b>E</b>	73 mm - 2.87"	73 mm - 2.87"	105 mm - 4.13"	105 mm - 4.13"
<b>Rod Ø</b>	14 mm - 0.55"	14 mm - 0.55"	20 mm - 0.79"	20 mm - 0.79"

## UC293-I - UC378-I Inboard cylinders



### UC293-I; UC378-I

Balanced: the number of turns lock-to-lock is equal port to starboard or vice-versa.

SPECIFICATIONS	UC293-I - 40246L Brass	UC378-I - 40810P Brass
Volume	293 cc - 17.8 cu. in	376 cc - 22.94 cu. in
Torque	146,5 kgm - 12816 lbs. in	187,6 kgm - 16347 lbs. in
Output force	1155 kg - 2545 lbs	1155 kg - 2545 lbs
Internal diameter	50 mm - 1.97"	50 mm - 1.97"
Stroke	178 mm - 7"	228 mm - 9"
Fittings	3/8" (9,5 mm) for high pressure flex hose	for (12 mm) copper tube (flexible connection hoses not included) or TUR7 high pressure flex hose

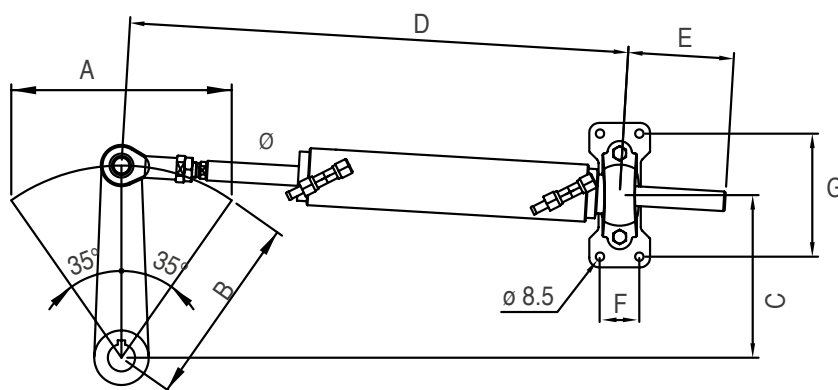

	UC293-I	UC378-I
A	178 mm - 7"	228 mm - 9"
B	163 mm - 6.4"	199 mm - 7.8"
C	134 mm - 5.2"	163 mm - 6.4"
D	506 mm - 19.9"	592 mm - 23.3"
E	107 mm - 4.2"	132,5 mm - 5.2"
F	40 mm - 1.6"	40 mm - 1.6"
G	125 mm - 4.9"	125 mm - 4.9"
Rod Ø	20 mm - 0.8"	20 mm - 0.8"

# UC339-I - UC442-I - UC530-I Inboard cylinders



## UC339-I; UC442-I

Balanced: the number of turns lock-to-lock is equal port to starboard or vice-versa.



## UC530-I

Balanced: the number of turns lock-to-lock is equal port to starboard or vice-versa.

SPECIFICATIONS	UC339-I 42562H	UC442-I 42563K	UC530-I 42564M
Volume	339 cc – 20.7 cu.in	442 cc – 26.9 cu.in	530 cc – 32.3 cu.in
Torque	172 kgm – 14957.7 lbs.in	223 kgm – 19335.6 lbs.in	270 kgm – 23443.4 lbs.in
Output force	1051 kg – 2316.6 lbs	1051 kg – 2316.6 lbs	1513 kg – 3335.9 lbs
Inside diameter	50 mm – 1.97"	50 mm – 1.97"	60 mm – 2.36"
Stroke	230 mm – 9"	300 mm – 12"	250 mm – 10"
Fittings	For 12 mm copper tube or TUR7 high pressure flex hose	For 12 mm copper tube or TUR7 high pressure flex hose	For 12 mm copper tube or TUR7 high pressure flex hose

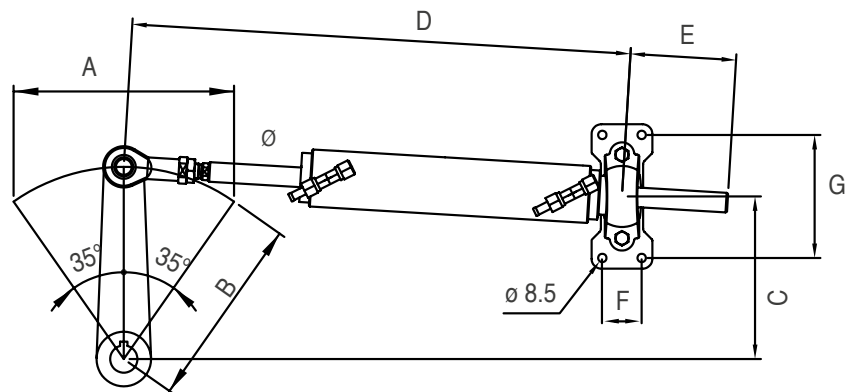

	UC339-I	UC442-I	UC530-I
A	230 mm – 9"	300 mm – 12"	250 mm – 10"
B	200 mm – 7.9"	260 mm – 10.2"	218 mm – 8.6"
C	164 mm – 6.5"	212 mm – 8.3"	178 mm – 7.0"
D	637 mm – 25.1"	749 mm – 29.5"	723 mm – 28.5"
E	147 mm – 5.8"	183 mm – 7.2"	168 mm – 6.6"
F	70 mm – 2.8"	70 mm – 2.8"	120 mm – 4.7"
G	110 mm – 4.3"	110 mm – 4.3"	104 mm – 4.1"
Rod Ø	25 mm – 0.98"	25 mm – 0.98"	30 mm – 1.18"

## Hoses - accessories - fittings

<b>TU5/16</b>	5/16" nylon tubing for OB-F5/16 fittings. Available per metre and 164 ft (50 m) coils.
<b>OB-F5/16 - 40849U</b>	reusable fitting featuring turning nut for use with 5/16" hydraulic hose and connection for 3/8" end fitting.
<b>TUR7</b>	high pressure hydraulic hose for FR7 12 mm end fittings. Available per metre and 164 ft (50 m) coils.
<b>FR7 - 42569Y</b>	1 reusable fitting for use with 3/8" hydraulic hose and connection with 12 mm helm and cylinder fittings.
<b>RV70 - 42560D</b>	relief valve required for use in inboard applications with UP56 and UP68 pumps.
<b>KIT OB-2S - 43183E</b>	fitting kit for a second steering station or for an autopilot installation. It includes: - (25') TU 95 Tubing - (1) 40800L - Non Vented Cap - (2) CONNECTOR FITT. - 1/4npt to 3/8 straight fitting - (2) UNION T - 3/8" Tube Brass T Fitting
<b>KIT 95 - 39516G</b>	3/8" copper tube fitting kit. It includes one 3.2 ft (1 m) nylon tube and all necessary fittings for a single station application.
<b>KIT 120-I - 42765Y</b>	12 mm copper tube fitting kit – It includes one 3.2 ft (1 m) nylon tube and all necessary fittings for a single station application

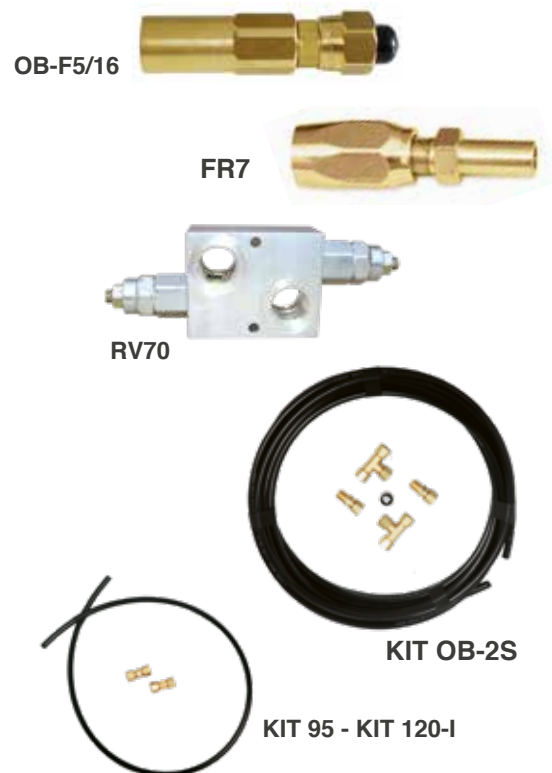

## ACCESSORIES

**KIT 95-2S - 43184G:** fitting kit for a second steering station or for an autopilot installation. It includes:

- (1) 40800L - Non Vented Cap
- (2) CONNECTOR FITT. - 1/4npt to 3/8 straight fitting
- (2) UNION T - 3/8" Tube Brass T Fitting

**KIT 120U-2S - 41625A:** fitting kit for a second steering station or for an autopilot installation. It includes all necessary fittings for 12 mm flexible hose or copper tube in UP33-I R or UP45-I R applications.

**KIT 120-2S - 40821V:** fitting kit for a second steering station or for an autopilot installation. It includes all necessary fittings for 12 mm flexible hose or copper tube in UP56 or UP68 applications.

**OIL 15 - 70704K:** Hydraulic oil sold in 0.26 gallons (1 litre) bottle

**OIL 15 55D:** Hydraulic oil sold in 55 gallon drum

- hydraulic oil: 150 VG 15
- solidification point: < -30°C
- contamination according to NAS1638 ≤ 8

**KIT F - 39664Y:** remote fill adapter for rear mount UP28, UP33, UP39, UP45 pumps.

**KIT F56 - 40813W:** remote fill adapter for rear mount UP56 and UP68 pumps.

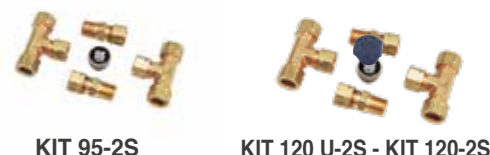

KIT 95-2S

KIT 120 U-2S - KIT 120-2S



OIL 15



KIT F - KIT F56 (adapter included)

Model	Description	Typical Application	Thread
<b>AF45</b> 41284A	 45 DEGREE ADJUSTABLE FITTING	Fitting for the back of the UP series helms	"ORB, Size #6 to 3/8 COMP FITTING" Helm Side = 9/16 - 18 UNF 2A Hose Side = 9/16 - 24 UNEF 2A
<b>AF90</b> 74144U	 90 DEGREE ADJUSTABLE FITTING	Fitting for the back of the UP series helms	"ORB, Size #6 to 3/8 COMP FITTING" Helm Side = 9/16 - 18 UNF 2A, Hose Side = 9/16 - 24 UNEF 2A
<b>71928P</b>	 BRASS PLUG W/ORING FOR PUMPS	Compensating line brass plug of the UP series helms	"1/4 NPT PLUG" Helm Side = 1/4 NPT
<b>SF18</b> 43179P	 STRAIGHT HELM FITTING 1/8 NPT	Fitting for the compensating line in the UP series helms or autopilot return line	-
<b>SF38</b> 39471L	 STRAIGHT HELM FITTING 1/4 NPT	Fitting for the compensating line in the UP series helms or autopilot return line	"1/4 NPT to 3/8 COMP FITTING" Helm Side = 1/4 NPT Hose Side = 9/16 - 24 UNEF 2A
<b>EF38</b> 39472N	 90° HELM FITTING FOR UP SERIES	Fitting for port / starboard line in the UP series helms prior to the boss fittings	"1/4 NPT to 3/8 COMP FITTING" Helm Side = 1/4 NPT Hose Side = 9/16 - 24 UNEF 2A
<b>71955T</b>	 BOSS STYLE T-FITTING NICKEL	Fitting for back of helm in a dual station installation	"ORB, Size #6 to 3/8 COMP FITTING" Cylinder/Helm Side = 9/16 - 18 UNF 2A Hose Side = 9/16 - 24 UNEF 2A
<b>T-FITTING</b>	 1/4 NPT TO 3/8 T-FITTING	Fitting used in the back of the previous version of the UP series helms before the boss fitting	"1/4 NPT to 3/8 COMP FITTING" Helm/Side = 1/4 NPT Hose Side = 9/16 - 24 UNEF 2A
<b>VFNO38</b> 40868Y	 COMPLETE BOSS FITTING UC128OBF	Bleed fitting for all outboard cylinders	"ORB, Size #6 to 3/8 COMP FITTING" Cylinder Side = 9/16 - 18 UNF 2A Hose Side = 9/16 - 24 UNEF 2A
<b>71861H</b>	 T-FITTING ASSEMBLY-ORF HOSE	Used to replace the boss fitting in new outboard cylinders when trying to connect 'O' ring face seal hoses	"ORB, Size #6 to 3/8 COMP FITTING" Cylinder Side = 9/16 - 18 UNF 2A Hose Side = 9/16 - 24 UNEF 2A
<b>VFN38</b> 39925A	 TEE FITTING WITH BLEED NIPPLE	Bleed fitting for all inboard and stern drive cylinders	"1/4 NPT to 3/8 COMP FITTING" Cylinder Side = 1/4 NPT Hose Side = 9/16 - 24 UNEF 2A
<b>TF38</b> 39502V	 UNION T-FITTING FOR 3/8" TUBE	T-Fitting for 3 standard 3/8" compression thread hose fittings	"3/8 COMP FITTING" ALL Sides = 9/16 - 24 UNEF 2A
<b>61BCA</b> 71004K	 BRASS NUT W/SLEEVE #61CA-6	3/8" Compression Nut with ferrule for cut to length nylon tubing	"3/8 COMP NUT" Side = 9/16 - 24 UNEF 2B Hose Side = 3/8 Compression Ferrule
<b>UNION</b> 62CA-6	 UNION 3/8 IN COMPRESSION	Used to connect 2 standard 3/8" Compression hoses	"3/8 COMP FITTING" Both Sides = 9/16 - 24 UNEF 2A
<b>MD 38 NI</b> COM FT	 90° 3/8 NI PLATE COMP FITTING	90° fitting from bulkhead fitting to 3/8" compression hose	"3/8 COMP FITTING" Fitting side = 9/16 - 24 UNEF 2B Hose Side = 9/16 - 24 UNEF 2A
<b>Q22</b> 898366	 TAPERED HELM FITTING TO MERCURY 'O' RING	Fitting for the back of the Merc UP series helms to 'O' ring face seal Hoses	1/4 NPT to ORFS Fitting Side = 1/4 NPT Hose Side = ORFS ('O' rin Face)
<b>UPS 11/16</b> ELBOW	 POWERTECH 11/16, 90 DEG ELBOW	90° fitting for the pressure and tank line on a poertech helm	-
<b>UPS 90 DEG</b> ELB	 POWERTECH 90 DEGREE ELBOW	90° fitting for the two high pressure outlets on a powertech helm/also used for connection from a bulkhead	-
<b>UPS BLKHD</b> T-FIT	 POWERTECH BULKHEAD T-FITTING	T-Fitting used on bulkhead fittings or helm high pressure lines on powertech helm	-
<b>UPS</b> T-FITTING	 POWERTECH T-FITTING	3-wat ORF fitting for Mercury style ORF hoses	-
<b>UPS UNION</b>	 POWERTECH UNION FOR KITPS/PSDS	11/16" union to extend a KITPS/KITPSDS hose	-
<b>UPS UNION</b> OB	 POWERTECH UNION FOR KITOBPS	ORF to ORF union for connection of high pressure ORF style hoses	-
<b>UPS 4-4</b> FLO-SS	 POWERTECH MALE CONNECTOR	Used when connecting an Autopilot to Powertech System - Autopilot to ORF Hose	-



# Masterdrive™

## Power assisted inboard steering system



MD – Packaged kit for single station

### System features

- Eliminates torque at the steering wheel
- Three different selectable levels of power give the boater the desired feeling on the wheel (PATENTED).
- Automatically reverts to manual mode in case of power loss.
- High efficiency, low Amp draw
- The system always running permits immediate control in any sea conditions
- Equipped with safety switch ON/OFF (SMART BUTTON)
- Can be used on dual station installations
- Suitable for use with autopilot
- Low noise
- Voltage: 12VDC
- CE marked in conformity with ABYC P21, ISO 10592 safety standards
- Ignition protected (SAE J-1171 and UNI EN 28846)

### System components

- 1 single packaged KIT MD containing:
  - 1 **UH**-front or tilt mount Main Helm
  - 1 **UPMD** Power Unit, 15' (4,5 m) wiring harness included
  - 1 **UCMD** User Interface
  - 4 **OIL 15** bottles of hydraulic oil
- 1 inboard cylinder (suggested model: see "order guide" next page)
- 1 **KIT MD2**: for dual station
- Flexible hydraulic hoses
- 1 Tilt mechanism **X88** - 44006L suitable for Tilt Mount Helm. Tilt range of 48° and five locking positions.
- 1 Dual cylinder application Tie Bar: see selection
- 1 Steering Wheel: see selection
- 1 Instruction manual

### Note

The MasterDrive helms (both the UH Main and the UHD secondary for a dual station), the UPMD Power Unit and the UCMD User Interface are the same products shown on the outboard MasterDrive system. For more details please refer to the outboard MasterDrive section.



## Order guide

SINGLE CYLINDER APPLICATION					
Kit MasterDrive™	Cylinder	Wheel turns	Max Rudder torque	Connection flex hoses	Steering wheel
MD32-F - 42098J	UC116 - 39431Y	3,6	52 kgm 5043 lbs. in	2 kit OB-SVS (length selection)	1 steering wheel
MD32-F - 42098J	UC168 - 39432A	5,2	87 kgm 7565 lbs. in		
MD32-F - 42098J	UC215 - 39433C	6,7	111 kgm 9642 lbs. in		
MD40-F - 42102W	UC215 - 39433C	5,3	111 kgm 9642 lbs. in		
MD40-F - 42102W	UC293 - 40246L	7,3	146,5 kgm 12816 lbs. in		

DUAL CYLINDER APPLICATION					
MD32-F - 42098J	2 UC116 - 39431Y	7,2	52 kgm 5043 lbs. in	2 kit OB-SVS (length selection)	1 steering wheel
MD40-F - 42102W	2 UC168 - 39432A	8,4	87 kgm 7565 lbs. in	1 kit OB-DBR130-SVS (length selection)	

**NOTE:** On tilt applications, replace MD32-F or MD40-F MasterDrive kit with MD32-T or MD40-T kit + tilt mechanism X66 (optional).

Wheel selection: please refer to the appropriate section.

**For a second station add:**

1 Kit MD (select kit required by the needed installation)

3 Kit OB-SVS (select length required)

**NOTE:**

On request, Power Unit wiring harness can be cut to length required.

**7 m (23 ft) panel extension cable also available - 42636L**

## Inboard steering systems order guide

PUMP model	CYLINDER model	Wheel turns Lock-to-lock	Max rudder torque	Flex hose or copper tube	Kit for a dual station installation
UP25F	UC116-I	4.6	58 kgm 5043 lbs.in.	TU5/16 flex hose or 3/8" copper tube	KIT-OB-2S 39539V or Kit 95-2S 39518L
UP28F or UP28R	UC116-I	4.1	58 kgm 5043 lbs.in.	TU5/16 flex hose or 3/8" copper tube	KIT-OB-2S 39539V or Kit 95-2S 39518L
UP28F or UP28R	UC168-I	6.0	87 kgm 7565 lbs.in.	TU5/16 flex hose or 3/8" copper tube	KIT-OB-2S 39539V or Kit 95-2S 39518L
UP33F or UP33R	UC168-I	5.1	87 kgm 7565 lbs.in.	TU5/16 flex hose or 3/8" copper tube	KIT-OB-2S 39539V or Kit 95-2S 39518L
UP33F or UP33R	UC215-I	6.5	111 kgm 9642 lbs.in.	TU5/16 flex hose or 3/8" copper tube	KIT-OB-2S 39539V or Kit 95-2S 39518L
UP39F or UP39R	UC215-I	5.5	111 kgm 9642 lbs.in.	TU5/16 flex hose or 3/8" copper tube	KIT-OB-2S 39539V or Kit 95-2S 39518L
UP39F or UP39R	UC293-I	7.5	146,5 kgm 12816 lbs.in.	TU5/16 flex hose or 3/8" copper tube	KIT-OB-2S 39539V or Kit 95-2S 39518L
UP45F or UP45R	UC293-I	6.5	146,5 kgm 12816 lbs.in.	TU5/16 flex hose or 3/8" copper tube	KIT-OB-2S 39539V or Kit 95-2S 39518L
UP56* with KR56 or KIM56	UC339-I	6.0	172 kgm 14958 lbs.in	12mm copper tube or TUR7 flex hose	KIT120-2S 40821V
UP56* with KR56 or KIM56	UC378-I	6.7	187,6 kgm 16347 lbs.in.	12mm copper tube or TUR7 flex hose	KIT120-2S 40821V
UP56* with KR56 or KIM56	UC442-I	7.9	223 kgm 19336 lbs.in	12mm copper tube or TUR7 flex hose	KIT120-2S 40821V
UP68* with KR56 or KIM56	UC442-I	6.5	223 kgm 19336 lbs.in	12mm copper tube or TUR7 flex hose	KIT120-2S 40821V
UP68* with KR56 or KIM56	UC530-I	7.8	270 kgm 23443 lbs.in	12mm copper tube or TUR7 flex hose	KIT120-2S 40821V

\* **WARNING:** Applications with UP56 or UP68 pumps require the RV70 - 42560 D relief valve added to the system for over-pressure protection.



**Integra™ EPS**  
Inboard electronic power steering systems

# INTEGRA EPS

**new**

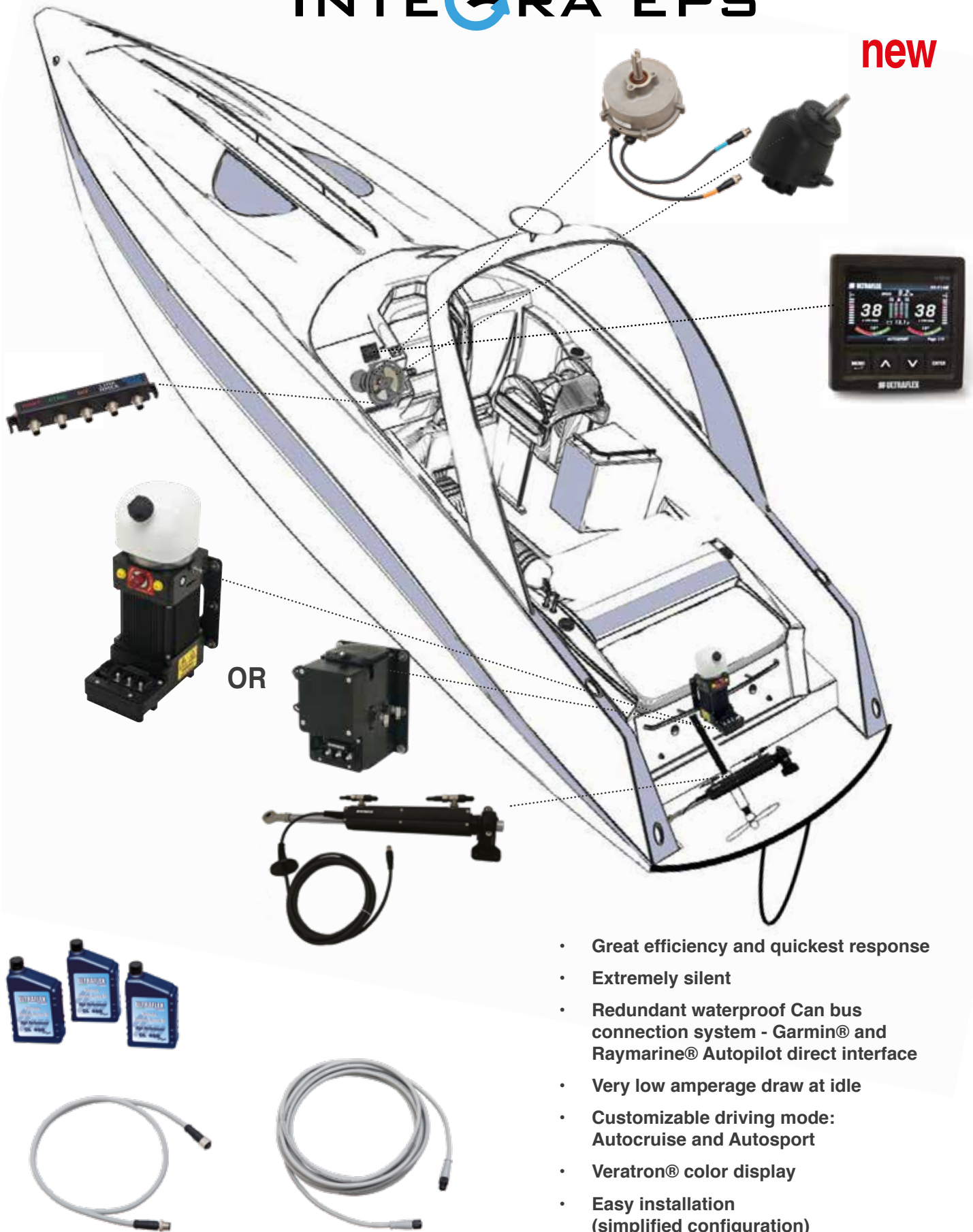

- Great efficiency and quickest response
- Extremely silent
- Redundant waterproof Can bus connection system - Garmin® and Raymarine® Autopilot direct interface
- Very low amperage draw at idle
- Customizable driving mode: Autocruise and Autosport
- Veratron® color display
- Easy installation (simplified configuration)



# INTEGRA JS

new



- Integra JS adds to Integra EPS functionalities a new level of manoeuvrability, thanks to the Joystick technology.
- Integra JS is a more intuitive way of driving. Designed for low speed manoeuvring the joystick grants precision and driving comfort and facilitates docking and trailer procedures as the boat can move sideways, diagonally or spin on its own axis
- Includes Boost, Heading, Anchor, Mainstay and Trim function





# Integra™

## Inboard electronic power steering systems

Model	UIP	UIPC
Operating voltage	10,8 V - 14,4 V	
Average current draw	5 A	2 A
Temperature range	-25°C / +77°C	
Nominal voltage	12 VDC	
Max flow	4,8 l/min @ 60 bar (cw & ccw)	4,0 l/min @ 50 bar
Relief valve	120 bar - 1740 PSI	105 bar - 1500 PSI
Pump unit motor	12 VDC Brushless	
Outboard engine installations	Single, dual, triple or quad	
N. of engines per motor pump unit	up to 4	up to 2
Autopilot direct interface	Garmin® Raymarine® Furuno® Simrad®	
Customizable Driving mode	Autocruise and Autosport	
Customizable wheel effort	Yes	
Exceeds Safety Standards	ISO 25197, ISO 10592, ABYC P21, P24, P27	
Ignition Protected SAE J1171	Yes	

System components	Integra EPS™	Integra JS™
UIH - Tilt mount electronic helm	✓	✓
UJS-B Integra JS joystick	-	✓
UGW-D - Digital Integra JS Gateway	-	✓
UGW-A - Analogic Integra JS Gateway	-	✓
X82 - Adjustable steering wheel tilt mechanism	✓	✓
UID - Veratron®-VDO® color display	✓	✓
BCM - Body Control Module – CAN Bus network module	✓	✓
UIP - High Power electro-hydraulic power unit	✓	✓
UIPC - Compact electro-hydraulic power unit	✓	✓
UC120E - Heavy duty starboard cylinder with integrated sensor	✓	✓
UC120EP - Heavy duty port cylinder with integrated sensor		
Tie bar - Please refer to Integra tie bar section	✓	✓
KIT OB-SVS - High pressure Hydraulic hoses with pre crimped fittings	✓	✓
CAN Bus wires - Can Bus power wires	✓	✓
KBD3 - Purging kit with twin spiralled hoses and connectors (optional)	✓	✓
OL460 - 3 one litre hydraulic oil bottles (single bottle - 436467V)	✓	✓

### Integra EPS and Integra JS key benefits

- **Redundant electronic steering system**, a reliable way to reduce steering effort, tuning your driving and enhancing steering experience.
- **Powerful output, great efficiency and quickest response** in any situation, thanks to the brushless motor of the pump unit and to the electronic management
- **Extremely silent**
- **Low amperage system**
- **Veratron® colour display**
- **Customizable driving mode:** the user can choose between Autocruise and Autosport driving mode
- **Autopilot direct interface:** **Garmin®** Reactor™ 40 Steer-by-wire, **Raymarine®** EV-2 SBW, **Furuno®** Navipilot 300, **Simrad®** AP44 e Ap48 con NAC-D
- **Easy installation**, thanks to the simplified configuration and the CAN bus connection system.
- **Customizable wheel effort.**
- Wheel effort is programmed to change with engine RPM.
- **Tilt range of 48° and 5 locking positions**, thanks to the **X82** tilt mechanisms
- **Easy boat handling**, thanks to the adjustable speed sensitive turns lock to lock
- **The pump unit** is available in **2 versions** to choose from, based on the selected application: **UIP** (High Power electro-hydraulic power unit) and **UIPC** (Compact electro-hydraulic power unit) and **can be positioned anywhere** on the boat
- It's possible to have a no tie-bar configuration, using two motor pump units
- **Automatic Power Selector** to ensure optimal voltage
- Designed for single, dual, triple or quad outboard engines
- Available for multiple steering stations applications
- It can handle up to 4 engines with a single power unit
- Heavy duty steering cylinder with embedded CAN bus position sensor

### Integra JS additional functionalities

- **Integra JS** adds to Integra EPS functionalities a new level of manoeuvrability, thanks to the **Joystick technology**
- **Integra JS** is a more **intuitive way of driving**. Designed for **low speed maneuvering**, the Joystick guarantees precision and driving comfort.
- **Integra JS Joystick** includes several functions: **Boost** function used to momentarily increase engine rpm if you need instant thrust, **Heading** function, that gives the ability to maintain the set course, **Anchor** function, to maintain boat position via GPS connection and **MainStay** the combination of the previous functions (**Heading** and **Anchor**). **Anchor, Heading and MainStay** functions needs the presence of **Veratron® Nav Sensor - 20201Z**

# Integra™

## Inboard electronic power steering systems

### UIH1 - Electronic helm

- Electronic steering helm tilt mount **X82** -43817N
- Easy to install, no oil or hydraulic hoses

**UIH1** - 43536M - first station electronic helm.

**UIH2** - 43537P - second station electronic helm

**UIH3** - 43538S - third station electronic helm

- Resistant to harsh marine conditions
- Steering wheel turns can be set by the user.
- Variable steering wheel resistance according to boat speed
- Instant responsiveness
- Redundant architecture with 2 CAN bus channels



**X82**



**UIH1**

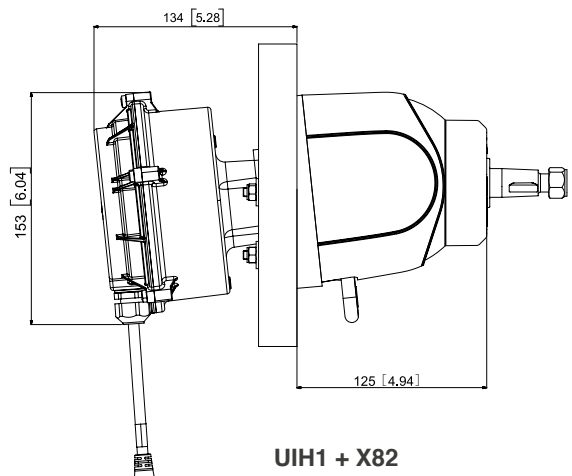
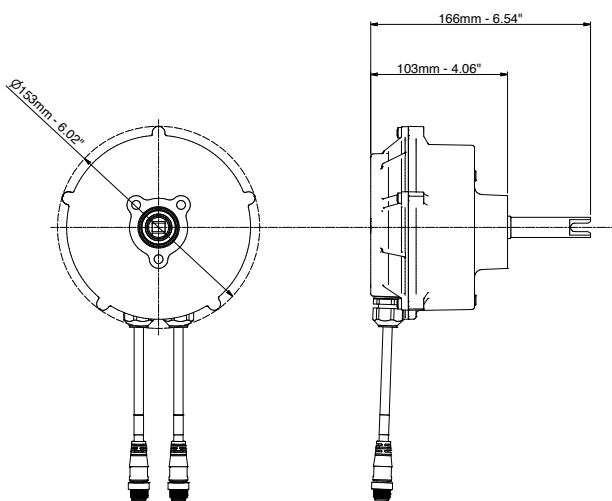

**UIH1 + X82**

## UJS - B Integra JS joystick with Bow Thruster

- Power: turning on the station
- BOOST switch on the handle: momentarily increases engine rpm if you need instant thrust, it is active as long as the switch is pressed
- Signal lights: indicate if the joystick is in Neutral or the set direction
- **Thruster only**: operate bow thruster only
- **Heading**: ability to maintain the set course
- UP and Down trim keys: to be connected to the boat's trims
- **Anchor** function allows boat position to be maintained via GPS connection
- **MainStay** function is activated by pressing the **Heading** and **Anchor** keys  
Anchor, Heading and MainStay function requires Veratron® Nav Sensor - part number 20201Z
- CAN Bus communication via 2 DeviceNet® connectors.

<b>UJS-B1</b>	44162B	Integra JS joystick first station with Bow Thruster
<b>UJS-B2</b>	44163D	Integra JS joystick second station with Bow Thruster

new



UJS-B

## BCM (Body Control Module) - Can Bus Network Module

- Waterproof CAN bus connection system
- Direct interface with Garmin®, Raymarine®, Simrad® and Furuno® autopilot
- Very compact dimensions

<b>BCM</b>	43540C	Can Bus network module
------------	--------	------------------------



BCM

# Integra™

## Inboard electronic power steering systems

### UGW- Gateway

Device to control throttle and inverter in Honda, Suzuki and Selva outboard engines. It allows management of the trims directly from the joystick.

#### UGW- D Digital Gateway

UGW-D	43934A	Digital Gateway
UGWD-S1	43991N	Harness for UGW-D digital gateway and Suzuki engines equippe with
UGWD-S2	43990L	Harness for UGW-D digital gateway and Suzuki engines equippe with
UGWD-H1	43990L	Harness for UGW-D digital gateway and Honda engines

#### UGW- A Analogic Gateway

UGW-A	43985U	Analog Gateway
UGWA-H2	44083F	Harness for UGW-A analog gateway and Honda engines



UGW

### UID - Veratron® color display

- Veratron® **color Display** - user adjustable brightness
- **Customizable driving mode:** the user can choose between **Autocruise** and **Autosport** driving mode
- **Customizable wheel effort.**
- **Automatic wheel effort setting** with engine RPM
- Multiple steering station applications
- Electronic anchor response level setting

UID - B	43539U	UID Veratron® display - black
UID - W	43825V	UID Veratron® display - white



UID

#### Display visual information:

- Boat speed
- Engine RPM
- Engine temperature
- Rudder angle display
- Trim angle display
- Fuel level
- Battery voltage
- Percentage operation bow thruster



## UIP and UIPC - Power units

- 12 VDC brushless motor
- High power: very short lead times for maximum reactivity
- Embedded automatic power selector to manage the power supply from 2 batteries
- Can be installed anywhere on the boat
- 90° swiveling fittings for easy hose connection
- Tank: 1 litre (0.26 gal) UIP power unit; 0,3 litres (0.08 gal) UIPC power unit
- Vented cap
- Marine anodized aluminum body
- Include the main connector with 1m communication cables
- Ignition Protected SAE J1171



UIPC



UIP

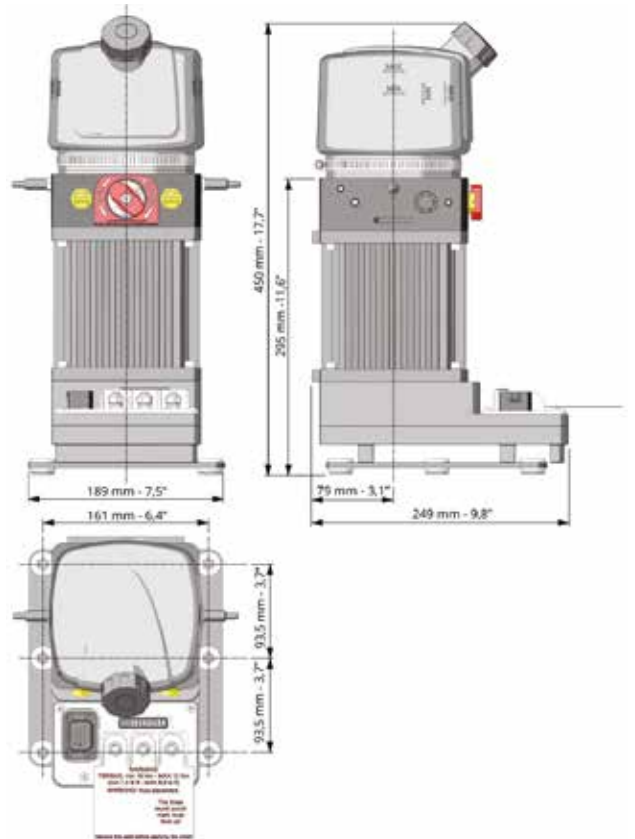
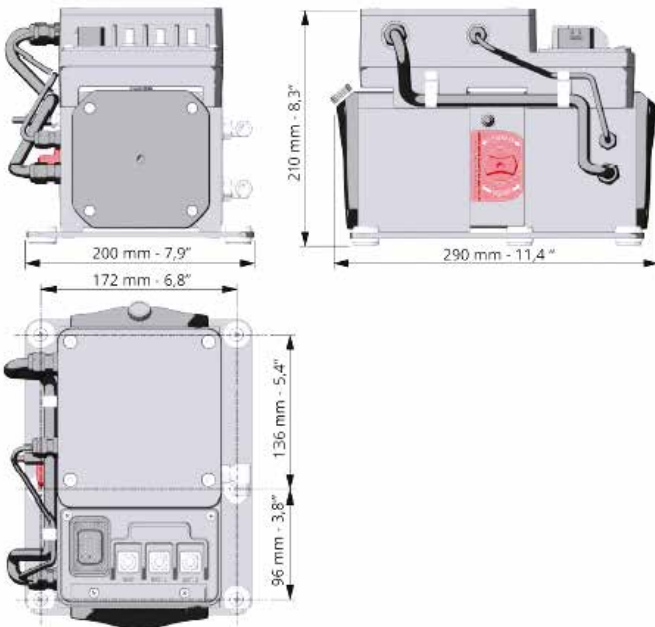

UIP	43541E	High Power Power unit
UIPC	43859N	Compact power unit



# Integra™ Inboard electronic power steering systems

UC120E-I



**new**



UC120E-I

• **UC120E-I:** heavy-duty cylinder with integrated sensor  
Part number - 44034S

Volume	120 cc - 7.5 cu. in
Output force	800 kg - 1764 lbs
Internal diameter	36.5 mm - 1.44"
Stroke	184 mm - 7.24"
Oil	OL460

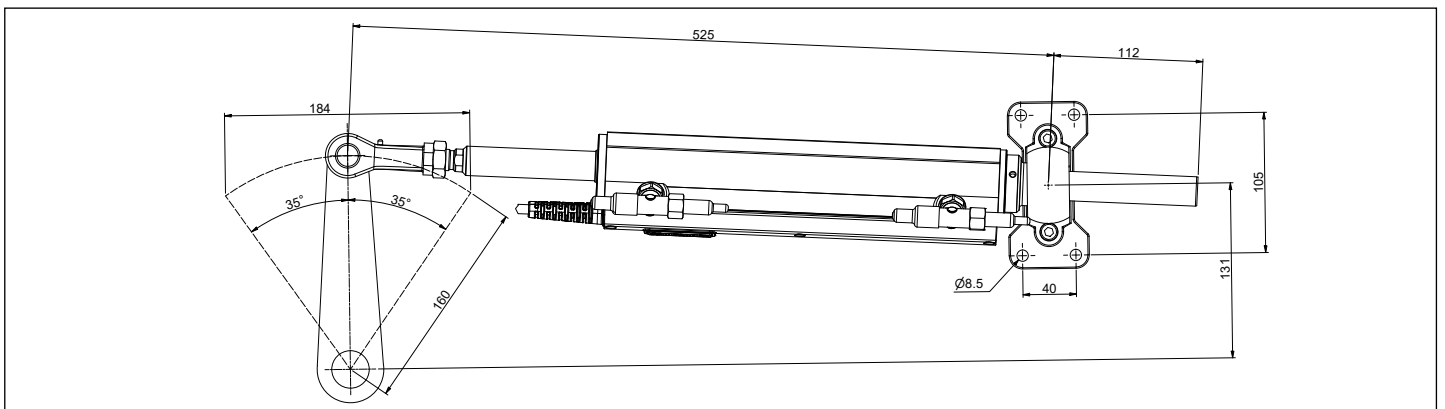

UC120E-I DIMENSIONS

Single engine, single cylinder

## INTEGRA EPS

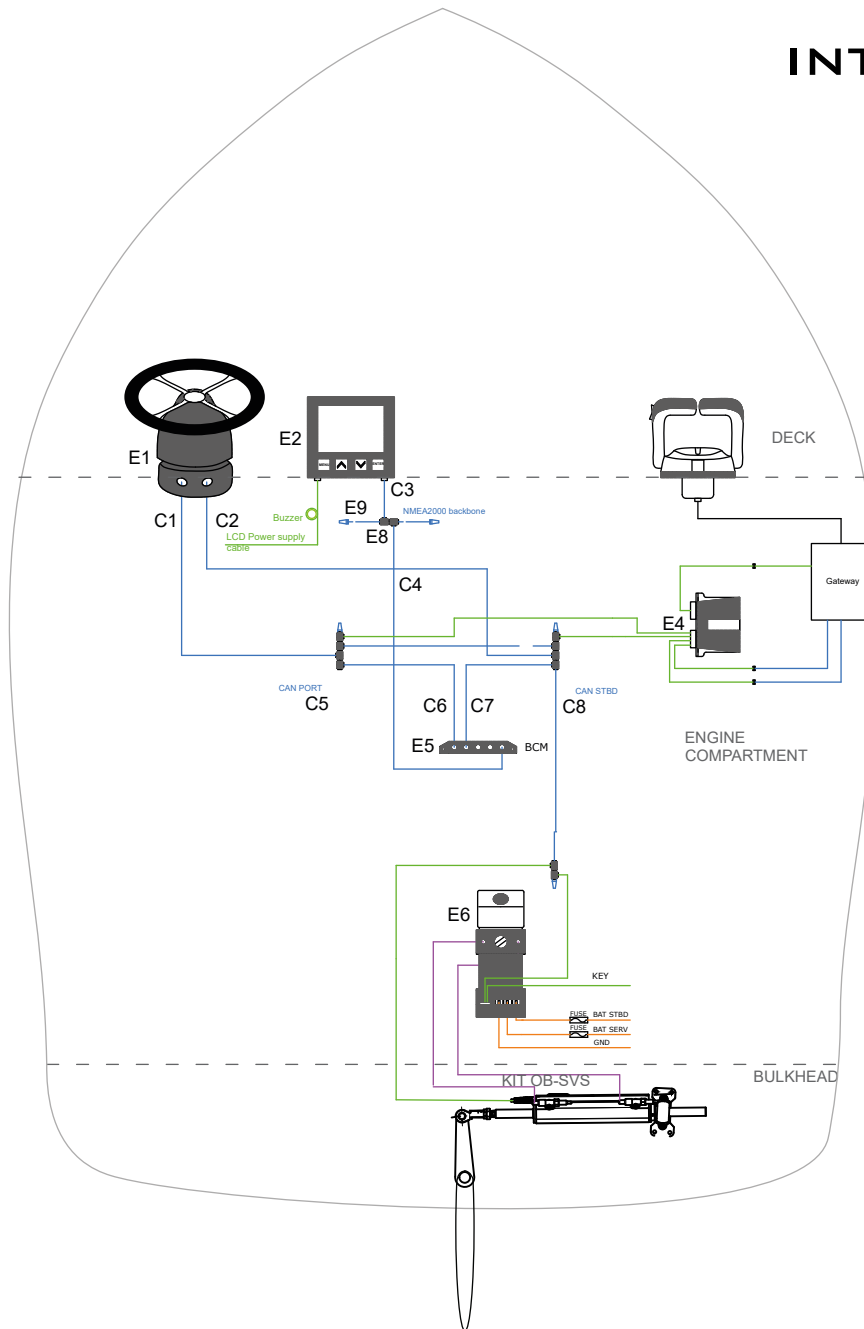

### Main components

Name	Description	Quantity
E1	UIH1 Electronic helm - 43536M	1
E1	X82 Tilt mechanism - 43187N	1
E2	Veratron display - 43539U	1
E3	BCM - Body control module - 43540C	1
E4	UIPC compact power unit - 43859N	1
E5	UC120E-I Cylinder with sensor included - 44034S	1
E6	CAN bus - Tee connection - 43578E	9
E7	CAN bus - Terminator pair - 43576A	3
C1-C8	CAN-bus cables - length on request	8
KIT OB-SVS	Hydraulic hoses kit - length on request	1

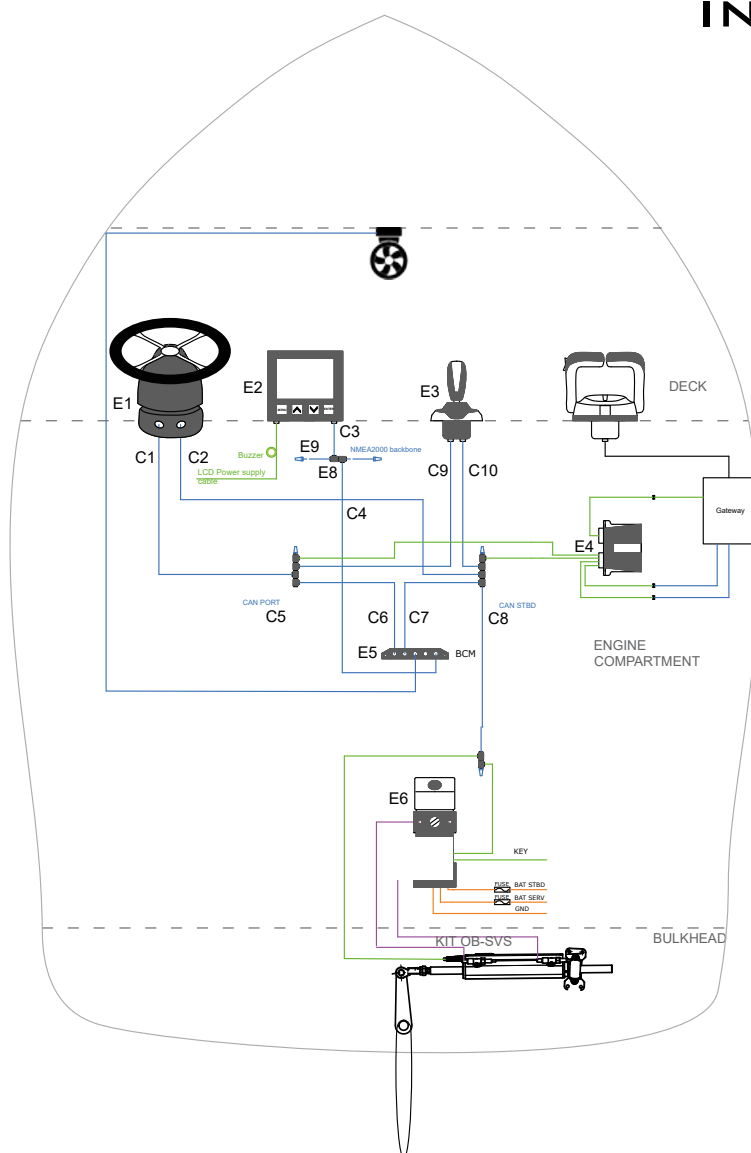

### Main components

Name	Description	Quantity
E1	UIH1 Electronic helm - 43536M	1
E1	X82 Tilt mechanism - 43187N	1
E2	Veratron display - 43539U	1
E3	UJS-B joystick - 44162B	1
E4	Gateway	1
E5	BCM - Body control module - 43540C	1
E6	UIPC compact power unit - 43859N	2
E7	UC120E-I Cylinder with sensor included - 44034S	1
E9	CAN bus - Tee connection - 43578E	12
E10	CAN bus - Terminator pair - 43576A	3



## V99 - Portofino

### Composite steering wheels - hub included



V99 B/B/CH - Ø 350 mm (13.8")



V99 B/CB/CB - Ø 350 mm (13.8")



V99 B/S/S - Ø 350 mm (13.8")



V99 B/CH/CH - Ø 350 mm (13.8")

Model	Portofino
Depth	78 mm (3")
Grip material	Soft touch thermoplastic antishock material
Grip color	Black
Spokes	Black thermoplastic antishock material with inserts
Floating cap	n.a.
Standard 3/4" hub	Included
QDH hub	n.a.
Certifications & standards	CE, UKCA, NMMA; ISO 23411 & ABYC P22

Model	Part No.	Description
V99 B/B/CH	43015G	Thermoplastic antishock material grip and spokes with chrome plated inserts and black cover
V99 B/CB/CB	43405W	Thermoplastic antishock material grip and spokes with carbon inserts and cover
V99 B/S/S	43404U	Thermoplastic antishock material grip and spokes with silver inserts and cover
V99 B/CH/CH	43016J	Thermoplastic antishock material grip and spokes with chrome plated inserts and cover

## V32 - V33 - V45 Composite steering wheels - hub included



V32B - Ø 335 mm (13.2")



V33B - Ø 342 mm (13.4")



V45B - Ø 280 mm (11")



V45W - Ø 280 mm (11")



V45G - Ø 280 mm (11")

Model	V32	V33	V45
Depth	92 mm (3.62")	105 mm (4.1")	82 mm (3.2")
Grip material	Thermoplastic antishock material		
Grip color	Black	Black	Black, white, gray
Spokes	Thermoplastic antishock material		
Floating cap	n.a.		
Standard 3/4" hub	Included		
QDH hub	n.a.		
Certifications & standards	CE, UKCA, NMMA; ISO 23411 & ABYC P22		

Model	Part No.	Description
V32B	35458X	Black thermoplastic antishock material grip and spokes
V33B	35819L	Black thermoplastic antishock material grip and spokes
V45B	37920H	Black thermoplastic antishock material grip and spokes
V45W	38049P	White thermoplastic antishock material grip and spokes
V45G	39291J	Gray thermoplastic antishock material grip and spokes



## V19

### Soft touch grip steering wheels

**new**



V19 B/PB - Ø 350 mm (13.8")



V19 B/MB - Ø 350 mm (13.8")



V19 B/MT - Ø 350 mm (13.8")



V19 B/VE - Ø 350 mm (13.8")

Model	V19
Depth	93 mm (3.66")
Grip material	Plastic
Grip color	Black, white, gray
Spokes	Thermoplastic anti-shock material with inserts
Floating cap	n.a.
Standard 3/4" hub	Included
QDH hub	Available upon request
Certifications & standards	CE, UKCA, NMMA; ISO 23411 & ABYC P22

Model	Part No.	Description
V19 B/PB	44115S	Thermoplastic anti-shock material grip and spokes, polished black spokes inserts and ring
V19 B/MB	44156G	Thermoplastic anti-shock material grip and spokes, spokes and ring inserts painted matt black
V19 B/MT	44157J	Thermoplastic anti-shock material grip and spokes, spokes and ring inserts painted matt titanium
V19 B/VE	44158L	Thermoplastic anti-shock material grip and spokes, spokes and ring inserts painted matt chrome

## V60 - V61 Antigua Composite steering wheels - hub included



V60B - Ø 350 mm (13.8")



V60W - Ø 350 mm (13.8")



V60G - Ø 350 mm (13.8")



V61BR - Ø 350 mm (13.8")

Model	V60 - V61
Depth	85 mm (3.3")
Grip material	Thermoplastic antishock material
Grip color	Black, white, gray, burl wood
Spokes	Thermoplastic antishock material
Floating cap	n.a.
Standard 3/4" hub	Included
QDH hub	n.a.
Certifications & standards	CE, UKCA, NMMA; ISO 23411 & ABYC P22

Model	Part No.	Description
V60B	39189U	Black thermoplastic antishock material grip and spokes
V60W	39190C	White thermoplastic antishock material grip and spokes
V60G	39274J	Gray thermoplastic antishock material grip and spokes
V61BR	39191E	Burl wood thermoplastic antishock material grip and spokes

## Corse Soft touch grip steering wheels - hub included



Corse B/S - Ø 350 mm (13.8")



Corse B/B - Ø 350 mm (13.8")



Corse W/S - Ø 350 mm (13.8")



Corse G/S - Ø 350 mm (13.8")

Model	Corse
Depth	88 mm (3.46")
Grip material	Soft touch
Grip color	Black, white, gray
Spokes	Silver or black anodized aluminum
Floating cap	n.a.
Standard 3/4" hub	Included
QDH hub	Available upon request
Certifications & standards	CE, UKCA, NMMA; ISO 23411 & ABYC P22

Model	Part No.	Description
Corse B/S	383330	Black soft touch grip, silver aluminum spokes
Corse B/B	38332N	Black soft touch grip, black aluminum spokes
Corse W/S	38334P	White soft touch grip, silver aluminum spokes
Corse G/S	38393H	Gray soft touch grip, silver aluminum spokes
RING S	61820L	Silver center ring (optional)

## Vivara - Linosa - Budelli Polyurethane grip steering wheels - hub included



Vivara CH/P - Ø 350 mm (13.8")



Linosa S/S - Ø 350 mm (13.8")



Budelli B/P/CH - Ø 350 mm (13.8")



Budelli CH/S - Ø 350 mm (13.8")

Model	Vivara	Linosa	Budelli
Depth	88 mm (3.46")	91 mm (3.58)	94 mm (3.7)
Grip material	Leather look polyurethane with polished inserts		
Grip color	Black		
Spokes	Polished aluminum	Silver aluminum	Polished or silver aluminum
Floating cap	n.a.	n.a.	n.a.
Standard 3/4" hub	Included		
QDH hub	Available upon request		
Certifications & standards	CE, UKCA, NMMA; ISO 23411 & ABYC P22		

Model	Part No.	Description
Vivara CH/P	64643G	Black polyurethane grip with polished inserts, polished aluminum spokes
Linosa S/S	64295K	Black polyurethane grip with polished inserts, silver aluminum spokes
Budelli B/P/CH	65294N	Black polyurethane grip with polished inserts, silver aluminum spokes
Budelli CH/S	65293L	Black polyurethane grip with polished inserts, polished aluminum spokes



## Nisida - Palmaria - Santorini

### Polyurethane grip steering wheels - hub included



**Nisida B/S - Ø 350 mm (13.8")**



**Nisida B/B - Ø 350 mm (13.8")**



**Palmaria B/B - Ø 350 mm (13.8")**



**Santorini B/S - Ø 350 mm (13.8")**

Model	Nisida	Palmaria	Santorini
Depth	85 mm (3.35")	40 mm (1.57")	85 mm (3.35")
Grip material	Leather look polyurethane		Soft touch
Grip color	Black		
Spokes	Silver or black anodized aluminum	Black anodized aluminum	
Floating cap	n.a.		
Standard 3/4" hub	Included		
QDH hub	Available upon request		
Certifications & standards	CE, UKCA, NMMA; ISO 23411 & ABYC P22		

Model	Part No.	Description
Nisida B/S	61813P	Black polyurethane grip, silver aluminum spokes
Nisida B/B	61812M	Black polyurethane grip, black aluminum spokes
Palmaria B/B	63727H	Black polyurethane grip, black aluminum spokes
Santorini B/S	65995W	Black polyurethane grip with silver painted inserts, aluminum spokes

## Pianosa - Manna

### Polyurethane grip steering wheels - hub included



**Pianosa B/S - Ø 350 mm (13.8")**



**Pianosa B/B - Ø 350 mm (13.8")**



**Pianosa B/SS - Ø 350 mm (13.8")**



**Manna B/B/B - Ø 350 mm (13.8")**

**new**

<b>Model</b>	Pianosa
<b>Depth</b>	88 mm (3.46")
<b>Grip material</b>	Leather look polyurethane
<b>Grip color</b>	Black
<b>Spokes</b>	Stainless steel or silver or black anodized aluminum
<b>Floating cap</b>	n.a.
<b>Standard 3/4" hub</b>	Included
<b>QDH hub</b>	Available upon request
<b>Certifications &amp; standards</b>	CE, UKCA, NMMA; ISO 23411 & ABYC P22

Model	Part No.	Description
<b>Pianosa B/SS</b>	22961K	Black polyurethane grip, SS spokes, polished ring
<b>Pianosa B/B</b>	22960H	Black polyurethane grip, black aluminum spokes, black painted ring
<b>Pianosa B/S</b>	22322Y	Black polyurethane grip, silver aluminum spokes, polished ring
<b>Manna B/B/B</b>	25896T	Black polyurethane grip with silver painted inserts, aluminum spokes
<b>RING PS</b>	23029F	Silver center ring (optional)
<b>RING PB</b>	23030P	Black center ring (optional)



## Capraia - Tavolara - Domino

Polyurethane grip steering wheels - hub included



Capraia B/S - Ø 350 mm (13.8")



Tavolara B/S/CH - Ø 350 mm (13.8")



Domino B/B - Ø 350 mm (13.8")



Domino B/S - Ø 350 mm (13.8")

Model	Capraia	Domino
Depth	84 mm (3.3")	88 mm (3.46")
Grip material	Leather look polyurethane	
Grip color	Black	Black
Spokes	Silver or black anodized aluminum	Silver or black anodized aluminum
Floating cap	n.a.	n.a.
Standard 3/4" hub	Included	
QDH hub	Available upon request	
Certifications & standards	CE, UKCA, NMMA; ISO 23411 & ABYC P22	

Model	Part No.	Description
Capraia B/S	22958X	Black polyurethane grip, silver aluminum spokes
Tavolara B/S/CH	23916K	Black polyurethane grip, black aluminum spokes, chrome plated cover
Domino B/B/CH	23897J	Black polyurethane grip, black aluminum spokes, chrome plated cover
Domino B/B	23896G	Black polyurethane grip, black aluminum spokes and ring
Domino B/S	23895E	Black polyurethane grip, silver aluminum spokes and ring

## Ustica - Levanzo

### Polyurethane grip steering wheels - hub included



**Ustica B/S/B - Ø 330 mm (13")**



**Ustica B/B/B - Ø 330 mm (13")**



**Levanzo B/S/CH - Ø 330 mm (13")**



**KNOB UST**

Model	Ustica	Levanzo
Depth	90 mm (3.54")	90 mm (3.54")
Grip material	Leather look PUR	Leather look PUR with chrome plated inserts
Grip color		Black
Spokes	Silver or black anodized aluminum	Silver anodized aluminum
Floating cap	n.a.	n.a.
Standard 3/4" hub		Included
QDH hub	Available upon request	
Certifications & standards	CE, UKCA, NMMA; ISO 23411 & ABYC P22	

Model	Part No.	Description
Ustica B/S/B	20926X	Black polyurethane grip, silver aluminum spokes, black painted cover
Ustica B/B/B	21622F	Black polyurethane grip, black aluminum spokes, black painted cover
Levanzo B/S/CH	20927Z	Black PUR grip with chrome plated inserts, silver aluminum spokes, chrome plated cover
KNOB UST	21721H	Knob for Ustica and Levanzo steering wheels

## Giannutri - Pantelleria

Polyurethane grip steering wheels - hub included



Giannutri PU B/SS - Ø 280 mm (11")



Giannutri PU W/SS - Ø 280 mm (11")



Pantelleria B/S - Ø 320 mm (12.6")



Pantelleria B/B - Ø 320 mm (12.6")

Model	Pantelleria	Giannutri
Depth	90 mm (3.58")	69 mm (2.7")
Grip material	Leather look polyurethane	
Grip color	Black	Black or white
Spokes	Silver or black anodized aluminum	Polished stainless steel
Floating cap	n.a.	
Standard 3/4" hub	Included	
QDH hub	Available upon request	
Certifications & standards	CE, UKCA, NMMA; ISO 23411 & ABYC P22	

Model	Part No.	Description
Pantelleria B/S	22232X	Black polyurethane grip, silver aluminum spokes
Pantelleria B/B	25102Z	Black polyurethane grip, black aluminum spokes
Giannutri PU B/SS	23477P	Black polyurethane grip, SS spokes, polished ring
Giannutri PU W/SS	23476H	White polyurethane grip, SS spokes, polished ring

**Gallinara**  
Vinyl and polyurethane grip steering wheels - hub included

new



**Gallinara PU B/SS - Ø 320 mm (12.6")**



**Gallinara V B/SS - Ø 320 mm (12.6")**



**Gallinara V W/SS - Ø 320 mm (12.6")**

<b>Model</b>	<b>Gallinara</b>
<b>Depth</b>	88 mm (3.46")
<b>Grip material</b>	Polyurethane and vinyl
<b>Grip color</b>	Black or White
<b>Spokes</b>	Stainless Steel
<b>Floating cap</b>	n.a.
<b>Standard 3/4" hub</b>	<b>Included</b>
<b>QDH hub</b>	Available upon request
<b>Certifications &amp; standards</b>	CE, UKCA, NMMA; ISO 23411 & ABYC P22

<b>Model</b>	<b>Part No.</b>	<b>Description</b>
<b>Gallinara PU B/SS</b>	25881D	Black polyurethane grip, SS spokes, black cover
<b>Gallinara V B/SS</b>	25899Z	Black vinyl polyurethane grip, SS spokes, black cover
<b>Gallinara V W/SS</b>	25922R	White vinyl grip, SS spokes, white cover

## Montecristo

### Polyurethane grip steering wheels - hub included



Montecristo B/SS/CH - Ø 350 mm (13.8")



Montecristo B/S/S - Ø 350 mm (13.8")



Montecristo B/B/CH - Ø 350 mm (13.8")



Montecristo B/B/P/CH - Ø 350 mm (13.8")

Model	Montecristo
Depth	SS spokes 94 mm (3.7") aluminum spokes 98 mm (3.86")
Grip material	Leather look polyurethane
Grip color	Black
Spokes	Polished 304 stainless steel or silver or black anodized aluminum
Center cap	Chrome plated, or silver, or black painted
Floating cap	Available upon request
Standard 3/4" hub	Included
QDH hub	Available upon request
Certifications & standards	CE, UKCA, NMMA; ISO 23411 & ABYC P22

Model	Part No.	Description
Montecristo B/SS/CH	20470D	Black polyurethane grip, SS spokes, black cover
Montecristo B/S/S	20350T	Black polyurethane grip, silver aluminum spokes, black cover
Montecristo B/B/CH	20351V	Black polyurethane grip, black aluminum spokes, black cover
Montecristo B/B/P/CH	23590F	Black polyurethane grip, black aluminum spokes with chrome plated inserts



**Vinyl and polyurethane grip steering wheels - hub included**



**Asinara V B/SS/L - Ø 350 mm (13.8")**



**Asinara PU B/SS/B - Ø 350 mm (13.8")**



**Asinara PU B/S/B - Ø 350 mm (13.8")**



**Asinara PU B/B/B - Ø 350 mm (13.8")**

<b>Model</b>	<b>Asinara</b>
<b>Depth</b>	SS spokes 92 mm (3.62") aluminum spokes 95 mm (3.74")
<b>Grip material</b>	Vinyl or leather look polyurethane
<b>Grip color</b>	Black
<b>Spokes</b>	Polished 304 stainless steel or silver or black anodized aluminum
<b>Center cap</b>	Black leather with embossed logo
<b>Floating cap</b>	Available upon request
<b>Standard 3/4" hub</b>	Included
<b>QDH hub</b>	Available upon request
<b>Certifications &amp; standards</b>	CE, UKCA, NMMA; ISO 23411 & ABYC P22

<b>Model</b>	<b>Part No.</b>	<b>Description</b>
<b>Asinara V B/SS/L</b>	24732E	Black vinyl grip, SS spokes, SS cover
<b>Asinara PU B/SS/B</b>	24729S	Black polyurethane grip, SS spokes, SS cover
<b>Asinara PU B/S/B</b>	24730A	Black polyurethane grip, silver aluminum spokes, SS cover
<b>Asinara PU B/B/B</b>	24731C	Black polyurethane grip, black aluminum spokes, SS cover



# Giglio

## Polyurethane grip steering wheels

**new**

CHRISTIANGRANDE  
DesignWorks



Giglio B/S/PB - Ø 350 mm (13.8")



Giglio B/SS/PB - Ø 350 mm (13.8")



Giglio B/B/VE - Ø 350 mm (13.8")



Giglio B/B/PB - Ø 350 mm (13.8")

CHRISTIANGRANDE  
DesignWorks

Model	Giglio
Depth	88 mm (3.46")
Grip material	Leather look polyurethane
Grip color	Black
Spokes	Chrome or black aluminum or stainless steel
Floating cap	n.a.
Standard 3/4" hub	Included
QDH hub	Available upon request
Certifications & standards	CE, UKCA, NMMA; ISO 23411 & ABYC P22

Model	Part No.	Description
Giglio B/S/PB	25897VU	Black PU grip with polished black inserts, silver anodized aluminum spokes, black and polished black painted cover
Giglio B/SS/PB	25898XU	Black PU grip with polished black inserts, stainless steel spokes, black and polished black painted cover
Giglio B/B/VE	25911KU	Black PU grip with silver painted inserts, black anodized aluminum spokes, silver painted cover
Giglio B/B/PB	25943Z	Black PU grip with black painted inserts, black anodized aluminum spokes, black painted cover



Different coloured inserts available

V15 - Polyurethane grip steering wheels - hub included  
 Razzoli - Mahogany grip steering wheels - hub included



V15 B/SS/F - Ø 350 mm (13.8")

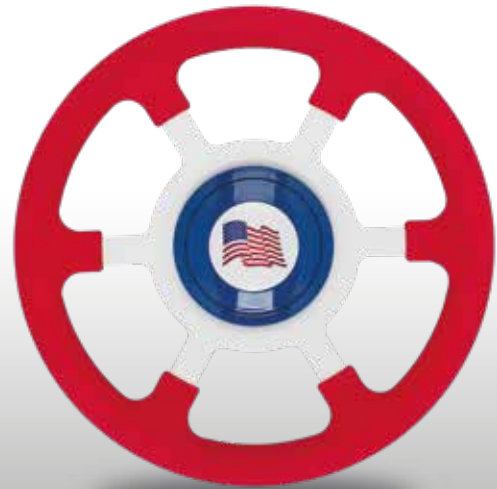

V15 R/W/F - Ø 350 mm (13.8")



Razzoli M/SS/BR - Ø 350 mm (13.8")



Razzoli M/SS/SS - Ø 350 mm (13.8")

Model	V15	RAZZOLI
Depth	94 mm (3.7")	85,5 mm (3.37")
Grip material	Polyurethane	Mahogany wood
Grip color	Black, red	Mahogany
Spokes	Stainless steel or white painted aluminum	Stainless steel
Floating cap	available upon request	
Standard 3/4" hub	Included	
QDH hub	n.a.	Available upon request
Certifications & standards	CE, UKCA, NMMA; ISO 23411 & ABYC P22	

Model	Part No.	Description
V15 B/SS/F	22325E	Black polyurethane grip, SS spokes
V15 R/W/F	22323A	Red polyurethane grip, white painted aluminum spokes
Razzoli M/SS/BR	23612N	Mahogany grip, stainless steel spokes, burl cover
Razzoli M/SS/SS	24703X	Mahogany grip, stainless steel spokes, stainless steel cover

**V75**  
Polyurethane grip steering wheels

**new**



V75 B/VE - Ø 350 mm (13.8")



V75 B/PB - Ø 350 mm (13.8")



V75 W/VE - Ø 350 mm (13.8")

Model	V75
Depth	98 mm (3.85")
Grip material	Leather look polyurethane
Grip color	Black or White
Spokes	Silver painted or black
Floating cap	n.a.
Standard 3/4" hub	Included
QDH hub	n.a.
Certifications & standards	CE, UKCA, NMMA; ISO 23411 & ABYC P22

Model	Part No.	Description
V75 B/VE	25917Y	Black PU grip, silver painted spokes, black cover
V75 B/PB	25918B	Black PU grip, polished black spokes, black cover
V75 W/VE	22322Y	White PU grip, silver painted spokes, white cover

Traditional style equidistant spoke steering wheels - hub included



V70B - Ø 350 mm (13.8")



V70W - Ø 350 mm (13.8")



V70G - Ø 350 mm (13.8")

Model	V70
Depth	93 mm (3.66")
Grip material	Polyurethane
Grip color	Black, white, gray
Spokes	Stainless steel
Floating cap	n.a.
Standard 3/4" hub	Included
QDH hub	n.a.
Certifications & standards	CE, UKCA, NMMA; ISO 23411 & ABYC P22

Model	Part No.	Description
V70B	39442D	Black polyurethane grip, SS spokes
V70W	39929J	White polyurethane grip, SS spokes
V70G	39441B	Gray polyurethane grip, SS spokes

## V56

Traditional style equidistant spoke steering wheels - hub included



V56 B/CH - Ø 350 mm (13.8")



V56 B/CH - Ø 350 mm (13.8")



V56 W/CH - Ø 350 mm (13.8")



V56 G/CH - Ø 350 mm (13.8")

Model	V56
Depth	95 mm (3.74")
Grip material	Polyurethane
Grip color	Black, white, gray
Spokes	Polyurethane with inserts
Floating cap	n.a.
Standard 3/4" hub	Included
QDH hub	n.a.
Certifications & standards	CE, UKCA, NMMA; ISO 23411 & ABYC P22

Model	Part No.	Description
V56 B/CH	21351A	Black polyurethane grip and spokes with chrome plated inserts
V56 W/CH	21406Z	White polyurethane grip and spokes with chrome plated inserts
V56 G/CH	21407B	Gray polyurethane grip and spokes with chrome plated inserts
V56 B/R	21524F	Black polyurethane grip and spokes with red painted inserts
V56 B/KG	21525H	Black polyurethane grip and spokes with green painted inserts
V56 B/O	21526K	Black polyurethane grip and spokes with orange painted inserts



Traditional style equidistant spoke steering wheels - hub included



V56 B/R - Ø 350 mm (13.8")



V56 B/KG - Ø 350 mm (13.8")



V56 W/W - Ø 350 mm (13.8")



KV56-O



KV56-BP



KV56-R



KV56-KG



KV56-WP

V56 color inserts - customize V56 steering wheel



KNOB V56

Model	Part No.	Description
KV56-O	21412U	Orange kit inserts
KV56-BP	21414Y	Black polished kit inserts
KV56-R	21411S	Red kit inserts
KV56-KG	21413W	Green kit inserts
KV56-WP	21415A	White polished kit inserts
KNOB V56	23600F	Knob for V56 steering wheel



## V24

### Polyurethane grip equidistant spoke steering wheels - hub included



V24B - Ø 350 mm (13.8")



V24W - Ø 350 mm (13.8")



V24G - Ø 350 mm (13.8")



V24 COMMANDO - Ø 350 mm (13.8")

Model	V24
Depth	75 mm (2.95")
Grip material	Polyurethane
Grip color	Black, white, gray
Spokes	Stainless steel
Floating cap	n.a.
Standard 3/4" hub	Included
QDH hub	n.a.
Certifications & standards	CE, UKCA, NMMA; ISO 23411 & ABYC P22

Model	Part No.	Description
V24B	42345Z	Black polyurethane grip, SS spokes
V24W	42347D	White polyurethane grip, SS spokes
V24G	42346B	Gray polyurethane grip, SS spokes
V24 COMMANDO	42370Y	Black polyurethane grip, black painted SS spokes

Polyurethane, mahogany or SS grip equidistant spoke steering wheels - hub included



V25B - Ø 350 mm (13.8")



V25W - Ø 350 mm (13.8")



V25G - Ø 350 mm (13.8")



V25SS - Ø 350 mm (13.8")



V25M - Ø 350 mm (13.8")

Model	V25
Depth	57 mm (2.24")
Grip material	Polyurethane, stainless steel, mahogany
Grip color	Black, white, gray, stainless steel, teak
Spokes	Stainless steel
Floating cap	n.a.
Standard 3/4" hub	Included
QDH hub	n.a.
Certifications & standards	CE, UKCA, NMMA; ISO 23411 & ABYC P22

Model	Part No.	Description
V25B	40640R	Black polyurethane grip, SS spokes
V25W	40642W	White polyurethane grip, SS spokes
V25G	40641T	Gray polyurethane grip, SS spokes
V25SS	40643X	Stainless steel grip and spokes
V25M	40644Z	Mahogany grip, SS spokes

## V10

Polyurethane, teak or SS grip equidistant spoke steering wheels - hub included



V10B - Ø 350 mm (13.8")



V10W - Ø 350 mm (13.8")



V10G - Ø 350 mm (13.8")



V10SS - Ø 350 mm (13.8")



V10TK - Ø 350 mm (13.8")

Model	V10
Depth	Ø 350 mm: 67 mm (2.64") / Ø 400 mm: 73 mm (2.87")
Grip material	Polyurethane, stainless steel, teak
Grip color	Black, white, gray, stainless steel, teak
Spokes	Stainless steel
Floating cap	n.a.
Standard 3/4" hub	Included
QDH hub	n.a.
Certifications & standards	CE, UKCA, NMMA; ISO 23411 & ABYC P22

Model	Part No.	Description
V10B	41693U	Black polyurethane grip, SS spokes
V10W	41694W	White polyurethane grip, SS spokes
V10G	41695Y	Gray polyurethane grip, SS spokes
V10SS	41699G	Stainless steel grip and spokes
V10TK 35	41697C	Teak grip, SS spokes

Polyurethane or SS grip equidistant spoke steering wheels - hub included



V01B - Ø 350 mm (13.8")



V01W - Ø 350 mm (13.8")



V01G - Ø 350 mm (13.8")



V01SS - Ø 350 mm (13.8")

Model	V01
Depth	67 mm (2.64")
Grip material	Polyurethane, stainless steel
Grip color	Black, white, gray, stainless steel
Spokes	Stainless steel
Floating cap	n.a.
Standard 3/4" hub	Included
QDH hub	n.a.
Certifications & standards	CE, UKCA, NMMA; ISO 23411 & ABYC P22

Model	Part No.	Description
V01B	41687Z	Black polyurethane grip, SS spokes
V01W	41688B	White polyurethane grip, SS spokes
V01G	41689D	Gray polyurethane grip, SS spokes
V01SS	41692S	Stainless steel grip and spokes

## V57 - V31

Polyurethane grip equidistant spoke steering wheels - hub included



V57B - Ø 350 mm (13.8")



V57W - Ø 350 mm (13.8")



V57G - Ø 350 mm (13.8")



V31B - Ø 320 mm (12.6")

Model	V57	V31
Depth	76 mm (2.99")	75 mm (2.95)
Grip material	Polyurethane	
Grip color	Black, white, gray	Black
Spokes	Stainless steel	
Floating cap	n.a.	n.a.
Standard 3/4" hub	Included	
QDH hub	n.a.	n.a.
Certifications & standards	CE, UKCA, NMMA; ISO 23411 & ABYC P22	

Model	Part No.	Description
V57B	38155O	Black polyurethane grip, SS spokes
V57W	38157Q	White polyurethane grip, SS spokes
V57G	38156P	Gray polyurethane grip, SS spokes
V31B	43006F	Black polyurethane grip, SS spokes



new



V76 B/VE - Ø 320 mm (12.6")



V76 B/PB - Ø 320 mm (12.6")



V76 W/CH - Ø 320 mm (12.6")

Model	V76
Depth	92 mm (3.62")
Grip material	Leather look polyurethane
Grip color	Black or White
Spokes	Silver painted or black
Floating cap	n.a.
Standard 3/4" hub	Included
QDH hub	n.a.
Certifications & standards	CE, UKCA, NMMA; ISO 23411 & ABYC P22

Model	Part No.	Description
V76 B/VE	25915U	Black PU grip, silver painted spokes, black cover
V76 B/PB	25916W	Black PU grip, polished black spokes, black cover
V76 W/VE	22322Y	White PU grip, silver painted spokes, white cover



## V52 - V58 - V74 - V77

Traditional style equidistant spoke steering wheels - hub included



V52B - Ø 320 mm (12.6")



V52W - Ø 320 mm (12.6")



V52G - Ø 320 mm (12.6")



V58G - Ø 400 mm (15.7")



V74/40 - Ø 400 mm (15.7")



V77/40 - Ø 400 mm (15.7")

Model	V52	V58	V74	V77
Depth	73 mm (2.87")	78 mm (3.07")	63 mm (2.48")	63 mm (2.48")
Grip material	Polyurethane		Mahogany	Natural teak
Grip color	Black, white, gray	Gray	Mahogany	Natural teak
Spokes	Stainless steel			
Floating cap	n.a.			
Standard 3/4" hub	Included			
QDH hub	n.a.			
Certifications & standards	CE, UKCA, NMMA; ISO 23411 & ABYC P22			

Model	Part No.	Description
V52B	40631P	Black polyurethane grip, SS spokes
V52W	40633U	White polyurethane grip, SS spokes
V52G	40632S	Gray polyurethane grip, SS spokes
V58G	38650F	Gray polyurethane grip, SS spokes
V74/40	41115A	Mahogany grip, SS spokes
V77/40	41152G	Natural teak grip, SS spokes



VERO VOLANTE ITALIANO



VERO VOLANTE ITALIANO

## Boccanegra Vero Volante Italiano



VERO VOLANTE ITALIANO



  
CHRISTIANGRANDE  
DesignWorks

Boccanegra L B/L

3-spoke steering wheel.  
Polished 316L stainless steel spokes.  
Hand-stitching leather grip.  
Leather wrapped, chrome plated or painted cover.  
Leather wrapped or painted center cap.

Hub included - standard 3/4" taper

Ø = 350 mm (13.8")

Depth = 89 mm (3.5")



**Boccanegra L B/L**



**Boccanegra L W/L**



**Boccanegra L B/CH**



**Boccanegra V B/P**

<b>Diameter</b>	350 mm (13.8")
<b>Grip material</b>	Leather and Vynil
<b>Grip color</b>	Black, white
<b>Spokes</b>	Polished 316L stainless steel
<b>Center cap</b>	Leather or painted
<b>Floating cap</b>	n.a.
<b>Standard 3/4" hub</b>	Included
<b>QDH hub</b>	n.a.
<b>Certifications &amp; standards</b>	CE, UKCA, NMMA; ISO 23411 & ABYC P22

<b>Model</b>	<b>Part No.</b>	<b>Description</b>
<b>Boccanegra L B/L</b>	67460P	Black leather grip, stainless steel spokes, black leather cover
<b>Boccanegra L W/L</b>	67295B	White leather grip, stainless steel spokes, white leather cover
<b>Boccanegra L B/CH</b>	20944Z	Black leather grip, stainless steel spokes, chrome plated cover
<b>Boccanegra V B/P</b>	68714A	Black vynil grip, stainless steel spokes, black painted cover



Oderico  
Vero Volante Italiano



VERO VOLANTE ITALIANO



Oderico L B/SS/CH

3-Spoke steering wheel

Oderico spokes are made of 316L stainless steel and have a **double treatment**: polished on the left side of the spoke and black sandblasted on the right side.

Grip is available in black hand-stitching leather or vinyl

Hub included - standard 3/4" taper.

Ø = 350 mm (13.8")

Depth = 75 mm (2.95")



Oderico L B/SS/CH



Oderico V B/SS/CH



<b>Diameter</b>	350 mm (13.8")
<b>Grip material</b>	Leather or vinyl
<b>Grip color</b>	Black
<b>Spokes</b>	Polished and black sandblasted 316L SS
<b>Center cap</b>	Chrome plated
<b>Floating cap</b>	Available upon request
<b>Standard 3/4" hub</b>	Included
<b>QDH hub</b>	n.a.
<b>Certifications &amp; standards</b>	CE, UKCA, NMMA; ISO 23411 & ABYC P22

Model	Part No.	Description
Oderico L B/SS/CH	69570H	Black leather grip, stainless steel spokes, black painted cover
Oderico V B/SS/CH	69563L	Black vinyl grip, stainless steel spokes, black painted cover



Vendramin  
Vero Volante Italiano

new



VERO VOLANTE ITALIANO



Vendramin L B/SS/RG

3 spokes 316L polished stainless steel wheel with metachrilate inserts.

Grip available in:

- Hand-stitched leather
- Hand-stitched vinyl
- Leather look polyurethane

Stainless steel cover, leather or vinyl or pad-printed center cap

Hub included - standard 3/4" taper

Ø = 350 mm (13.8")

Depth = 97 mm (3.8")



Vendramin L B/SS/RG



Vendramin V B/SS/B



Vendramin PU B/SS/RG



Vendramin PU B/SS/B

Diameter	350 mm (13.8")
Grip material	Leather or vinyl or leather look polyurethane
Grip color	Black
Spokes	Polished 316L SS and inserts
Center cap	Leather or vinyl or pad-printed
Floating cap	Available upon request
Standard 3/4" hub	Included
QDH hub	n.a.
Certifications & standards	CE, UKCA, NMMA; ISO 23411 & ABYC P22

Model	Part No.	Description
Vendramin L B/SS/RG	25894N	Black leather grip, stainless steel spokes, stainless steel cover, rose gold painted inserts
Vendramin V B/SS/B	25913P	Black vinyl grip, stainless steel spokes, stainless steel cover, polished black inserts
Vendramin PU B/SS/RG	25893L	Black PU grip, stainless steel spokes, stainless steel cover, rose gold painted inserts
Vendramin PU B/SS/B	25912M	Black PU grip, stainless steel spokes, stainless steel cover, polished black inserts

## Soranzo Vero Volante Italiano



VERO VOLANTE ITALIANO



  
CHRISTIANGRANDE  
DesignWorks

Soranzo L B/L/L

3-spoke steering wheel.  
Polished 316L stainless steel spokes.  
Grip is available in hand-stitching leather or vinyl.  
Leather wrapped or painted cover, leather or vinyl center cap.

Hub included - standard 3/4" taper

Ø = 350 mm (13.8")

Depth = 97 mm (3.8")



**Soranzo L B/L/L**



**Soranzo L L/L/L**



**Soranzo L BL/L/L**



**Soranzo V B/B/L**

<b>Diameter</b>	350 mm (13.8")
<b>Grip material</b>	Leather or vinyl
<b>Grip color</b>	Black, tan leather, blue
<b>Spokes</b>	Polished 316L stainless steel
<b>Center cap</b>	Leather or vinyl
<b>Floating cap</b>	Available upon request
<b>Standard 3/4" hub</b>	Included
<b>QDH hub</b>	n.a.
<b>Certifications &amp; standards</b>	CE, UKCA, NMMA; ISO 23411 & ABYC P22

<b>Model</b>	<b>Part No.</b>	<b>Description</b>
<b>Soranzo L B/L/L</b>	24725H	Black leather grip, gray stitches, SS spokes, black leather cover
<b>Soranzo L L/L/L</b>	24727M	Tan leather grip, cream stitches, SS spokes, tan leather painted cover
<b>Soranzo L BL/L/L</b>	24726K	Blue leather grip, light blue stitches, SS spokes, blue leather cover
<b>Soranzo V B/B/L</b>	24728P	Black vinyl grip, gray stitches, SS spokes, black painted cover

new



VERO VOLANTE ITALIANO



Barbarigo L B/SS/B

3-spoke steering wheel.  
Polished 316L stainless steel spokes.  
Grip is available in hand-stitching leather or vinyl.  
Polished 316L stainless steel cover, leather or vinyl center cap.

Hub included - standard 3/4" taper

Ø = 350 mm (13.8")

Depth = 97 mm (3.8")





**Barbarigo L B/SS/B**



**Barbarigo V B/SS/B**



**Barbarigo V C/SS/C**

<b>Diameter</b>	350 mm (13.8")
<b>Grip material</b>	Leather or vinyl
<b>Grip color</b>	Black or cream
<b>Spokes</b>	Polished 316L stainless steel
<b>Center cap</b>	Leather or vinyl
<b>Floating cap</b>	Available upon request
<b>Standard 3/4" hub</b>	Included
<b>QDH hub</b>	n.a.
<b>Certifications &amp; standards</b>	CE, UKCA, NMMA; ISO 23411 & ABYC P22

<b>Model</b>	<b>Part No.</b>	<b>Description</b>
<b>Barbarigo L B/SS/B</b>	25895R	Black leather grip, SS spokes, SS cover
<b>Barbarigo V B/SS/B</b>	25932U	Black vinyl grip, SS spokes, SS cover
<b>Barbarigo V C/SS/C</b>	24726K	Cream vinyl grip, SS spokes, SS cover



## Fregoso Vero Volante Italiano



VERO VOLANTE ITALIANO



  
CHRISTIANGRANDE  
DesignWorks

Fregoso LL AW/A/A

3-spoke steering wheel.  
Polished 304 stainless steel spokes.  
Grip is available in leather or vinyl in two colors.  
Leather wrapped or painted cover, vinyl or painted center cap.

Hub included - standard 3/4" taper

Ø = 350 mm (13.8")

Depth = 81 mm (3.2")

new



Fregoso LV BC/B/C



Fregoso LL BG/B/G



Fregoso LL AW/A/A

Diameter	350 mm (13.8")
Grip material	Leather, vinyl
Grip color	Black and sand, black and gray, reddish purple and white
Spokes	Polished 304 stainless steel
Center cap	Sand color vinyl or reddish purple painted or gray leather
Floating cap	n.a.
Standard 3/4" hub	Included
QDH hub	Available upon request*
Certifications & standards	CE, UKCA, NMMA; ISO 23411 & ABYC P22

Model	Part No.	Description
Fregoso LV BC/B/C	24739V	Black leather external grip, sand color vinyl internal grip, SS spokes, black painted cover
Fregoso LL BG/B/G	25929F	Black leather external grip, gray leather internal grip, stainless steel spokes, black-colored painted cover
Fregoso LL AW/A/A	24741F	Amaranth color leather external grip, white leather internal grip, SS spokes, amaranth painted cover

\* To be specified when ordering the wheel

**Guarco**  
Vero Volante Italiano



VERO VOLANTE ITALIANO



**Guarco L B/SS/CH**

3-spoke steering wheel.  
Polished 316L stainless steel spokes.  
Hand-stitching leather grip, chrome plated or matt black painted cover.

Hub included - standard 3/4" taper

**Ø = 350 mm (13.8")**

**Depth = 96 mm (3.8")**



**Guarco L B/SS/CH**



**Guarco L B/SS/B**



**Guarco L B/SS/B**

<b>Diameter</b>	350 mm (13.8")
<b>Grip material</b>	Leather
<b>Grip color</b>	Black
<b>Spokes</b>	Polished 316L stainless steel
<b>Center cap</b>	Black polished with pad printed logo
<b>Floating cap</b>	Available upon request.
<b>Standard 3/4" hub</b>	Included
<b>QDH hub</b>	n.a.
<b>Certifications &amp; standards</b>	CE, UKCA, NMMA; ISO 23411 & ABYC P22

<b>Model</b>	<b>Part No.</b>	<b>Description</b>
<b>Guarco L B/SS/CH</b>	24737R	Black leather grip, gray stitches, SS spokes, chrome plated cover
<b>Guarco L B/SS/B</b>	24736N	Black leather grip, black stitches, SS spokes, matt black painted cover



## Spinola Vero Volante Italiano



VERO VOLANTE ITALIANO



Spinola L B/P  
Spinola V B/P

3-spoke steering wheel.  
316L stainless steel, polished or brushed spokes.

Hand-stitching leather or vinyl grip.  
Stainless steel cover, leather or vinyl center cap.

Hub included - standard 3/4" taper

Ø = 350 mm (13.8")

Depth = 82 mm (3.22")



**Spinola L B/P**



**Spinola V B/P**



**Spinola L B/BRU**



**Spinola V B/BRU**

<b>Diameter</b>	350 mm (13.8")
<b>Grip material</b>	Leather or vinyl
<b>Grip color</b>	Black
<b>Spokes</b>	Polished or brushed 316L stainless steel
<b>Center cap</b>	Leather or vinyl
<b>Floating cap</b>	Available upon request
<b>Standard 3/4" hub</b>	Included
<b>QDH hub</b>	n.a.
<b>Certifications &amp; standards</b>	CE, UKCA, NMMA; ISO 23411 & ABYC P22

<b>Model</b>	<b>Part No.</b>	<b>Description</b>
<b>Spinola L B/P</b>	23902Y	Black leather grip, polished SS spokes, SS cover
<b>Spinola V B/P</b>	23901W	Black vinyl grip, polished SS spokes, SS cover
<b>Spinola L B/BRU</b>	23900U	Black leather grip, brushed SS spokes, SS cover
<b>Spinola V B/BRU</b>	23899N	Black vinyl grip, brushed SS spokes, SS cover



## Tron Vero Volante Italiano



VERO VOLANTE ITALIANO



Tron L B/SS/PU  
Tron V B/SS/PU  
Tron PU B/SS/PU

3-spoke steering wheel.  
Polished 316L stainless steel spokes.  
Hand-stitching leather or vinyl or leather look polyurethane grip.  
Black polyurethane cover, chrome plated center cap.

Hub included - standard 3/4" taper

Ø = 350 mm (13.8")

Depth = 95 mm (3.74")



**Tron L B/SS/PU**



**Tron V B/SS/PU**



**Tron PU B/SS/PU**

<b>Diameter</b>	350 mm (13.8")
<b>Grip material</b>	Leather or vinyl or leather look polyurethane
<b>Grip color</b>	Black
<b>Spokes</b>	Polished 316L stainless steel
<b>Center cap</b>	Chrome plated
<b>Floating cap</b>	Available upon request
<b>Standard 3/4" hub</b>	Included
<b>QDH hub</b>	n.a.
<b>Certifications &amp; standards</b>	CE, UKCA, NMMA; ISO 23411 & ABYC P22

<b>Model</b>	<b>Part No.</b>	<b>Description</b>
<b>Tron L B/SS/PU</b>	22125V	Black leather grip, SS spokes, black polyurethane cover
<b>Tron V B/SS/PU</b>	22321W	Black vinyl grip, SS spokes, black polyurethane cover
<b>Tron PU B/SS/PU</b>	22124U	Black polyurethane grip, SS spokes, black polyurethane cover

## Dolphin Vero Volante Italiano



VERO VOLANTE ITALIANO



Dolphin L B/B/Pw

316L stainless steel 3-spoke steering wheel with inserts.

Spokes available in:

- Matt black painted stainless steel and polished black inserts
- Matt black painted stainless steel and pewter effect inserts
- Polished stainless steel and polished black inserts

Hand-stitched leather or vinyl grip.

Black painted cover, polished black or pewter effect ring, matte black lens.

Hub included - standard 3/4" taper

Ø = 350 mm (13.8")

Depth = 82 mm (3.22")



**Dolfin L B/B/B**



**Dolfin L B/B/Pw**



**Dolfin L B/SS/B**



**Dolfin V B/SS/B**

<b>Diameter</b>	350 mm (13.8")
<b>Grip material</b>	Leather or vinyl
<b>Grip color</b>	Black
<b>Spokes</b>	316L SS polished or black
<b>Center cap</b>	Black
<b>Floating cap</b>	Available upon request
<b>Standard 3/4" hub</b>	Included
<b>QDH hub</b>	n.a.
<b>Certifications &amp; standards</b>	CE, UKCA, NMMA; ISO 23411 & ABYC P22

<b>Dolfin L B/B/B</b>	23023T	Black leather grip, SS black spokes with black inserts, black painted cover
<b>Dolfin L B/SS/B</b>	69562J	Black leather grip, SS polished spokes with black inserts, black painted cover
<b>Dolfin V B/SS/B</b>	69561G	Black vinyl grip, SS polished spokes with black inserts, black painted cover
<b>Dolfin L B/B/Pw</b>	23591H	Black leather grip, SS black spokes with pewter look painted inserts, black painted cover

**Vivaldi**  
Vero Volante Italiano



VERO VOLANTE ITALIANO



  
CHRISTIANGRANDE  
DesignWorks

Vivaldi L B/L/L

3-spoke steering wheel.  
Polished 304 stainless steel spokes.  
Hand-stitching leather or vinyl or leather look polyurethane grip.  
Leather or painted cover, leather or stainless steel center cap.

Hub included - standard 3/4" taper

Ø = 350 mm (13.8")

Depth = 95 mm (3.74")





**Vivaldi L B/L/L**



**Vivaldi V B/B/L**



**Vivaldi PU B/B/L**



**Vivaldi V W/W/SS**

<b>Diameter</b>	350 mm (13.8")
<b>Grip material</b>	Leather, or vinyl, or leather look polyurethane
<b>Grip color</b>	Black or white
<b>Spokes</b>	Polished 304 stainless steel
<b>Center cap</b>	Leather or stainless steel
<b>Floating cap</b>	Available upon request
<b>Standard 3/4" hub</b>	Included
<b>QDH hub</b>	n.a.
<b>Certifications &amp; standards</b>	CE, UKCA, NMMA; ISO 23411 & ABYC P22

<b>Model</b>	<b>Part No.</b>	<b>Description</b>
<b>Vivaldi L B/L/L</b>	24721Z	Black leather grip, SS spokes, black leather cover
<b>Vivaldi V B/B/L</b>	24723D	Black vinyl grip, SS spokes, black painted cover
<b>Vivaldi PU B/B/L</b>	24724F	Black polyurethane grip, SS spokes, black painted cover
<b>Vivaldi V W/W/SS</b>	24722B	White vinyl grip, SS spokes, white painted cover





VERO VOLANTE ITALIANO



  
CHRISTIANGRANDE  
DesignWorks

**Morosini L B/CH/L**

3-spoke steering wheel.

Polished 304 stainless steel spokes.

Grip is available in:

- Hand-stitching leather
- Hand-stitching vinyl
- Mahogany
- Leather look polyurethane.

Chrome plated or painted cover, leather or painted or burl wood center cap.

Hub included - standard 3/4" taper

**Ø = 350 mm (13.8")**

**Depth = 81 mm (3.19")**



**Morosini L B/CH/L**



**Morosini V B/CH/L**



**Morosini PU B/CH/V**



**Morosini L C/P/P**

<b>Diameter</b>	350 mm (13.8")
<b>Grip material</b>	Leather or vinyl or mahogany or leather look polyurethane
<b>Grip color</b>	Black, gray, white, cream, mahogany
<b>Spokes</b>	Polished 304 stainless steel
<b>Center cap</b>	Leather or vinyl or painted or burl wood
<b>Floating cap</b>	n.a.
<b>Standard 3/4" hub</b>	Included
<b>QDH hub</b>	Available upon request*
<b>Certifications &amp; standards</b>	CE, UKCA, NMMA; ISO 23411 & ABYC P22

<b>Model</b>	<b>Part No.</b>	<b>Description</b>
<b>Morosini L B/CH/L</b>	67297F	Black leather grip, SS spokes, chrome plated cover
<b>Morosini V B/CH/L</b>	68000H	Black vinyl grip, SS spokes, chrome plated cover
<b>Morosini PU B/CH/V</b>	67461S	Black polyurethane grip, SS spokes, chrome plated cover
<b>Morosini L C/P/P</b>	67299K	Cream leather grip, SS spokes, cream painted cover

\* To be specified when ordering the wheel



VERO VOLANTE ITALIANO



  
CHRISTIANGRANDE  
DesignWorks

**Morosini M/CH/BR**

3-spoke steering wheel.

Polished 304 stainless steel spokes.

Grip is available in:

- Hand-stitching leather
- Hand-stitching vinyl
- Mahogany
- Leather look polyurethane.

Chrome plated or painted cover, leather or painted or burl wood center cap.

Hub included - standard 3/4" taper

**Ø = 350 mm (13.8")**

**Depth = 81 mm (3.19")**



**Morosini M/CH/BR**



**Morosini L W/P/P - Morosini V W/P/P**



**Morosini L G/CH/L**



**Morosini V G/CH/L**

<b>Diameter</b>	350 mm (13.8")
<b>Grip material</b>	Leather or vinyl or mahogany or leather look polyurethane
<b>Grip color</b>	Black, gray, white, cream, mahogany
<b>Spokes</b>	Polished 304 stainless steel
<b>Center cap</b>	Leather or vinyl or painted or burl wood
<b>Floating cap</b>	n.a.
<b>Standard 3/4" hub</b>	Included
<b>QDH hub</b>	Available upon request*
<b>Certifications &amp; standards</b>	CE, UKCA, NMMA; ISO 23411 & ABYC P22

<b>Model</b>	<b>Part No.</b>	<b>Description</b>
<b>Morosini M/CH/BR</b>	68378L	Mahogany grip, SS spokes, chrome plated cover
<b>Morosini L W/P/P</b>	67298H	White leather grip, SS spokes, white painted cover
<b>Morosini V W/P/P</b>	68831E	White vinyl grip, SS spokes, white painted cover
<b>Morosini L G/CH/L</b>	67300R	Gray leather grip, SS spokes, chrome plated cover
<b>Morosini V G/CH/L</b>	68830C	Gray vinyl grip, SS spokes, chrome plated cover

\* To be specified when ordering the wheel

**Gritti**  
**Vero Volante Italiano**



VERO VOLANTE ITALIANO



**Gritti Carbon LC B/SS/B**

3-spoke steering wheel.  
Polished 304 stainless steel spokes.  
Hand-stitching leather grip with inserts in alutec or carbon.  
chrome plated cover, leather center cap.

Hub included - standard 3/4" taper

**Ø = 350 mm (13.8")**

**Depth = 86 mm (3.4")**





**Gritti Alutec LA B/SS/B**



**Gritti Carbon LC B/SS/B**



**Gritti Carbon LC B/SS/R**

<b>Diameter</b>	350 mm (13.8")
<b>Grip material</b>	Leather and alutec or leather and carbon
<b>Grip color</b>	Black
<b>Spokes</b>	Polished 304 stainless steel
<b>Center cap</b>	Leather
<b>Floating cap</b>	Available upon request.
<b>Standard 3/4" hub</b>	Included
<b>QDH hub</b>	n.a.
<b>Certifications &amp; standards</b>	CE, UKCA, NMMA; ISO 23411 & ABYC P22

<b>Model</b>	<b>Part No.</b>	<b>Description</b>
<b>Gritti LA B/SS/B</b>	24720X	Black perforated leather and alutec grip, SS spokes, chrome plated cover
<b>Gritti LC B/SS/B</b>	24719N	Black leather and glossy carbon grip, SS spokes, chrome plated cover
<b>Gritti LC B/SS/R</b>	24921H	Black leather with red stitches and matt carbon grip, SS spokes,





VERO VOLANTE ITALIANO



  
CHRISTIANGRANDE  
DesignWorks

**Foscari V B/R**

3-spoke steering wheel.  
Polished 304 stainless steel spokes.  
Hand-stitching vinyl or leather look polyurethane grip.  
Stainless steel cover, stainless steel center cap.

Hub included - standard 3/4" taper

**Ø = 350 mm (13.8")**

**Depth = 81 mm (3.19")**



**Foscari V B/R**



**Foscari PU B**



**Foscari PU W**



**Foscari PU C**

<b>Diameter</b>	350 mm (13.8")
<b>Grip material</b>	Vinyl or leather look polyurethane
<b>Grip color</b>	Black, white, cream
<b>Spokes</b>	Polished 304 stainless steel
<b>Center cap</b>	Stainless steel
<b>Floating cap</b>	n.a.
<b>Standard 3/4" hub</b>	Included
<b>QDH hub</b>	Available upon request*
<b>Certifications &amp; standards</b>	CE, UKCA, NMMA; ISO 23411 & ABYC P22

\* To be specified when ordering the wheel

<b>Model</b>	<b>Part No.</b>	<b>Description</b>
<b>Foscari V B/R</b>	21552L	Black vinyl grip, red stitches, SS spokes, SS cover
<b>Foscari PU B</b>	67303X	Black polyurethane grip, SS spokes, SS cover
<b>Foscari PU W</b>	67302V	White polyurethane grip, SS spokes, SS cover
<b>Foscari PU C</b>	67304Z	Cream polyurethane grip, SS spokes, SS cover

## Adorno Vero Volante Italiano



VERO VOLANTE ITALIANO



Adorno L B/CH

3-spoke steering wheel.  
Polished 304 stainless steel spokes.  
Hand-stitching leather or leather look polyurethane grip.  
Stainless steel cover, polished stainless steel center cap.

Hub included - standard 3/4" taper

Ø = 350 mm (13.8")

Depth = 81 mm (3.19")



**Adorno L B/CH**



**Adorno PU B/CH**



<b>Diameter</b>	350 mm (13.8")
<b>Grip material</b>	Leather or leather look polyurethane
<b>Grip color</b>	Black
<b>Spokes</b>	Polished 304 stainless steel
<b>Center cap</b>	Polished stainless steel
<b>Floating cap</b>	Available upon request*
<b>Standard 3/4" hub</b>	Included
<b>QDH hub</b>	Available upon request
<b>Certifications &amp; standards</b>	CE, UKCA, NMMA; ISO 23411 & ABYC P22

<b>Model</b>	<b>Part No.</b>	<b>Description</b>
<b>Adorno L B/CH</b>	69169G	Black leather grip, SS spokes, SS cover
<b>Adorno PU B/CH</b>	69167C	Black polyurethane grip, SS spokes, SS cover

\* To be specified when ordering the wheel

## Imperiale Vero Volante Italiano



VERO VOLANTE ITALIANO



Imperiale V B/SS/P

3-spoke steering wheel.

Available spokes:

- Brushed 316L stainless steel with polished edges
- Brushed silver anodized aluminum with polished edges

Hand-stitching vinyl or leather look polyurethane grip.

Black painted cover, chrome plated center cap.

Hub included - standard 3/4" taper

Ø = 350 mm (13.8")

Depth = 68 mm (2.68")





**Imperiale V B/SS/P**



**Imperiale PU B/S/P**



<b>Diameter</b>	350 mm (13.8")
<b>Grip material</b>	Vinyl or leather look polyurethane
<b>Grip color</b>	Black
<b>Spokes</b>	Brushed 316L SS or brushed silver aluminum
<b>Center cap</b>	Chrome plated
<b>Floating cap</b>	n.a.
<b>Standard 3/4" hub</b>	Included
<b>QDH hub</b>	n.a.
<b>Certifications &amp; standards</b>	CE, UKCA, NMMA; ISO 23411 & ABYC P22

<b>Model</b>	<b>Part No.</b>	<b>Description</b>
<b>Imperiale V B/SS/P</b>	21299B	Black vinyl grip, brushed SS spokes with polished edges, black painted cover
<b>Imperiale PU B/S/P</b>	21300G	Black polyurethane grip, brushed aluminum spokes with polished edges, black painted cover



## Manin Vero Volante Italiano



VERO VOLANTE ITALIANO



Manin PU B/S

3-spoke steering wheel.  
Polished 304 stainless steel or silver or black anodized aluminum spokes.  
Leather look polyurethane grip.  
Chrome plated cover and center cap.

Hub included - standard 3/4" taper

Ø = 350 mm (13.8")

Depth = 90 mm (3.54")



**Manin PU B/SS**



**Manin PU B/S**



**Manin PU B/B/VE**



**Manin PU B/SS/VE**

<b>Diameter</b>	350 mm (13.8")
<b>Grip material</b>	Leather look polyurethane
<b>Grip color</b>	Black
<b>Spokes</b>	Polished 304 SS or silver or black aluminum
<b>Center cap</b>	Chrome plated or black and silver painted
<b>Floating cap</b>	Available upon request
<b>Standard 3/4" hub</b>	Included
<b>QDH hub</b>	Available upon request*
<b>Certifications &amp; standards</b>	CE, UKCA, NMMA; ISO 23411 & ABYC P22

\* To be specified when ordering the wheel

Model	Part No.	Description
<b>Manin PU B/SS</b>	68204A	Black polyurethane grip, SS spokes, chrome plated cover
<b>Manin PU B/S</b>	68205C	Black polyurethane grip, silver aluminum spokes, chrome plated cover
<b>Manin PU B/B/VE</b>	25934Y	Black polyurethane grip, black aluminum spokes, chrome plated cover
<b>Manin PU B/SS/VE</b>	25933W	Black polyurethane grip, SS polished spokes, black and silver painted cover



VERO VOLANTE ITALIANO



**Grimani PU B/S/VE**

3-spoke steering wheel.  
Polished 304 stainless steel or silver or black anodized aluminum spokes.  
Leather look polyurethane grip with silver, chrome plated or matte black inserts.  
Black painted and chrome plated, silver and chrome plated or black and matte black cover and black painted center cap.

Hub included - standard 3/4" taper

**Ø = 350 mm (13.8")**

**Depth: 90 mm (3.54")**



**Grimani PU B/SS/CH**



**Grimani PU B/S/VE**



**Grimani PU B/B/CH**



**Grimani PU B/B/PB**

<b>Diameter</b>	350 mm (13.8")
<b>Grip material</b>	Leather look polyurethane with inserts
<b>Grip color</b>	Black with silver or chrome plated or matte black inserts
<b>Spokes</b>	Polished 304 SS or silver or black aluminum
<b>Center cap</b>	Black painted
<b>Floating cap</b>	Available upon request
<b>Standard 3/4" hub</b>	Included
<b>QDH hub</b>	Available upon request*
<b>Certifications &amp; standards</b>	CE, UKCA, NMMA; ISO 23411 & ABYC P22

\* To be specified when ordering the wheel

Model	Part No.	Description
<b>Grimani PU B/SS/CH</b>	69198P	Black polyurethane grip with chrome plated inserts, SS spokes, black painted and chrome plated cover
<b>Grimani PU B/S/VE</b>	69297S	Black polyurethane grip with silver inserts, silver aluminum spokes, black painted and silver painted cover
<b>Grimani PU B/B/CH</b>	69298U	Black polyurethane grip with chrome plated inserts, black aluminum spokes, black painted and chrome plated cover
<b>Grimani PU B/B/PB</b>	25936C	Black polyurethane grip with matte black inserts, black aluminum spokes, black painted and black cover



VERO VOLANTE ITALIANO



**Grimani PU B/S/R**

3-spoke steering wheel.  
Silver or black anodized aluminum spokes.  
Leather look polyurethane grip with color painted inserts.  
Black and color painted cover and black painted center cap.

Hub included - standard 3/4" taper

**All Grimani wheels can be supplied with inserts in the following colors:**

- **Blue**
- **Red**
- **Green**
- **Purple**
- **Orange**
- **Yellow**
- **White**

Ø = 350 mm (13.8")

Depth = 90 mm (3.54")





**Grimani PU B/S/BL**



**Grimani PU B/S/R**



**Grimani PU B/S/KG**



**Grimani PU B/S/Y**



**Grimani PU B/S/O**



**Grimani PU B/S/PL**

<b>Diameter</b>	350 mm (13.8")
<b>Grip material</b>	Leather look polyurethane with inserts
<b>Grip color</b>	Black with chrome plated or color painted inserts
<b>Spokes</b>	Polished 304 SS or silver aluminum
<b>Center cap</b>	Black painted
<b>Floating cap</b>	Available upon request
<b>Standard 3/4" hub</b>	Included
<b>QDH hub</b>	Available upon request*
<b>Certifications &amp; standards</b>	CE, UKCA, NMMA; ISO 23411 & ABYC P22

\* To be specified when ordering the wheel

Model	Part No.	Description
<b>Grimani PU B/S/VE</b>	69297S	Black PUR grip with silver inserts, silver Al spokes, black and silver painted cover
<b>Grimani PU B/S/BL</b>	69480G	Black PUR grip with blue inserts, silver Al spokes, black and blue painted cover
<b>Grimani PU B/S/R</b>	69481J	Black PUR grip with red inserts, silver Al spokes, black and red painted cover
<b>Grimani PU B/S/KG</b>	20836W	Black PUR grip with green inserts, silver Al spokes, black and green painted cover
<b>Grimani PU B/S/Y</b>	69482L	Black PUR grip with yellow inserts, silver Al spokes, black and yellow painted cover
<b>Grimani PU B/S/O</b>	20671P	Black PUR grip with orange inserts, silver Al spokes, black and orange painted cover
<b>Grimani PU B/S/PL</b>	69483N	Black PUR grip with purple inserts, silver Al spokes, black and purple painted cover
<b>Grimani PU B/S/W</b>	20600P	Black PUR grip with white inserts, silver Al spokes, black and white painted cover





VERO VOLANTE ITALIANO



**Grimani PU B/S/VE no cover**

3-spoke steering wheel.

Silver or black anodized aluminum or polished 304 stainless steel spokes.  
Leather look polyurethane grip with chrome plated or color painted inserts.  
Hub included - standard 3/4" taper

**All Grimani wheels can be supplied with stainless steel spokes and inserts in the following colors:**

- **Blue**
- **Red**
- **Green**
- **Purple**
- **Orange**
- **Yellow**
- **White**

Ø = 350 mm (13.8")

Depth = 90 mm (3.54")



**Grimani PU B/S/BL no cover**



**Grimani PU B/S/R no cover**



**Grimani PU B/S/KG no cover**

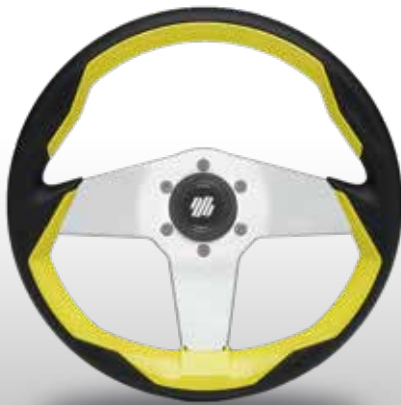

**Grimani PU B/S/Y no cover**



**Grimani PU B/S/O no cover**



**Grimani PU B/S/PL no cover**

<b>Diameter</b>	350 mm (13.8")
<b>Grip material</b>	Leather look polyurethane with inserts
<b>Grip color</b>	Black with chrome plated or color painted inserts
<b>Spokes</b>	Silver anodized aluminum
<b>Center cap</b>	Black painted
<b>Floating cap</b>	n.a.
<b>Standard 3/4" hub</b>	Included
<b>QDH hub</b>	Available upon request*
<b>Certifications &amp; standards</b>	CE, UKCA, NMMA; ISO 23411 & ABYC P22

\* To be specified when ordering the wheel

Model	Part No.	Description
<b>Grimani PU B/S/VE no cover</b>		Black PUR grip with silver inserts, silver Al spokes
<b>Grimani PU B/S/BL no cover</b>	21227Z	Black PUR grip with blue inserts, silver Al spokes
<b>Grimani PU B/S/R no cover</b>	21228B	Black PUR grip with red inserts, silver Al spokes
<b>Grimani PU B/S/KG no cover</b>	20941T	Black PUR grip with green inserts, silver Al spokes
<b>Grimani PU B/S/Y no cover</b>	21229D	Black PUR grip with yellow inserts, silver Al spokes
<b>Grimani PU B/S/O no cover</b>	21231P	Black PUR grip with orange inserts, silver Al spokes
<b>Grimani PU B/S/PL no cover</b>	21230M	Black PUR grip with purple inserts, silver Al spokes
<b>Grimani PU B/S/W no cover</b>	21232S	Black PUR grip with white inserts, silver Al spokes

## Loredan Vero Volante Italiano



VERO VOLANTE ITALIANO



Loredan PU B/S/CH

3-spoke steering wheel.

Silver or black aluminum or polished 304 stainless steel spokes.

Leather look polyurethane grip with chrome plated or color painted inserts.

Available with or without cover.

Black painted and chrome plated cover and black painted center cap (excluded no cover versions).

Hub included - standard 3/4" taper

**All Loredan wheels can be supplied with stainless steel spokes and inserts in the following colors:**

- Blue
- Red
- Green
- Purple
- Orange
- Yellow
- White

Ø = 350 mm (13.8")

Depth = 92,5 mm (3.64")

new



Loredan PU B/B/PB



Loredan PU B/S/BL



Loredan PU B/S/CH no cover

Diameter	350 mm (13.8")
Grip material	Leather look polyurethane with inserts
Grip color	Black with chrome plated or color painted inserts
Spokes	Silver or black aluminum or polished 304 SS
Center cap	Black painted
Floating cap	Available upon request*
Standard 3/4" hub	Included
QDH hub	Available upon request
Certifications & standards	CE, UKCA, NMMA; ISO 23411 & ABYC P22

\* To be specified when ordering the wheel



Model	Part No.	Description
Loredan PU B/S/CH	69558U	Black PUR grip with silver inserts, silver Al spokes, black and silver painted cover
Loredan PU B/S/BL	20039T	Black PUR grip with blue inserts, silver Al spokes, black and blue painted cover
Loredan PU B/S/R	20041D	Black PUR grip with red inserts, silver Al spokes, black and red painted cover
Loredan PU B/S/KG	20837Y	Black PUR grip with green inserts, silver Al spokes, black and green painted cover
Loredan PU B/S/Y	20342U	Black PUR grip with yellow inserts, silver Al spokes, black and yellow painted cover
Loredan PU B/S/O	20673U	Black PUR grip with orange inserts, silver Al spokes, black and orange painted cover
Loredan PU B/S/PL	20040B	Black PUR grip with purple inserts, silver Al spokes, black and purple painted cover
Loredan PU B/S/W	20601S	Black PUR grip with white inserts, silver Al spokes, black and white painted cover
Loredan PU B/B/PB	25937E	Black polyurethane grip with polished inserts, black aluminum spokes, black painted and black cover

Model	Part No.	Description
Loredan PU B/S/CH no cover	20942V	Black PUR grip with silver inserts, silver Al spokes
Loredan PU B/S/BL no cover	21234W	Black PUR grip with blue inserts, silver Al spokes
Loredan PU B/S/R no cover	20943X	Black PUR grip with red inserts, silver Al spokes
Loredan PU B/S/KG no cover	21235K	Black PUR grip with green inserts, silver Al spokes
Loredan PU B/S/Y no cover	21237C	Black PUR grip with yellow inserts, silver Al spokes
Loredan PU B/S/O no cover	21236A	Black PUR grip with orange inserts, silver Al spokes
Loredan PU B/S/PL no cover	21239G	Black PUR grip with purple inserts, silver Al spokes
Loredan PU B/S/W no cover	21238E	Black PUR grip with white inserts, silver Al spokes

**Doria**  
Vero Volante Italiano



VERO VOLANTE ITALIANO



**Doria PU B/S/R**

3-spoke steering wheel.  
Silver painted spokes, leather look polyurethane grip with chrome plated or color painted inserts and painted center cap.

Hub included - standard 3/4" taper

**Ø = 350 mm (13.8")**

**Depth = 74 mm (2.91")**





**Doria PU B/S/R**



**Doria PU B/S/B**



**Doria PU B/CH/CH**

<b>Diameter</b>	350 mm (13.8")
<b>Grip material</b>	Leather look polyurethane with inserts
<b>Grip color</b>	Black with color painted or chrome plated inserts
<b>Spokes</b>	Silver or chrome plated
<b>Center cap</b>	Painted
<b>Floating cap</b>	n.a.
<b>Standard 3/4" hub</b>	Included
<b>QDH hub</b>	n.a.
<b>Certifications &amp; standards</b>	CE, UKCA, NMMA; ISO 23411 & ABYC P22

<b>Model</b>	<b>Part No.</b>	<b>Description</b>
<b>Doria PU B/S/R</b>	67309K	Black polyurethane grip with painted red inserts, silver painted spokes
<b>Doria PU B/S/B</b>	67465A	Black polyurethane grip with painted black inserts, silver painted spokes
<b>Doria PU B/CH/CH</b>	69706G	Black polyurethane grip with chrome plated inserts, chrome plated spokes



## Falier Vero Volante Italiano



VERO VOLANTE ITALIANO



Falier V B/BRU/L

5-spoke steering wheel.  
Brushed 316L stainless steel spokes.  
Vinyl or leather look polyurethane grip  
polished stainless steel cover, leather or painted center cap.

Hub included - standard 3/4" taper

Ø = 350 mm (13.8")

Depth = 84 mm (3.3")



**Falier V B/BRU/L**



**Falier PU B/BRU/B**



**Falier PU G/BRU/G**

<b>Diameter</b>	350 mm (13.8")
<b>Grip material</b>	Vinyl or leather look polyurethane
<b>Grip color</b>	Black, gray
<b>Spokes</b>	Brushed 316L stainless steel
<b>Center cap</b>	Leather or painted
<b>Floating cap</b>	Available upon request.*
<b>Standard 3/4" hub</b>	Included
<b>QDH hub</b>	n.a.
<b>Certifications &amp; standards</b>	CE, UKCA, NMMA; ISO 23411 & ABYC P22

Model	Part No.	Description
<b>FALIER V B/BRU/L</b>	24733G	Black vinyl grip with gray stitches, SS brushed spokes, SS polished cover
<b>FALIER PU B/BRU/B</b>	24734J	Black polyurethane grip, SS brushed spokes, SS polished cover
<b>FALIER PU G/BRU/G</b>	24735L	Gray polyurethane grip, SS brushed spokes, SS polished cover

\* To be specified when ordering the wheel

## Captiva HU/B - Heated steering wheel Vero Volante Italiano



VERO VOLANTE ITALIANO



Captiva HU/B

- Power switch embedded in the spoke
- Two available heating modes: COMFORT and HIGH
- Sliding contacts power supply
- LED dimmer (day/night)
- Low voltage monitoring and disconnection
- 12V DC and 24V DC power supply (50 W draw)
- Fits all front mount Ultraflex and Seastar™ hydraulic helms.
- Fits Ultraflex electronic tilt helms
- Fits all Ultraflex tilt mechanisms, featuring internal routing of the wire
- IP65 rated.
- Compatible with knob SK-25458S
- Patented

Hub included - standard 3/4" taper  
Center nut available as spare part

Ø = 350 mm (13.8")

Depth = 85 mm (3.34")

## Captiva HU/B - Heated steering wheel Vero Volante Italiano



**Captiva HU/B**



<b>Diameter</b>	350 mm (13.8")
<b>Frame</b>	Front: polished 316L stainless steel; Rear: black TPU
<b>Spokes</b>	Polished 316L stainless steel and TPU with black methacrylate inserts
<b>Center Nut</b>	Polished stainless steel
<b>Standard 3/4" hub</b>	Included
<b>QDH hub</b>	n.a.
<b>Certifications &amp; standards</b>	CE, UKCA, NMMA; ISO 23411 & ABYC P22

<b>Model</b>	<b>Part No.</b>	<b>Description</b>
<b>Captiva HU/B</b>	24995P	Heated steering wheel, SS front grip and TPU rear grip, stainless steel and TPU spokes with black methacrylate inserts,

## Captiva BK - Captiva B

Vero Volante Italiano



VERO VOLANTE ITALIANO



Captiva BK

3-spoke steering wheel, available with incorporated knob or without knob.  
Polished 316L stainless steel and black TPU spokes with black methacrylate inserts.  
Polished 316L stainless steel front grip, black TPU rear grip.  
Polished stainless steel center nut (available as spare part).  
Captiva B is compatible with **Knob SK 25458S** as retrofit.

Hub included - standard 3/4" taper

Ø = 350 mm (13.8")

Depth = 85 mm (3.34")





**Captiva B**



**Captiva BK**



**Captiva B + Knob SK**



<b>Diameter</b>	350 mm (13.8")
<b>Frame</b>	Front: polished 316L stainless steel; Rear: Black TPU
<b>Spokes</b>	Polished 316L stainless steel and TPU with black methacrylate inserts
<b>Center Nut</b>	Polished stainless steel
<b>Standard 3/4" hub</b>	Included
<b>QDH hub</b>	n.a.
<b>Certifications &amp; standards</b>	CE, UKCA, NMMA; ISO 23411 & ABYC P22

<b>Model</b>	<b>Part No.</b>	<b>Description</b>
<b>Captiva BK</b>	25883H	SS and TPU grip, stainless steel and TPU spokes with black methacrylate inserts, incorporated knob
<b>Captiva B</b>	24884K	SS and TPU grip, stainless steel and TPU spokes with black methacrylate inserts
<b>Knob SK</b>	25458S	Speed knob for Captiva B steering wheel



**Captiva GK - Captiva G - Captiva SFK - Captiva SF**  
**Vero Volante Italiano**



VERO VOLANTE ITALIANO



**Captiva G**

3-spoke steering wheel, available with incorporated knob or without knob.  
Polished 316L stainless steel and black TPU spokes with painted ABS inserts.  
Polished 316L stainless steel front grip, black TPU rear grip.  
Polished stainless steel center nut (available as spare part).

Hub included - standard 3/4" taper

**Ø = 350 mm (13.8")**

**Depth = 85 mm (3.34")**

# Captiva GK - Captiva G - Captiva SFK - Captiva SF

Vero Volante Italiano



**Captiva G**



**Captiva GK**



**Captiva SF**



**Captiva SFK**

<b>Diameter</b>	350 mm (13.8")
<b>Frame</b>	Front: polished 316L stainless steel; Rear: black TPU
<b>Spokes</b>	Polished 316L stainless steel and TPU with colored ABS inserts
<b>Center Nut</b>	Polished stainless steel
<b>Standard 3/4" hub</b>	Included
<b>QDH hub</b>	n.a.
<b>Certifications &amp; standards</b>	CE, UKCA, NMMA; ISO 23411 & ABYC P22

<b>Model</b>	<b>Part No.</b>	<b>Description</b>
<b>Captiva GK</b>	25851U	SS and TPU grip, stainless steel and TPU spokes with gray painted ABS inserts incorporated knob
<b>Captiva G</b>	25853Y	SS and TPU grip, stainless steel and TPU spokes with gray painted ABS inserts
<b>Captiva SFK</b>	25850S	SS and TPU grip, stainless steel and TPU spokes with seafoam painted ABS inserts incorporated knob
<b>Captiva SF</b>	25852W	SS and TPU grip, stainless steel and TPU spokes with seafoam painted ABS inserts.



VERO VOLANTE ITALIANO



**Contarini TPU/SS**

3-spoke steering wheel.  
Polished 316L stainless steel spokes.  
Polished 316L stainless steel and TPU grip.  
Stainless steel cover, black painted center cap.

Hub included - standard 3/4" taper

**Ø = 350 mm (13.8")**

**Depth = 79,5 mm (3.13")**



**Contarini TPU/SS**



**Contarini TPU/SS with KNOB SK**



<b>Diameter</b>	350 mm (13.8")
<b>Grip material</b>	TPU and polished 316L stainless steel
<b>Grip color</b>	Black and polished stainless steel
<b>Spokes</b>	Polished 316L stainless steel
<b>Center cap</b>	Black painted
<b>Floating cap</b>	n.a.
<b>Standard 3/4" hub</b>	Included
<b>QDH hub</b>	n.a.
<b>Certifications &amp; standards</b>	CE, UKCA, NMMA; ISO 23411 & ABYC P22

<b>Model</b>	<b>Part No.</b>	<b>Description</b>
<b>Contarini TPU/SS</b>	69199S	Black TPU and SS grip, SS spokes, SS cover
<b>Knob SK</b>	25458S	Speed knob for Contarini steering wheel

## Siestakey Vero Volante Italiano



VERO VOLANTE ITALIANO



Siestakey/B

2-spoke steering wheel.  
Polished 316L stainless steel and TPU spokes.  
Polished 316L stainless steel and black TPU grip.  
Black cover, black center cap.

Hub included - standard 3/4" taper

Ø = 368 mm (14.5")

Depth = 90 mm (3.54")





**SiestaKey B**



**SiestaKey B with KNOB SK**



<b>Diameter</b>	368 mm (14.5")
<b>Grip material</b>	Polished 316L stainless steel and TPU
<b>Grip color</b>	Polished stainless steel and black TPU
<b>Spokes</b>	Polished 316L stainless steel
<b>Cover</b>	Black
<b>Floating cap</b>	n.a.
<b>Standard 3/4" hub</b>	Included
<b>QDH hub</b>	n.a.
<b>Certifications &amp; standards</b>	CE, UKCA, NMMA; ISO 23411 & ABYC P22

<b>Model</b>	<b>Part No.</b>	<b>Description</b>
<b>SiestaKey B</b>	68188F	SS and black TPU grip, SS spokes, black cover
<b>Knob SK</b>	25458S	Speed knob for SiestaKey steering wheel



**Keywest**  
Vero Volante Italiano



VERO VOLANTE ITALIANO



**Keywest BLCK**

Carbon fiber 3-spoke wheel.  
Available with incorporated knob or without knob.  
Black TPU rear grip.

Hub included - standard da 3/4" taper.

Ø = 350 mm (13.8")

Depth = 96 mm (3.77")



**Keywest BLCK**



**Keywest PCK**



**Keywest BLC**



**Keywest PC**

<b>Diameter</b>	350 mm (13.8")
<b>Frame</b>	Carbon fiber
<b>Grip material</b>	Polished blue and polished carbon fiber and TPU.
<b>Spokes</b>	Carbon fiber and TPU
<b>Floating cap</b>	n.a.
<b>Standard 3/4" hub</b>	Included
<b>QDH hub</b>	n.a.
<b>Certifications &amp; standards</b>	CE, UKCA, NMMA; ISO 23411 & ABYC P22

<b>Model</b>	<b>Part No.</b>	<b>Description</b>
<b>Keywest BLCK</b>	25481L	Polished blue carbon fiber and TPU grip and spokes. Knob included
<b>Keywest PCK</b>	25479A	Polished carbon fiber and TPU grip and spokes. Knob included
<b>Keywest BLC</b>	25484T	Polished blue carbon fiber and TPU grip and spokes.
<b>Keywest PC</b>	25482N	Polished carbon fiber and TPU grip and spokes.

**new**



VERO VOLANTE ITALIANO



**Keywest BLCK**

Carbon fiber 3-spoke wheel.  
Available with incorporated knob or without knob.  
Black TPU rear grip.

Hub included - standard da 3/4" taper.

Ø = 350 mm (13.8")

Depth = 96 mm (3.77")



Keywest GRCK



Keywest PCBCK



Keywest MCK

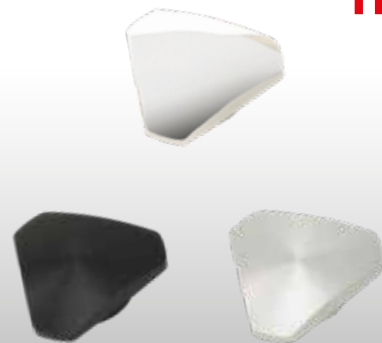

Keywest nut

Diameter	350 mm (13.8")
Frame	Carbon fiber
Grip material	Polished green and polished or matt carbon fiber.
Spokes	Carbon fiber and TPU
Floating cap	n.a.
Standard 3/4" hub	Included
QDH hub	n.a.
Certifications & standards	CE, UKCA, NMMA; ISO 23411 & ABYC P22

Model	Part No.	Description
Keywest GRCK	25887S	Polished green carbon fiber and TPU grip and spokes. Knob included
Keywest PCBCK	25888U	Polished forged carbon fiber and TPU grip and spokes. Knob included
Keywest MCK	25480J	Matt carbon fiber and TPU grip and spokes. Knob included
Center Nut Black	25945D	Available as optional
Center Nut Silver	25944B	Available as optional
Center Nut Polished	25946F	Available as optional



## QDH - Quick Disconnect Hub Steering wheels accessories

QDH - Quick Disconnect Hub allows for easy removal of the steering wheel from the cockpit.

**QDH**      23013D    Quick disconnect hub for standard 3/4" taper

Suitable with Ultraflex® steering wheels: please refer to steering wheel application chart



**QDH**



### X63 - Standard Hub



**X63**      40119D    Standard Hub

Please refer to steering wheel application chart

### Protection cover



**Protection cover**      22824Z    Protection cover with Ultraflex logo

Also available with customized logo (minimum order quantity: 20 pieces)



**KNOB UST**



**KNOB21**



**KNOB V56**



**KNOB SK**

Model	Part No.	Knob suitable for the following steering wheels:
KNOB UST	21721H	Giannutri, Domino, Ustica, Levanzo, Montecristo, Imperiale PU
KNOB21	42371A	V25SS, V01SS, V10SS, V52, V24, V58, V74/40, V77/40
KNOB V56	23600F	V56, Morosini PU, Foscari PU, Adorno
KNOB SK	25458S	Contarini, Siestakey, Captiva



# Steering wheel accessories

## Application chart

X63	KNOB UST	KNOB21	KNOB V56	KNOB SK	
<p>CORSE, V15, MYKONOS, SANTORINI, NISIDA, PIANOSA, PALMARIA, CAPRAIA, PANTELLERIA, DOMINO, TAVOLARA, VIVARA, BUDELLI, USTICA, LEVANZO, MONTECRISTO, RAZZOLI, CAPRI, ASINARA GIANNUTRI GALLINARA GIGLIO</p>	<p>GIANNUTRI, DOMINO, USTICA, LEVANZO, MONTECRISTO, IMPERIALE PU</p>	<p>V25SS, V01SS, V10SS, V52, V24, V58, V74/40, V77/40,</p>	<p>V56, MOROSINI PU, FOSCARI PU, ADORNO</p>	<p>CONTARINI, SIESTAKEY CAPTIVA</p>	

# Steering wheel accessories

## Application chart

FLOATING CAP	QDH - QUICK DISCONNECT HUB	PADDLE TRIM WITH TILT	PADDLE TRIM WITH FRONT MOUNT HELM	FABRIC COVER
V15, RAZZOLI, MONTECRISTO, ODERICO, TRON, SPINOLA, DOLFIN, MANIN, GRIMANI, LOREDAN SORANZO, GUARCO, VIVALDI, GRITTI, FALIER, ASINARA, V19, VENDRAMIN, BARBARIGO	ASINARA, CORSE, V15, MYKONOS, SANTORINI, NISIDA, PIANOSA, PALMARIA, CAPRAIA, PANTELLERIA, GIANNUTRI, DOMINO, TAVOLARA, VIVARA, BUDELLI, USTICA, LEVANZO, MONTECRISTO, RAZZOLI, CAPRI, MOROSINI, FOSCARI, ADORNO, MANIN, GRIMANI, LOREDAN, FREGOSO, GIGLIO GALLINARA	ASINARA, FREGOSO, GRITTI, FALIER, GUARCO, CAPTIVA CORSE, V21, V01, V10, V24, V56, V70, V57, V35, V29, V66, V62, V15, SANTORINI, NISIDA, PIANOSA, PALMARIA, CAPRAIA, PANTELLERIA, DOMINO, TAVOLARA, VIVARA, BUDELLI, USTICA, LEVANZO, MONTECRISTO, ODERICO, IMPERIALE, DOLFIN, MOROSINI, FOSCARI, ADORNO, CONTARINI, SIESTAKEY, MANIN, GRIMANI, LOREDAN, DORIA	ASINARA, FREGOSO, GRITTI, SORANZO, GUARCO VIVALDI, FALIER V38, V60, V99, CORSE, V21, V25, V20, V01, V10, V24, V56, V70, V57, V35, V29, V66, V62, V15, SANTORINI, NISIDA, PIANOSA, PALMARIA, CAPRAIA, PANTELLERIA, DOMINO, TAVOLARA, VIVARA, BUDELLI, MONTECRISTO, RAZZOLI, BUCCANEGRA, ODERICO, TRON, SPINOLA, IMPERIALE, DOLFIN, MOROSINI, FOSCARI, ADORNO, CONTARINI, BALBI, GRIMANI, LOREDAN, DORIA KEYWEST V19, GIGLIO, BARBARIGO, MANNA, VENDRAMIN, V75	ASINARA, FREGOSO, GRITTI, SORANZO, GUARCO, CAPTIVA, VIVALDI, FALIER V38, V60, V99, CORSE, V21, V25, V20, V01, V10, V24, V56, V70, V57, V29, V66, V62, V15, SANTORINI, NISIDA, PIANOSA, CAPRAIA, DOMINO, TAVOLARA, VIVARA, BUDELLI, MONTECRISTO, RAZZOLI, BOCCANEGRA, ODERICO, TRON, SPINOLA, IMPERIALE, DOLFIN, MOROSINI, FOSCARI, ADORNO, CONTARINI, BALBI, GRIMANI, LOREDAN, DORIA KEYWEST V19, GIGLIO, BARBARIGO, MANNA, VENDRAMIN, V75

## Paddle Trim



For complete control of engine trim and tilt, trim tabs, jackplates, PowerPole(R) and other on board systems, the innovative Paddle Trim system is the answer.

Adaptable to existing front mount hydraulic and tilt helms, the Paddle Trim is ergonomically designed to allow the driver to make precise adjustments to the attitude of the boat or other systems without removing his hand from the steering wheel.

**PTS-1** - 43051L - Single paddle kit including one paddle and the brackets to attach to a tilt or to a front mount helm

**PTS-2** - 43052N - Two paddles and the brackets to attach it to a tilt or to a front mount helm



Single or dual



Adjustable positioning



Tilt or front mount

### Features

- Available both in single and dual versions (for either two equal or two different outputs).
- Both single or dual paddle can be positioned at various angles for the most comfortable choice.
- Equipped with one water proof "MOM.ON-OFF-MOM.ON" switch (2 switches on dual version).
- Max load 2 Amp @ 12VDC.
- Suitable for any kind of steering wheel dish. Max wheel dia. 400 mm (15.7").
- Easy to install on the following Ultraflex® steering systems:
  - front and tilt mount hydraulic helms
  - tilt mount mechanical helms
- Wiring harness, labels and mounting hardware kit are included. The mounting plate, which differs between front and tilt mount installation, is to be ordered separately.

### KTR kit

- Kit relay available **KTR** - 42860S:
  - It allows a Paddle Trim pair to control electrical loads up to 10 Amp (e.g. Trim Tabs Uflex®).
  - Easy to use and to install, through connectors with pre-crimped contacts.



KTR kit

## Paddle Trim labels

	ENGINE TRIM & TILT	JACKPLATE	TRIM TABS	HORN
UP				
DOWN				

## Order guide

DESCRIPTION	P. No	SINGLE QTY	DUAL QTY
- Single function control device	42857D	1	2
- Mounting plate for tilt mount helms (mech or hydraulic)	42858F	1	1
or:			
- Mounting plate for front mount hydraulic helms	42859H	1	1
- <b>KTR</b> kit relay for loads exceeding 5 Amp	42860S	1	2



## HANDLES

**new**

Handles with a comfortable grip made of stainless steel, stainless steel with inserts, polished carbon or matte carbon and PU.

Total length 500 mm (different sizes available)



H01	25940T	Stainless steel and PU handle
H02	25949M	Stainless steel handle and PU with insert
H03	25941V	Polished carbon handle
H04	25942X	Matte carbon handle

## Vero Volante Italiano The brand

“VERO VOLANTE ITALIANO” is the registered trademark which distinguishes the steering wheels for pleasure boats produced by Ultraflex.

They are conceived by Italian designers, engineered and manufactured in Italy by employing genuine Italian components and technologies according to Ultraflex quality management system.

All ULTRAFLEX steering wheels meet the directive 2013/53/ EU requirements about pleasure boats.

All steering wheels are CE marked in conformity with the EN 28848 – EN 29775 and ABYC P22 safety standards



VERO VOLANTE ITALIANO

## Vero Volante Italiano Maintenance

- Periodically clean the steering wheel to remove any salt deposit: rinse with fresh water and dry with a clean cloth
- Do not use any aggressive soap or alcohol based cleaner or solvent that may damage the steering wheel
- Use specific cleaning products on leather finished steering wheels; automotive leather equipment cleaners and cloths are the most indicated
- Always protect the steering wheel with its own canvas cover during non-use periods





# Power A Mark II™

## Electronic control system

### **Power A Mark II™**

- Private protocol CAN-bus for data transmission
- Suitable for mechanical shift and throttle as well as electronic Throttle and shift
- Connection of multiple stations up to 4 controls
- Modular system
- Direct communication with electronic engines (SAE J 1939 or NMEA 2000)
- Plug'n play connectivity
- Automatic engine synchronization
- Dock assist
- Fully programmable shift delays
- Personalized label upon request
- Available installation also for 3 or 4 engines\*

\*Please, contact our Technical Department for 3 or 4 engine installations.

Easy to install PowerA Mark II™ control system provides fingertip operation of throttle and shift levers.

Using reliable and precise digital data transmission, this single or dual function control system is specifically designed to work on mechanically controlled as well as electronic and electro-hydraulic gas and diesel inboards, sterndrives and outboards.

The PowerA Mark II™ comes with many features including Dock Assist, which offers the operator the opportunity to reduce the sensitivity of the throttle function for easier dockside handling.

Other standard features include RPM Synchronization, which reduces engine vibration and improves fuel economy, a High Idle feature to increase RPM where higher idle is necessary for cold engine operations, and provided our Technical Assistance, a programmable Trolling Valve Control and neutral Warm Up.

The stylish and ergonomically designed control makes the PowerA Mark II™ suitable for many types of applications ranging from sport boats, yachts and commercial applications.

Available with and without trim, the control has audible and visual interfaces which alert the operator to the current status of the control system.

With the ability to control up to 4 outboard engines from up to 4 different stations, the PowerA Mark II™ is a modular and flexible system with simple to install components.

The unique Control Unit Display of the PowerA Mark II™ provides simple touch pad programming with descriptive information regarding the set up, tuning and diagnostics of the system.

Power A Mark II is a system that can replace mechanical controls either on fully mechanical engines, or on fully electronic engines, or on engines with the combination of both characteristics.

#### **SAFETY DEVICES**

- Start in-gear PROTECTION(start inhibition with shifted gear)
- Audible and visual diagnostic failure alarm (READABLE MESSAGES ON THE CONTROL UNIT DISPLAY)
- Proportional shift delays
- Programmable working parameters
- Meets CEI EN 60945 standards

#### **Compatibility with all mechanical throttle engines**

#### **Compatibility with all electronic throttle engines**

- Cummins, Detroit Diesel, Scania, Iveco, FPT, Lombardini, VM Motori, FNM, Yanmar, CMD-Volkswagen, Hyundai etc.

Power A Mark II™ electronic system actuators cannot be installed in those rooms where ignition-proof devices are required.

## Power A Mark II™ Electronic control system

Control stations	up to 4
Control stations IP Protection	IP66
Power supply	min. 9V / Max 32V
Working temperature	-25°C to +75°C
Electronic throttle output voltage	double output 0 - 5V and or - 2,5V
Electronic throttle output PWM	0-100%, frequency from 200HZ to 1 KHZ
Electronic throttle output current	4 - 10MA
Digital throttle output	SAEJ 1939, NMEA 2000®
Trolling valve output voltage	0 - 5V
Trolling valve output PWM	0-100%, frequency from 100HZ to 1 KHZ
Trolling valve output current	4 - 20MA
Electric shift control	2 or 3 ON/OFF or proportional solenoids
Certifications	CEI EN60945 UNI-EN ISO 11547

The “Power A Mark II™ - Installation and User Manual” describes activities, operations, technical specifications which must be followed during the installation and/or usage of the product, in order to keep a valid warranty and obtain the better performance. Description and drawings in that manual are suitable to allow an easy installation and safe use of the product by skilled personnel. In case of doubt and/or for any information, please contact our Technical Service.

**PLEASE REFER TO LIMITED WARRANTY CONDITIONS REPORTED IN THIS CATALOGUE.**



# Power A Mark II™ Electronic control system

**Power A Mark II™**

CE UK  
CA

## STANDARD CONTROL STATIONS:

### Control without trim:

- Single engine - 42009G chrome
- Single engine - 42426Z black
- Twin engines - 42011T chrome
- Twin engines - 42425X black

IP protection: IP66



## STANDARD CONTROL STATIONS:

### Control with trim:

- Single engine - 42010R chrome
- Single engine - 42427B black
- Twin engines - 42012V chrome
- Twin engines - 42428D black

IP protection: IP66



**COMPACT CONTROL STATIONS:**

**Control without trim:**

Single engine - 43923V chrome

Twin engines - 43924X chrome

**IP protection: IP66**



**SAIL COMPACT CONTROL STATIONS**

Including **SAIL** function in order to stop the rotation of the shafting making the use of folding blade propellers more effective when sailing by reducing dragging and shaft sealing overstress”

The **SAIL** function can be activated only when the panel is turned off, commanding the actuator to shift into reverse.

**Control without trim:**

Single engine - 43923V chrome

Twin engines - 43924X chrome

**IP protection: IP66**



**new**

## Power A Mark II™ Modular components

Control Unit



**PA2-CU** - 42017F

**PA2-CU 4 engines Control Unit** - 43157D

Control Unit: user interface for the configuration, settings and diagnostic of all the modules in a system.

IP protection: IP65

Dim.: 8.5" x 4.7" (215 x 120 mm)

V-Throttle  
I-Throttle



**PA2-VT** - 42018H - for 0-5V interfaces (voltage)

**PA2-IT** - 42019K - for 4-20 mA interfaces (current)

They supply the throttle electronic signal. Required for use with direct connection to electronic throttle on the engine.

IP protection: IP65

Dim.: 8" x 4.3" (205 x 110 mm)

SAEJ-Throttle



**PA2-SAEJT** - Customized

It supplies the digital signals to CAN SAEJ 1939 or NMEA 2000 interfaces

IP protection: IP65

Dim.: 8" x 4.3" (205 x 110 mm)

PWM-Throttle



**PA2-PWMT** - 42020U

It supplies the electrical signals to PWM interfaces

IP protection: IP65

Dim.: 8" x 4.3" (205 x 110 mm)

## Shift Unit



### PA2-SU - 42023A

It controls up to 2 shifts with solenoids. Required for use with direct connection to the electrical shift unit on the transmission.

IP protection: IP65

Dim.: 8.3" x 4.7" (210 x 120 mm)

## Power Unit



### PA2-PU - 42026G

Provides power for up to 4 modules with the input combination of up to 2 batteries, 12 and 24V. Required for all PowerA Mark II installations.

IP protection: IP65

Dim.: 8" x 4.3" (205 x 110 mm)

## M-Actuator



### PA2-MA - 42027J

The electromechanical actuators can control any mechanical interface (throttle or shift) through MACHZero and C8 mechanical cables.

IP protection: IP66

Length: 12.6" (320 mm)



MODEL	P. No.	DESCRIPTION	FEATURES	No. OF ENGINES	ENGINE TYPE
V-Throttle	42018H	Throttle with analog voltage interface	Redundant voltage input, IVS.	1 - 2	FPT, Yanmar, Mercruiser, Lombardini.
V-Throttle	42437E	Throttle with analog voltage interface	Redundant voltage input, IVS.	1 - 2	Volkswagen
I-Throttle	42019K	Throttle with current analog interface	Current outputs.	1 - 2	4 - 20 mA throttle engines
PWM-Throttle	42020U	Throttle with PWM interface	PWM outputs	1 - 2	Perkins, Caterpillar
SAEJ-Throttle	Personalized	Throttle with SAEJ 1939 interface	CAN DeviceNet SAEJ 1939 outputs	1 - 2	SAEJ 1939 engines
NMEA-Throttle	Personalized	Throttle with NMEA 2000 interface	CAN DeviceNet NMEA 2000 outputs	1 - 2	NMEA 2000 engines

CHART B - Throttle cables

MODEL	APPLICATION	LENGTH (m)	P. No.	CONNECTORS
<b>Universal V-Throttle cable</b>	Not redundant 5V cable/1 engine	2	42029N	None
		4	42030X	
<b>FPT V-Throttle cable</b>	FPT engines 0 – 5 V cable (J-INV connector)	2	42350S	FPT, all engines with J-INV connector
		4	42351U	
<b>FPT V-Throttle cable</b>	FPT engines 0 – 5 V cable (J-D connector)	2	42348F	FPT, all engines with J-D connector
		4	42349H	
<b>VW V-Throttle cable (4-5-6 cylinder)</b>	VW engines 0 – 5 V cable	2	42033D	VW, 4, 5 and 6 cylinder
		4	42034F	
<b>Mercruiser 4.2 Black V-Throttle cable</b>	Mercruiser engines 0 – 5 V cable	2	42035H	Mercruiser 4.2 black engines
		4	42036K	
<b>Mercruiser QSD V-Throttle cable</b>	Mercruiser engines 0 – 5 V cable	2	42037M	Mercruiser QSD engines
		4	42038P	
<b>Lombardini V-Throttle cable</b>	Lombardini engines 0 – 5 V cable	2	42039S	180 and 240 HP Lombardini engines.
		4	42040A	
<b>Yanmar V-Throttle cable</b>	Yanmar engines 0 – 5 V cable	2	42041C	Yanmar BY engines
		4	42042E	
<b>Universal I/ PWM-Throttle cable</b>	PWM throttle cable with no connector	2	42043G	Compatible with CAT electronic engines C30/C32
		4	42044J	
<b>Universal SAEJ1939-Throttle cable</b>	SAEJ1939 cable with no connector	2	42045L	None
		4	42046N	
<b>NMEA2000 Throttle cable</b>	NMEA2000 cable	1	42047R	DeviceNet cable Drop type for NMEA2000 connection
		3	42048T	
		7	42049V	
<b>Hyundai V-Throttle cable</b>	Hyundai engines 0 – 5 V cable	2	42288P	Hyundai engines
		4	42289S	
<b>Perkins PWM-Throttle cable</b>	Perkins engine PWM Throttle cable	2	42374G	Perkins engines
		4	42373E	

**CHART C - Main system cables**

DESCRIPTION	APPLICATION	LENGTH (m)	P. No.	CONNECTORS
<b>Main power supply cable</b>	Main power supply of the system	1	42052H	One each battery
		3	42053K	
		7	42054M	
		10	42055P	
<b>Power cable extension</b>	Power extension cable for modules connection	1	42056S	One each mechanical actuator or shift unit
		3	42057U	
		7	42058W	
		10	42059Y	
<b>Shift cable</b>	Solenoid connection cable	1	42060G	One each solenoid shift
		3	42061J	
		7	42062L	
		10	42063N	
<b>3 solenoid Shift cable (neutral solenoid)</b>	3 solenoid connection cable	1	42072P	One each 3 solenoid shift
		3	42073S	
		7	42074U	
		10	42075W	
<b>CAN cable</b>	Network connection cable	1	73639T	CAN cable
		3	73680P	
		7	73681S	
		10	71021K	
		15	71031N	
		20	71032R	

**Note:**

Should the engine inverter need the neutral solenoid, the proper shift cable must be used.  
Custom wiring can be done, upon request

**CHART D - Troll cables**

DESCRIPTION	APPLICATION	LENGTH (m)	P. No.	CONNECTORS
<b>Universal V-Troll cable</b>	0-5 V cable with no redundancy	2	42068Z	None
		4	42069B	
<b>Universal I-Troll cable</b>	0.20 mA output cable, no connectors included	2	42070K	None
		4	42071M	

**Spare parts**

MODEL	DESCRIPTION	P. No.	Q.TY
<b>Cable connection kit</b>	Kit to connect the mechanical cable to the actuator	41898N	1 for each actuator
<b>Conduit clamp kit</b>	Conduit clamp kit for mechanical cable	41897L	1 for each actuator

ENGINE	NO. OF ENGINES	COMPONENTS	P. No.	Q.TY
<b>PwA II-EE</b> <b>Electronic throttle</b> <b>Electric shift</b>	<b>Single Engine</b>	Single control with trim (or no trim)	Select control	1
		Control Unit	42017F	1
		E-Throttle unit	Chart A	1
		E-Shift unit	42023A	1
		Throttle cable	Chart B	1
		Shift cable	Chart C	1
		Power supply cable (general)	Chart C	1
		CAN cable	Chart C	3
		Network terminators	42028L	1
	Power Unit (optional for second battery)	42026G	1	
		Power cable extension (optional for second battery)	Chart C	1
		Power supply cable (optional for second battery)	Chart C	1
<b>Two Engines</b>	Dual control with trim (or no trim)	Select control	1	
	Control Unit	42017F	1	
	E-Throttle unit	Chart A	1	
	E-Shift unit	42023A	1	
	Throttle cable	Chart B	2	
	Shift cable	Chart C	2	
	Power supply cable (general)	Chart C	1	
	CAN cable	Chart C	3	
	Network terminators	42028L	1	
Power Unit (optional for second battery)	42026G	1		
	Power cable extension (optional for second battery)	Chart C	1	
	Power supply cable (optional for second battery)	Chart C	1	
<b>PwA II-EM</b> <b>Electronic throttle</b> <b>Mechanical shift</b>	<b>Single Engine</b>	Single control with trim (or no trim)	Select control	1
		Control Unit	42017F	1
		E-Throttle unit	Chart A	1
		Mechanical actuator	42027J	1
		Throttle cable	Chart B	1
		CAN cable	Chart C	3
		Power supply cable (general)	Chart C	1
		Network terminators	42028L	1
		Power Unit (optional for second battery)	42026G	1
	Power cable extension (optional for second battery)		Chart C	1
	Power supply cable (optional for second battery)		Chart C	1
	<b>Two Engines</b>	Dual control with trim (or no trim)	Select control	1
Control Unit		42017F	1	
E-Throttle unit		Chart A	1	
Mechanical actuator		42027J	2	
Throttle cable		Chart B	2	
CAN cable		Chart C	4	
Power supply cable (general)		Chart C	1	
Network terminators		42028L	1	
Power Unit		42026G	1	
Power extension cable	Chart C	2		
Power supply cable (optional for second battery)	Chart C	1		
<b>For each additional station add:</b>				
<b>Single Engine:</b>	Single lever control station with trim (or no trim)	Select control	1	
	CAN cable	Chart C	1	
<b>Two Engines:</b>	Dual lever control station with trim (or no trim)	Select control	1	
	CAN cable	Chart C	1	

ENGINE	NO. OF ENGINES	COMPONENTS	P. No.	Q.TY	
<b>PwA II-ME</b>	<b>Single Engine</b>	Single control with trim (or no trim)	Select control	1	
		Control Unit	42017F	1	
		E-Throttle unit	42023A	1	
		Mechanical actuator	42027J	1	
		Throttle cable	Chart C	1	
		CAN cable	Chart C	3	
		Power supply cable (general)	Chart C	1	
		Network terminators	42028L	1	
		Power Unit (optional for second battery)	42026G	1	
		Power cable extension (optional for second battery)	Chart C	2	
	Power supply cable (optional for second battery)	Chart C	1		
	<b>Mechanical throttle</b>	<b>Two Engines</b>	Dual control with trim (or no trim)	Select control	1
			Control Unit	42017F	1
E-Throttle unit			42023A	1	
Mechanical actuator			42027J	2	
Throttle cable	Chart C		2		
CAN cable	Chart C		4		
Power supply cable (general)	Chart C		1		
Network terminators	42028L		1		
Power Unit	42026G		1		
Power extension cable	Chart C		3		
Power supply cable (optional for second battery)	Chart C		1		
<b>Electronic shift</b>	<b>Single Engine</b>		Single control with trim (or no trim)	Select control	1
			Control Unit	42017F	1
		Mechanical actuator	42027J	2	
		CAN cable	Chart C	3	
		Power supply cable (general)	Chart C	1	
		Network terminators	42028L	1	
		Power Unit	42026G	1	
		Power extension cable	Chart C	2	
		Power supply cable (optional for second battery)	Chart C	1	
		<b>Mechanical throttle</b>	<b>Two Engines</b>	Dual control with trim (or no trim)	Select control
	Control Unit			42017F	1
	Mechanical actuator			42027J	4
	CAN cable			Chart C	5
Power supply cable (general)	Chart C	1			
Network terminators	42028L	1			
Power Unit	42026G	1			
Power extension cable	Chart C	4			
Power supply cable (optional for second battery)	Chart C	1			
<b>Mechanical throttle Mechanical shift</b>	<b>Three Engines</b>	Dual control with trim (or no trim)		Select control	1
		Control Unit		42017F	1
		Control Unit 3/4 engines		43157D	1
		Mechanical actuator		42027J	6
		CAN cable	Chart C	8	
		Power supply cable (general)	Chart C	2	
		Network terminators	42028L	1	
		Power Unit	42026G	2	
		Power extension cable	Chart C	6	
		Power supply cable (optional for second battery)	Chart C	2	
	<b>Mechanical throttle</b>	<b>Four Engines</b>	Dual control with trim (or no trim)	Select control	1
			Control Unit	42017F	1
			Control Unit 3/4 engines	43157D	1
Mechanical actuator			42027J	8	
CAN cable	Chart C		10		
Power supply cable (general)	Chart C		2		
Network terminators	42028L		1		
Power Unit	42026G		2		
Power extension cable	Chart C		8		
Power supply cable (optional for second battery)	Chart C		2		
<b>For each additional station add:</b>					
<b>Single Engine:</b>	Single lever control station with trim (or no trim)		Select control	1	
	CAN cable		Chart C	1	
<b>Two Engines:</b>	Dual lever control station with trim (or no trim)	Select control	1		
	CAN cable	Chart C	1		

**CHART E - Components for Trolling Valve systems\***

ENGINE	NO. OF ENGINES	COMPONENTS	P. No.	Q.TY
<b>Mechanical trolling valve</b>	<b>Single Engine</b>	Mechanical actuator (Troll)	42027J	1
		CAN cable	Chart C	1
		Power cable extension	Chart C	1
<b>Mechanical trolling valve</b>	<b>Twin Engines</b>	Mechanical actuator	42027J	2
		Power Unit	42026G	0 (*)
		CAN cable	Chart C	2
		Power supply cable (general)	Chart C	0 (*)
		Power cable extension	Chart C	2
(*) When there are no more free sockets in the existing power unit, add one Power Unit with one or two power supply cables according to battery number. Refer to the diagram on installation manual.				
<b>Electric troll (proportional solenoid)</b>	<b>Single Engine</b>	Shift Unit	42023A	1(**)
		CAN cable	Chart C	1(**)
		Power cable extension	Chart C	1(**)
		Cavo Shift con Troll	Chart C	1
	<b>Twin Engines</b>	Shift Unit	42023A	1(**)
		CAN cable	Chart C	1(**)
		Power cable extension	Chart C	1(**)
		Power Unit	42026G	0 (*)
		Power supply cable (general)	Chart C	0 (*)
		Shift cable with Troll	Chart C	2
(*) When there are no more free sockets in the existing power unit, add one Power Unit with one or two power supply cables according to battery number. Refer to the diagram on installation manual.				
(**) When a shift unit is already present in the system, it can control the electric troll by using the proper cable. When a shift box is not present, add one to the system with the shift and CAN cables.				
<b>Electronic Troll (0-5V, 4-20mA)</b>	<b>Single Engine</b>	E-Troll Unit	Custom made	1
		CAN cable	Chart C	1
		Troll cable	Chart D	1
	<b>Twin Engines</b>	E-Troll Unit	Custom made	1
		CAN cable	Chart C	1
		Troll cable	Chart D	2

\*Before ordering, please contact our Technical Department





## Ultraflex control boxes



All Ultraflex control boxes are made specifically for the marine environment, using materials and working processes which offer long life and safety for the most extreme conditions

### How control boxes work

A boat's steering system consists of many components, all of which are essential to ensure proper operation and safety in case of emergency manoeuvres.

Among the components used to control the throttle and the boat's direction there are the Ultraflex control boxes.

These are designed to have a correct feeling between the user and the boat.



## Recommendations when choosing a control box

UK  
CA

A correct selection of the control box depends on various factors such as:

- **Communication with engine:** Ultraflex control boxes can be mechanical (when both throttle and shift cable is in use), electronic (when both throttle and shift cable are controlled by a position sensor) and hybrid (when using the throttle position sensor and the inverter cable).
- **Spaces on board:** the control boxes are usually “Top Mount” and “Side Mount”. The “Top Mount” models are installed on the dashboard, the “Side Mount” models on one side of the boat. Attention must be paid to the space around the controls as the rotation of the lever must not be prevented; moreover, in case of mechanical control boxes, it is necessary to ensure the correct routing of the control cables.
- **Design:** Ultraflex control boxes are designed with the aim to follow as much as possible the style of the boat on which they will be installed.

## Warnings

All the control boxes, as they are steering elements, must be kept in perfect condition at all times to ensure their operation. Furthermore, in case of installation with mechanical and hybrid control boxes, the cables and their smoothness inside the conduit must be regularly checked. For a correct maintenance, please refer to the user and maintenance manuals supplied with Ultraflex products.

It is recommended to use in combine with Ultraflex controls a “Universal Emergency Safety Switch”: a safety device to switch the engine off in case of accidental step away of the driver from the driving position.

## Universal Emergency Safety Switch



Emergency Safety Switch - 76691L

- Suitable with most outboard, inboard and sterndrive engines.
- Swivel carabiner eliminates lanyard tangling
- Corrosion resistant
- IP67

# B400

## Single lever side mount controls

Lever	Single lever
Lever control	Dual action control
Assembly	Side mount
Installation	Horizontally or vertically
Applications	Sailing boats, inboard
Version	Fully mechanical
Adjustable friction	Yes
Engine Warm up mode	Yes
X41 Neutral safety switch	included
EN ISO 11547	Yes
Control cables	C2, C8, MachZero

B400	42076Y	B400 Control Box - Fully mechanical version
------	--------	---



B400

Featuring AISI 316 stainless steel lever and bezel, the B400 has a sleek and modern design which is ideal for sailboats. The B400 has an universal control mechanism that allows for both “push” or “pull” for throttle and shift, push button warm up, and will accept 33C style cables without any adapters.

- 316 stainless steel lever and flange for a better resistance in the marine environment
- Enables easy and safe shifting by preventing accidental gear engagement unless engine is idling
- Can be installed horizontally or vertically, on the starboard or port side of the boat
- Provided with a throttle friction system easily adjustable
- Push-in button for throttle operation in Neutral (ENGINE WARM UP).
- Neutral safety switch **X41** – 38130F prevents in-gear starting
- Exceeds EN ISO 11547 standards

### Control cables

- Accept Ultraflex C2, C8, MACHZero control cables (no kit required)

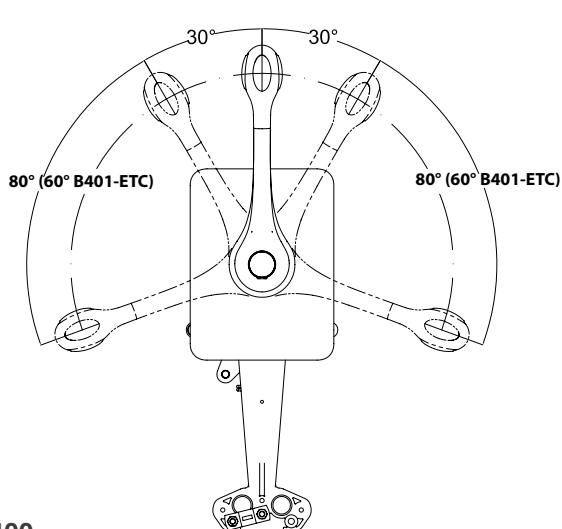

B400

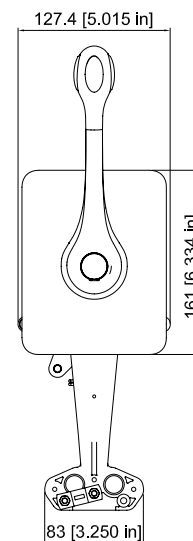
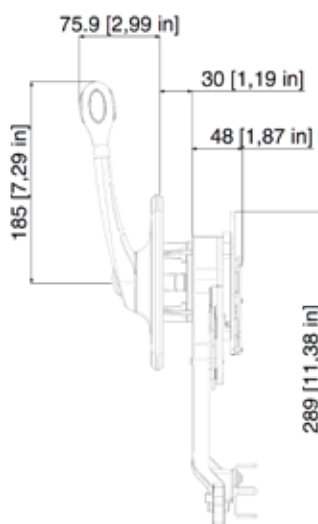

# B401-ETC (Electronic Throttle Control)

## Hybrid single lever side mount control

<b>Lever</b>	Single lever
<b>Lever control</b>	Dual action control
<b>Assembly</b>	Side mount
<b>Installation</b>	Horizontally or vertically
<b>Applications</b>	Sailing boats, inboard
<b>Version</b>	Hybrid mechanical shift electric throttle
<b>Output voltage range</b>	Chosen by the customer between 0 & 5V
<b>Power supply</b>	5V +/-10%, linearity +/-1%
<b>Adjustable friction</b>	Yes
<b>Engine Warm up mode</b>	Yes
<b>X41 Neutral safety switch</b>	Included
<b>EN ISO 11547</b>	Yes
<b>Control cables</b>	C2, C8, MachZero
<b>B401-ETC 42077A</b>	Control Box - Hybrid version (mechanical shift, electronic throttle)



B401-ETC

B401-ETC (Electronic Throttle Control) version is available on request. The sensor has an analog output signal which can be single or redundant. The output voltage range is chosen by the customer between 0 and 5V. Power supply 5V +/-10%, linearity +/-1%.

Featuring AISI 316 stainless steel lever and bezel, the B401-ETC has a sleek and modern design which is ideal for sailboats.

B401-ETC has a universal control mechanism that allows for both "push" or "pull" for throttle and shift, push button warm up, and will accept 33C style cables without any adapters.

- 316 stainless steel lever and flange for a better resistance in the marine environment
- Enables easy and safe shifting by preventing accidental gear engagement unless engine is idling
- Can be installed horizontally or vertically, on the starboard or port side of the boat
- Provided with a throttle friction system easily adjustable
- Push-in button for throttle operation in Neutral (ENGINE WARM UP).
- Neutral safety switch **X41** – 38130F included prevents in-gear starting
- Exceeds EN ISO 11547 standards

### Control cables

- Accept Ultraflex C2, C8, MACHZero control cables (no kit required)

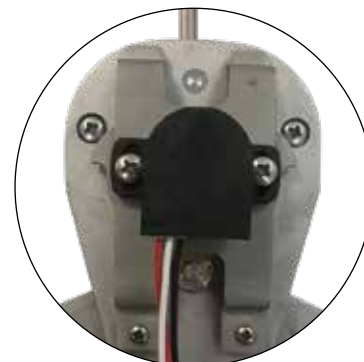
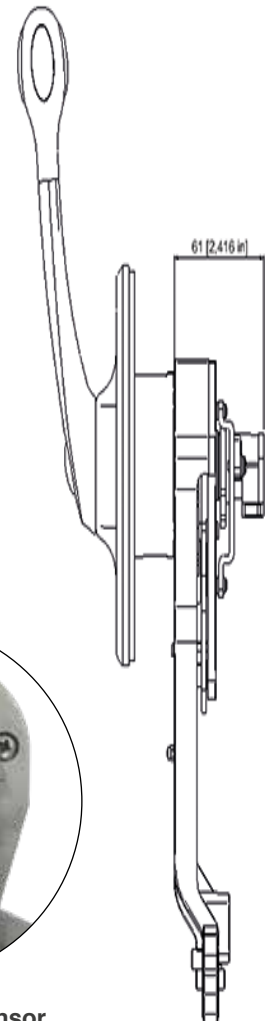

B401-ETC - integrated sensor

B401-ETC

## B310 and B310-ETC series

### Mechanical and hybrid single lever side mount controls



B310CH



B310B



B310BR

Lever	Single lever
Lever control	Dual action control
Assembly	Side mount
Installation	Horizontally or vertically
Applications	Inboard, outboard, sterndrives
Version	Fully mechanical or hybrid (mechanical shift, electronic throttle)
Adjustable friction	Yes
Engine Warm up mode	Yes
X12 Neutral safety switch	included
EN ISO 11547	Yes
Control cables	C2, C8, C14, MachZero, Mach14
Control cables that require a connection kit	C5, C16, Mach5 (K35); C22 (KB1)

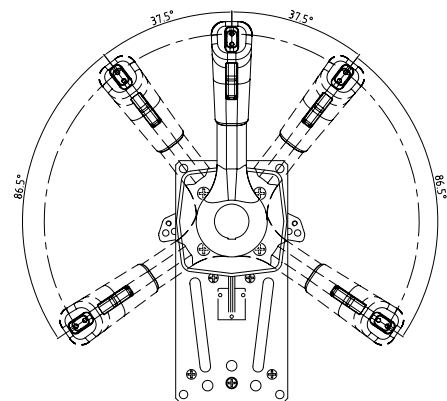

The B310 controls combine elegance, functionality and versatility.

Available with chrome plated, burl or soft touch control levers, the B310 series can be used on outboards, sterndrives and inboard applications.

The universal control design allows for the connection of 33C Universal style cable and OMC (Johnson/Evinrude) cables with adapters included.

Mercury Gen I cables can be easily connected with the addition of the K35 connection kit

- Enables easy and safe shifting by preventing accidental gear engagement unless engine is idling
- Can be installed horizontally or vertically, on the starboard or port side of the boat
- Provided with a throttle friction system adjustable from outside
- Pull-out handle disengages shift for warm-up
- Neutral safety switch **X12** – 34543Q prevents in-gear starting
- Exceeds EN ISO 11547 standards
- All models are provided with positive lock-in neutral to prevent accidental gear engagement
- All models are provided with a power trim switch conveniently located in the handle grip that enables an easy tilting of the engine

#### Control cables

For use with:

- All Ultraflex control cables except C36 and MACH36
- Ultraflex C5, C16, MACH5 and Mercury® cables require K35 – 34730U connection kit
- Ultraflex C22 cables require KB1 – 39964L connection kit

## B310 and B310-ETC series Mechanical and hybrid single lever side mount controls



**B310B-ETC**



**B310B-NT No Trim**

B310B-ETC (Electronic Throttle Control) version is available on request. The sensor has an analog output signal which can be single or redundant.

The output voltage range is chosen by the customer between 0 and 5V. Power supply 5V +/-10%, linearity +/-1%.

<b>B310CH</b>	41789H	Chrome plated version, provided with a positive lock-in neutral and trim switch
<b>B310BR</b>	41788F	Burl version, provided with a positive lock-in neutral and trim switch
<b>B310B</b>	41790S	Black version, provided with a positive lock-in neutral and trim switch
<b>B310B-NT</b>	42628M	Black version, Provided with a positive lock-in neutral and without trim switch
<b>B310B-ETC</b>	44041N	Hybrid version (mechanical shift, electronic throttle)

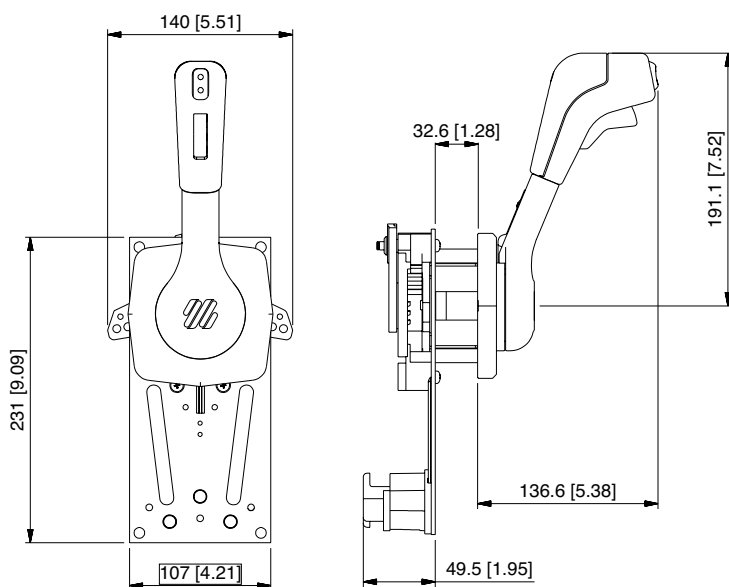

**B310CH - B310BR - B310B - B310B-ETC**



## B183 - B184 - B85 - B183-ETC - B184-ETC - B85-ETC

### Mechanical or hybrid single lever side mount controls



**B183**  
**B183-ETC**



**B184 - with Trim**  
**B184-ETC**



Mechanical or hybrid single lever / dual action control to operate both throttle and shift.  
Suitable for any type of boat with outboard engine

- Enables easy and safe shifting by preventing accidental gear engagement unless engine is idling
- Can be installed horizontally or vertically, on the starboard or port side of the boat
- Provided with a throttle friction system adjustable from outside
- Pull-out handle disengages shift for warm-up
- Neutral safety switch **X12** – 34543Q prevents in-gear starting.
- Exceeds EN ISO 11547 standards
- Provided with positive lock-in neutral to prevent accidental gear engagement

**B184** model is provided with a **power trim switch** conveniently located in the handle grip that enables an easy tilting of the engine

**B85** model has a smooth design for use on sailboats.

	<b>B183</b>	<b>B184</b>	<b>B85</b>
<b>Lever</b>	Single lever	Single lever	Single lever
<b>Lever control</b>	Dual action control	Dual action control	Dual action control
<b>Assembly</b>	Side mount	Side mount	Side mount
<b>Installation</b>	Horizontally or vertically	Horizontally or vertically	Horizontally or vertically
<b>Applications</b>	Inboard	Inboard, outboard, sterndrives	Inboard, sailboats
<b>Version</b>	Fully mechanical or hybrid	Fully mechanical or hybrid	Fully mechanical or hybrid
<b>Adjustable friction</b>	Yes	Yes	Yes
<b>Warm-up mode</b>	Yes	Yes	Yes
<b>Positive lock-in neutral</b>	Yes	Yes	Yes
<b>Power trim switch</b>	No	Yes	No
<b>X12 Neutral Safety Switch</b>	Included	Included	Included
<b>EN ISO 11547</b>	Yes	Yes	Yes
<b>Control cables</b>	C2, C8, MachZero, Mach14	C2, C8, MachZero, Mach14	C2, C8, MachZero, Mach14
<b>Control cables that require a connection kit</b>	C5, C16, Mach5 (K35)	C5, C16, Mach5 (K35)	C5, C16, Mach5 (K35)

# B183 - B184 - B85 - B183-ETC - B184-ETC - B85-ETC

## Mechanical or hybrid single lever side mount controls



**B85  
B85-ETC**

<b>B183</b>	38945B	Provided with a positive lock-in neutral
<b>B184</b>	38946D	Provided with a positive lock-in neutral and trim switch
<b>B85</b>	35682I	Provided with a positive lock-in neutral

B183, B184, B85 are available also in the hybrid version (mechanical shift and electronic throttle)

<b>B183-ETC</b>	44020E	Provided with a positive lock-in neutral
<b>B184-ETC</b>	43983P	Provided with a positive lock-in neutral and trim switch
<b>B85-ETC</b>	44040L	Provided with a positive lock-in neutral

B183-ETC - B184-ETC - B85-ETC (Electronic Throttle Control) version are available on request.

The sensor has an analog output signal which can be single or redundant. The output voltage range is chosen by the customer between 0 and 5V. Power supply 5V +/-10%, linearity +/-1%.

**Control cables:**

- For use with all Ultraflex engine control cables except C22, C36 and MACH36.
- Ultraflex C5, C16 and MACH5 cables require K35 – 34730U connection kit
- Ultraflex C22 cable requires KB1 – 39964L connection kit

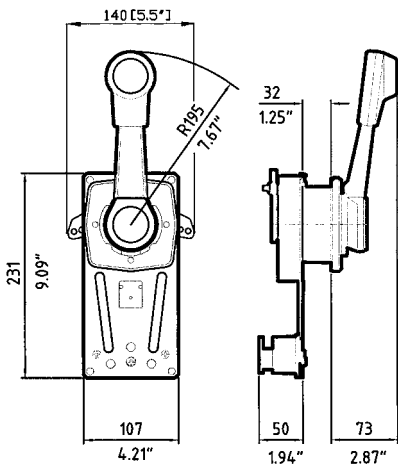

**B85 - B85-ETC**

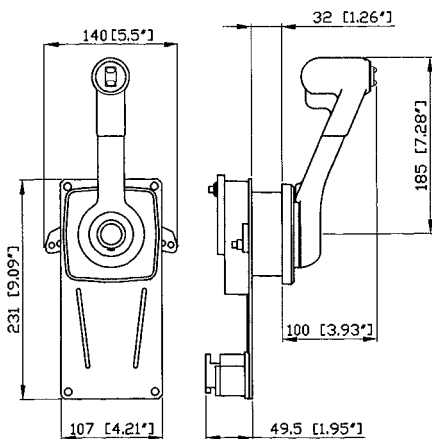

**B183 - B183-ETC B184 - B184-ETC**

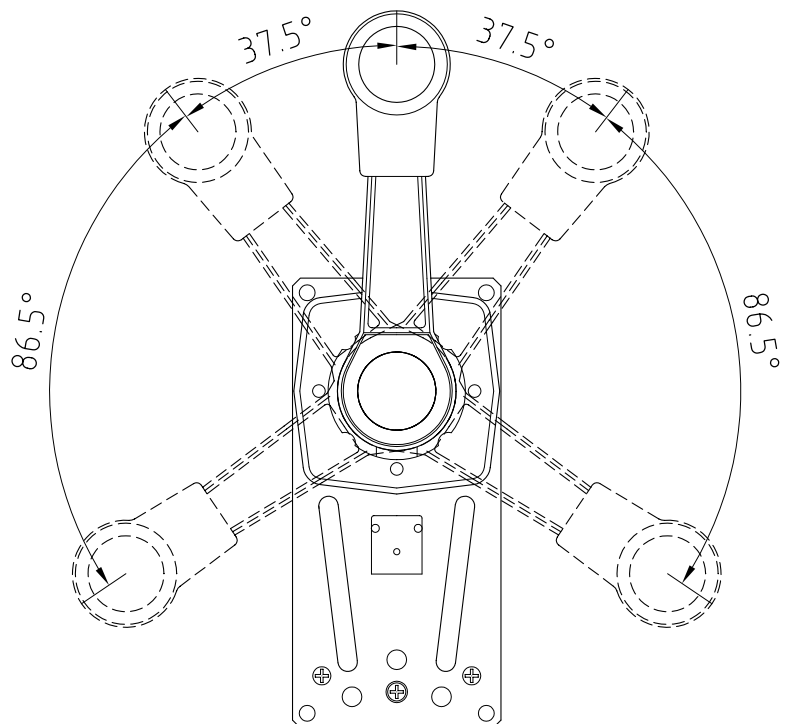

## B120 - B120/KS

### Single lever side mount controls

**new**



**B120B**



**B120W**

CE UK  
CA

Single lever / dual action control to operate both throttle and shift.  
Suitable for any type of boat with outboard or sterndrive engines.

- Enables easy and safe shifting by preventing accidental gear engagement unless engine is idling
- Provided with a throttle friction system adjustable from outside
- Push-in button for throttle operation in neutral (engine warm-up)
- Provided with positive lock-in neutral to prevent accidental gear engagement
- X41 (with IP67 Protection) and X48 optional neutral safety switches available to prevent in-gear starting
- Exceeds EN ISO 11547 standards when X41 and X48 safety switch is installed

<b>B120B</b>	44121L	Black, with trim, with no emergency safety switch
<b>B120W</b>	44123R	White, with trim, with no emergency safety switch
<b>B120B/KS</b>	44122N	Black, with trim, with emergency safety switch
<b>B120W/KS</b>	44124T	White, with trim, with emergency safety switch

<b>Lever</b>	Single lever
<b>Lever control</b>	Dual action control
<b>Assembly</b>	Side mount
<b>Applications</b>	Outboard, sterndrives
<b>Version</b>	Fully mechanical
<b>Adjustable friction</b>	Yes
<b>Engine warm up mode</b>	Yes
<b>Positive lock in neutral</b>	Yes
<b>Power trim switch</b>	Yes
<b>Emergency Safety Switch</b>	Provided on the KS version
<b>Lever Stroke</b>	+/- 110°
<b>X41 Neutral Safety Switch - with IP67 Protection</b>	Not included - to be ordered separately
<b>X48 Neutral Safety Switch</b>	Not included - to be ordered separately
<b>EN ISO 11547</b>	Yes, when X41 or X48 safety switch are installed
<b>Control cables</b>	C2, C8, MachZero
<b>Control cables that require a connection kit</b>	C5, Mach5 (K74); C36, Mach36 (K75); C14, Mach14 (K76);

# B120 - B120/KS

## Single lever side mount controls

CE UK  
CA

new



B120B/KS



B120W/KS

### Control cables

- For use with Ultraflex C2, C8 and MachZero control cables
- Ultraflex C5 and Mach5 cables require the K74 - 44170A connection kit
- Ultraflex C36 and Mach36 cables require the K75 - 44171C connection kit
- Ultraflex C14 and Mach14 cables require the K76 - 44172E connection kit

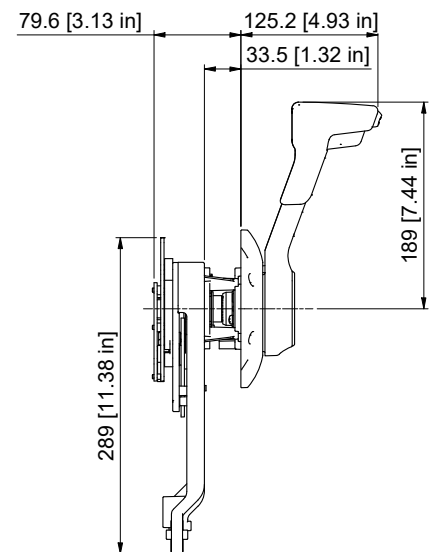
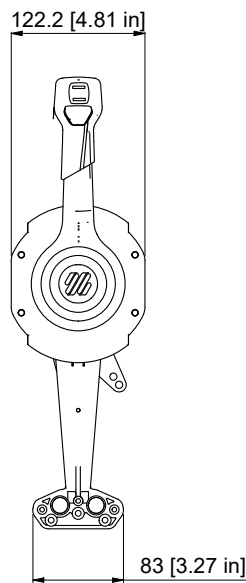
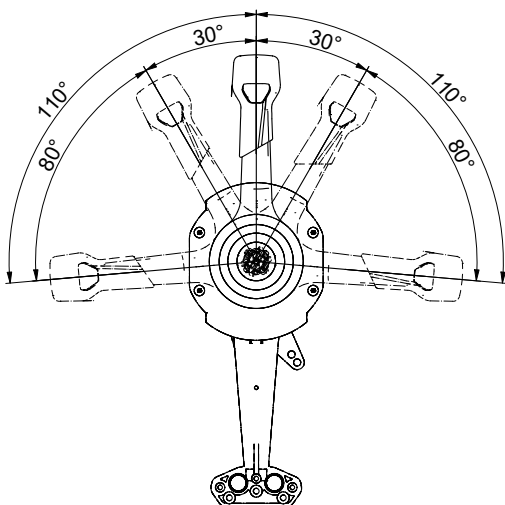

B120

## B110 - B110/KS

### Single lever console mount controls



**B110B**



**B110W**



Single lever / dual action control to operate both throttle and shift.  
Suitable for any type of boat with outboard engine or sterndrive units.

- Enables easy and safe shifting by preventing accidental gear engagement unless engine is idling
- Provided with an easy adjustable brake tension release system
- Push-in button for throttle operation in neutral (engine warm-up)
- Lock in neutral trigger to prevent accidental engaging
- **X41** (with IP67 Protection) and **X48** neutral safety switches to prevent in-gear starting
- Exceeds EN ISO 11547 standards
- Center console trim switch thumb operated

<b>B110B</b>	39367S	Black, with trim, with no kill switch
<b>B110W</b>	43521Y	White, with trim, with no kill switch
<b>B110B/KS</b>	43522A	Black, with trim, with kill switch
<b>B110W/KS</b>	43523C	White, with trim, with kill switch

<b>Lever</b>	Single lever
<b>Lever control</b>	Dual action control
<b>Assembly</b>	Side mount
<b>Applications</b>	Inboard, outboard, sterndrives
<b>Version</b>	Fully mechanical
<b>Adjustable friction</b>	Yes
<b>Engine warm up mode</b>	Yes
<b>lock-in trigger</b>	Yes
<b>Power trim switch</b>	Yes
<b>Emergency Safety Switch</b>	Provided on the KS version
<b>Lever Stroke</b>	+/- 110°
<b>X41 Neutral Safety Switch - with IP67 Protection</b>	Included
<b>X48 Neutral Safety Switch</b>	Included
<b>EN ISO 11547</b>	Yes
<b>Control cables</b>	C2, C8, MachZero
<b>Control cables that require a connection kit</b>	C5, Mach5 (K74); C36, Mach36 (K75); C14, Mach14 (K76);

# B110 - B110/KS

## Single lever console mount controls



B110B/KS



B110W/KS

**Control cables**

- For use with Uflex C2, C8 and MachZero control cables
- Uflex C5 and Mach5 cables require the K74 connection kit
- Uflex C36 and Mach36 cables require the K75 connection kit
- Uflex C14 and Mach14 cables require the K76 connection kit

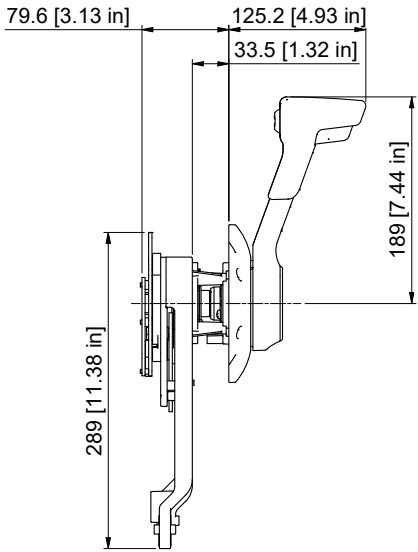
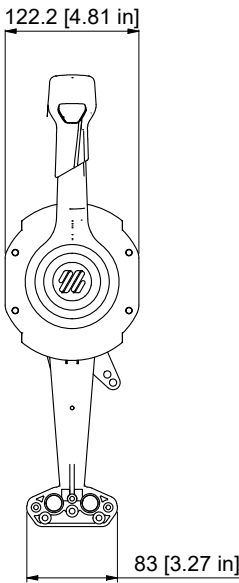
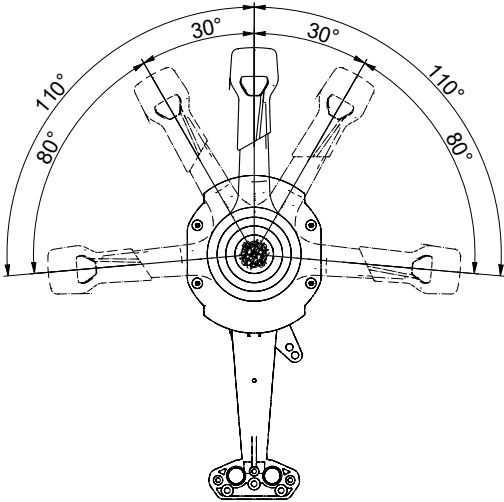

B110



## B110 ETC (Electronic Throttle Control) Hybrid single console side mount controls



**B110B-ETC**



**B110W-ETC**



B110 ETC (Electronic Throttle Control) is a Single lever / dual action control to operate both throttle and shift and is a version of the B110 Control box Available on request.

The sensor has an analog output signal which can be single or redundant.

The output voltage range is chosen by the customer between 0 and 5V. Power supply 5V +/-10%, linearity +/-1%.

For ETC controls please contact our technical Service for Custom Configuration.

<b>Lever</b>	Single lever
<b>Lever control</b>	Dual action control
<b>Assembly</b>	Side mount
<b>Applications</b>	Inboard, outboard, sterndrives
<b>Version</b>	Hybrid - mechanical shift, electric throttle
<b>Electronic Throttle Control</b>	Yes
<b>Output voltage range</b>	Chosen by the customer between 0 & 5V
<b>Power supply</b>	5V +/-10%, linearity +/-1%
<b>Adjustable friction</b>	Yes
<b>Engine warm up mode</b>	Yes
<b>lock-in trigger</b>	Yes
<b>Power trim switch</b>	Yes
<b>Emergency Safety Switch</b>	Provided on the KS version
<b>Lever Stroke</b>	+/- 110°
<b>X41 Neutral Safety Switch - with IP67 Protection</b>	Included
<b>X48 Neutral Safety Switch</b>	Included
<b>EN ISO 11547</b>	Yes
<b>Control cables</b>	C2, C8, MachZero
<b>Control cables that require a connection kit</b>	C5, Mach5 (K74); C36, Mach36 (K75); C14, Mach14 (K76);

<b>B110B-ETC</b>	43751S	Black, with trim, with no kill switch
<b>B110W-ETC</b>	43750P	White with trim, with no kill switch
<b>B110B/KS-ETC</b>	43749F	Black, with trim, with kill switch
<b>B110W/KS-ETC</b>	43748D	White, with trim, with kill switch



**B110B/KS-ETC**



**B110W/KS-ETC**

# B110 ETC (Electronic Throttle Control) Hybrid single lever console mount controls



## B110B-ETC B110W-ETC

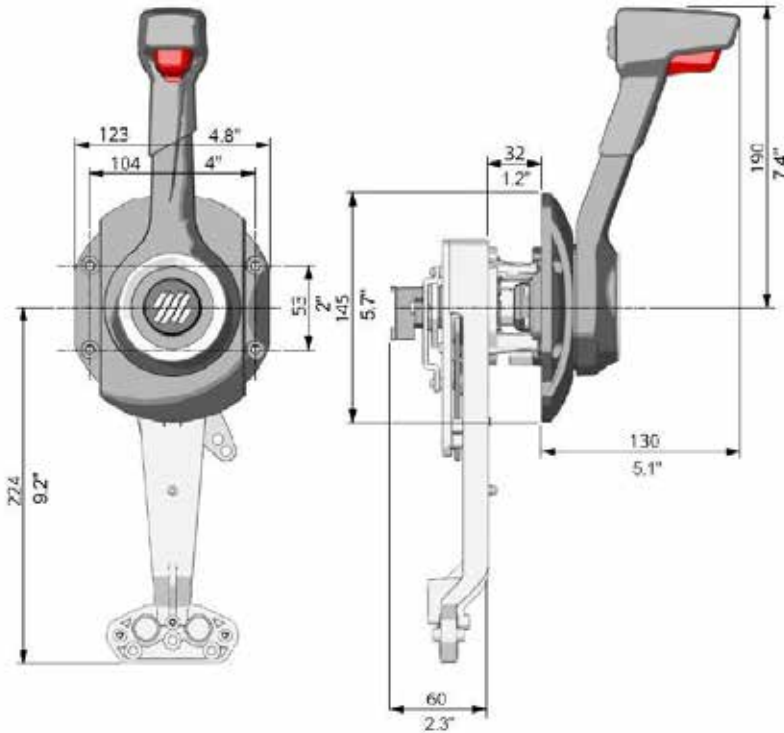

Suitable for any type of boat with outboard engine, inboard or sterndrive units.

- Enables easy and safe shifting by preventing accidental gear engagement unless engine is idling
- Provided with an easy adjustable brake tension release system
- Push-in button for throttle operation in neutral (engine warm-up)
- Lock in neutral trigger to prevent accidental engaging
- X41 (IP67 Protection) 38130F and X48 43527L safety switches to prevent in-gear starting
- Exceeds EN ISO 11547 standards when X41 safety switch is installed
- Center console trim switch thumb operated

### Control cables

- For use with Uflex C2, C8 and MachZero control cables
- Uflex C5 and Mach5 cables require the K74 connection kit
- Uflex C36 and Mach36 cables require the K75 connection kit
- Uflex C14 and Mach14 cables require the K76 connection kit

## B110B/KS-ETC B110W/KS-ETC

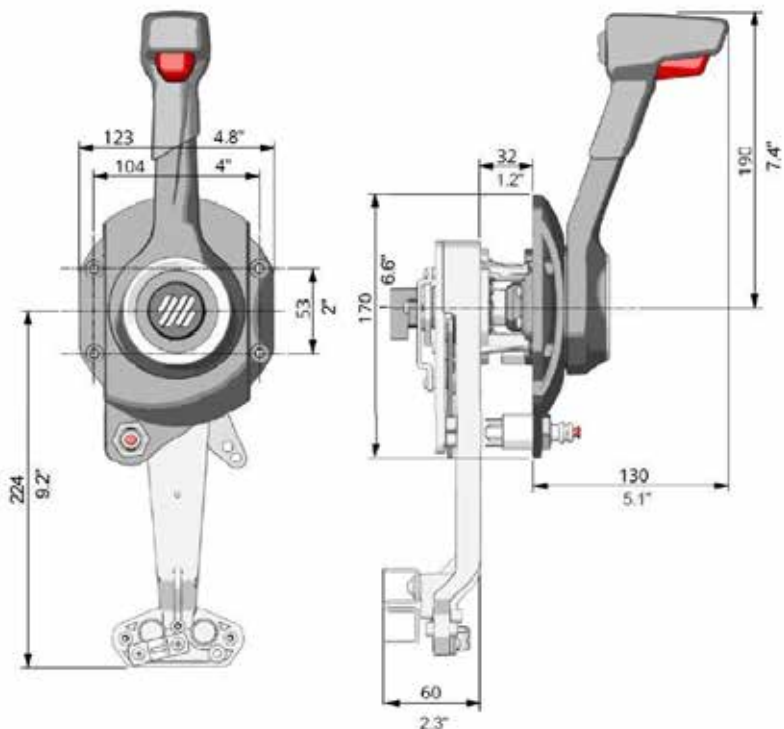

## B89 -B90

### Single lever side mount controls



B90



B89



Single lever / dual action control to operate both throttle and shift.  
Suitable for any type of boats with outboard, inboard or I/O power plants.

- Enables easy and safe shifting by preventing accidental gear engagement unless engine is idling
- Can be installed horizontally or vertically, on the starboard or port side of the boat
- Made of painted marine aluminum
- Pull-out handle disengages shift for warm-up
- Includes X12 neutral safety switch which prevents in-gear starting
- Exceeds EN ISO 11547 standards
- Provided with a positive lock-in neutral to prevent accidental gear engagement

#### Control cables

- For use with all Uflex engine control cables except C22, C36 and MACH36.
- Uflex C5, C16 and MACH5 cables require K35 – 34730U connection kit.
- To connect C14 and MACH14 cables to engine, use K51 – 32526N connection kit.

<b>Lever</b>	Single lever
<b>Lever control</b>	Dual action control
<b>Assembly</b>	Side mount
<b>Applications</b>	Inboard
<b>Material</b>	Painted marine aluminum
<b>Version</b>	Fully mechanical
<b>Adjustable friction</b>	No
<b>Warm-up mode</b>	Yes
<b>Positive lock-in neutral</b>	Yes
<b>Power trim switch</b>	No
<b>Lever Stroke</b>	+/- 95°
<b>X12 Neutral Safety Switch</b>	Included
<b>EN ISO 11547</b>	Yes
<b>Control cables</b>	C2, C8, MachZero
<b>Control cables that require a connection kit</b>	C5, C16, Mach5 (K35); C14, Mach14 (K51);

<b>B89</b>	36151G	Ivory finish with positive lock-in neutral.
<b>B90</b>	36152H	Black finish with positive lock-in neutral.

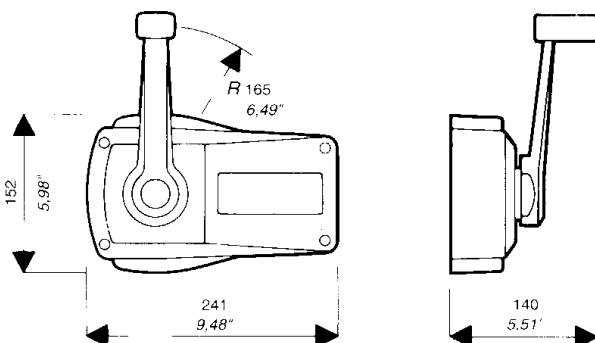

Lock-in neutral



**B501BCT**



**B502BCT**



**B501BT/L**



**B502BT**

Single-lever dual-action control units for throttle and inverter control. Available with and without lock in neutral and with and without trim.

- They make control safer by preventing the inverter from engaging if the throttle is not idling
- Two versions available:
  - Black composite housing and chrome plated levers
  - Painted control boxes with gunmetal-colored die-cast levers
- Pressing a button disengages the inverter during engine warm-up operation
- By means of safety switch X12 - 34543Q (optional), engine starting is achieved only with the inverter in neutral position
- The trim located on the lever operates the 2 engines simultaneously, while the switch trims located on the binnacle allow independent adjustment of the engines
- Compliant with EN ISO 11547 with X12 neutral safety switch

#### **Control cables**

For use with all Ultraflex control cables

- C14 and MACH14 cables require no kit
- For C2, C8 and MACHZero cables the connection kit K59 – 40144C is included
- C5, C16 and MACH5 cables require K60 Kit – 40145E
- C36 and MACH36 cables require K62 Kit – 40147J
- C22 cable requires K61 Kit – 40146G

## B501 - B502 series Top mount controls

### Controls with lock in neutral

<b>B501BCT/L</b>	44146D	Single engine, with lock and trim black composite and chrome plated levers
<b>B502BCT/L</b>	44147F	Double engine, with lock and trim black composite and chrome plated levers
<b>B501BT/L</b>	43036R	Single engine, with lock and trim - Gun metal
<b>B502BT/L</b>	43259M	Double engine, with lock and trim - Gun metal



	B501-B502	B501-B502 with trim	B501-B502 with trim and lock in neutral
<b>Lever</b>	Single lever/Twin lever for 2 engines	Single lever/Twin lever for 2 engines	Single lever/Twin lever for 2 engines
<b>Level control</b>	Dual action control	Dual action control	Dual action control
<b>Assembly</b>	Top mount	Top mount	Top mount
<b>Housing Material</b>	High resistance ABS	High resistance ABS	High resistance ABS
<b>Applications</b>	Inboard	Inboard, outboard & sterndrive	Inboard, outboard & sterndrive
<b>Version</b>	Fully mechanical	Fully mechanical	Fully mechanical
<b>Adjustable friction</b>	Yes	Yes	Yes
<b>Warm-up mode</b>	Yes	Yes	Yes
<b>Positive lock-in neutral</b>	No	No	Yes
<b>Power trim switch</b>	No	Yes	Yes
<b>X12 Neutral Safety Switch</b>	Included	Included	Included
<b>EN ISO 11547</b>	Yes	Yes	Yes
<b>Control cables</b>	C14, Mach14	C14, Mach14	C14, Mach14
<b>Control cables that require a connection kit</b>	C2, C8, MachZero (K59 incluso); C5, C16, Mach5 (K60); C36, Mach36 (K62); C22 (K61)	C2, C8, MachZero (K59 incluso); C5, C16, Mach5 (K60); C36, Mach36 (K62); C22 (K61)	C2, C8, MachZero (K59 incluso); C5, C16, Mach5 (K60); C36, Mach36 (K62); C22 (K61)

## B501 - B502 series Top mount controls

<b>B501BC</b>	44148H	Single engine, no trim - black composite and chrome plated levers
<b>B501BCT</b>	44199K	Single engine, with trim - black composite and chrome plated levers
<b>B502BC</b>	44150U	Double engine, no trim - black composite and chrome plated levers
<b>B502BCT</b>	44151W	Double engine, with trim - black composite and chrome plated levers

<b>B501B</b>	43031E	Single engine, no trim - Gun metal
<b>B501BT</b>	43032G	Single engine, with trim - Gun metal
<b>B502B</b>	43033J	Double engine, no trim - Gun metal
<b>B502BT</b>	43257H	Double engine, with trim - Gun metal

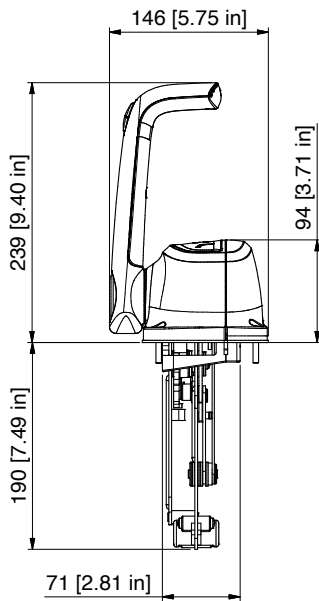

**B501 - B502 Dimensions**

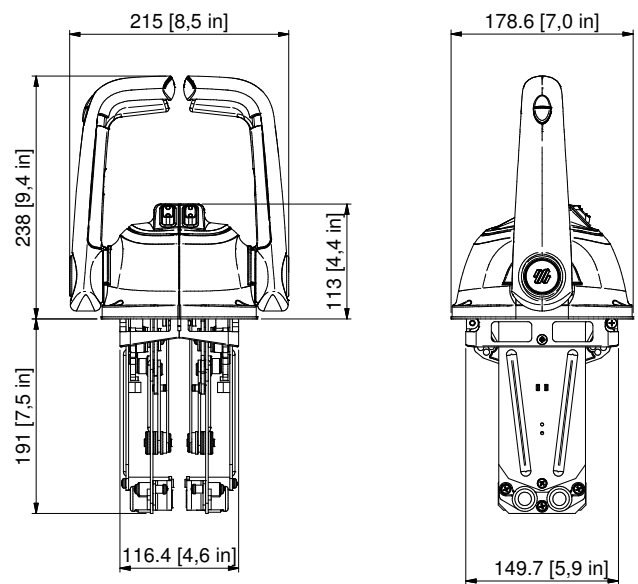

**B502BCT/L - B502BT/L Dimensions**



# B65 - B76 - B73 - B77

## Single lever top mount controls



**B65**  
B76 with trim



**B73**  
B77 with trim

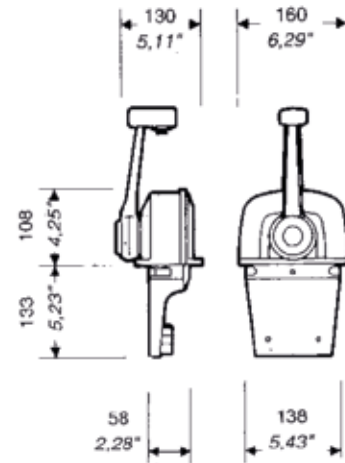

Single lever / dual action control to operate both throttle and shift.

Suitable for any type of boats with inboard (B65 e B73) outboard or I/O power plants (B76 e B77, Trim version)

- Enables easy and safe shifting by preventing accidental gear engagement unless engine is idling
- Made of marine aluminum, chrome plated or with a black powder coat finish
- Pull-out handle disengages shift for engine warm-up
- Neutral safety switch X12 – 34543Q prevents in-gear starting
- Exceeds EN ISO 11547 standards
- **B76 and B77** models have a power Trim switch conveniently located in the handle grip that enables for easy tilting of the engine.

### Control cables

- For use with all Ultraflex engine control cables except C22, C36 and MACH36.
- Ultraflex C5, C16 and MACH5 cables require K35 kit – 34730U

<b>Lever</b>	Single lever
<b>Lever control</b>	Single lever
<b>Assembly</b>	Top mount
<b>Applications</b>	Inboard (B65, B73), outboard & sterndrive (B76, B77)
<b>Version</b>	Fully mechanical
<b>Material</b>	Marine aluminum
<b>Adjustable friction</b>	No
<b>Warm up mode</b>	Yes
<b>Positive lock-in neutral</b>	No
<b>Power trim switch</b>	Provided on the B76, B77 versions
<b>X12 Neutral Safety Switch</b>	Included
<b>EN ISO 11547</b>	Yes
<b>Control cables</b>	C2, C8, MachZero, C14, Mach14
<b>Control cables that require a connection kit</b>	C5, C16, Mach5 (K35)

<b>B65</b>	34731V	Chromed Single lever control for one engine.
<b>B76</b>	35312E	Chromed Single lever control for one engine, with trim.
<b>B73</b>	35007U	Single lever control for one engine, Black Powder coat finish
<b>B77</b>	35313F	Single lever control for one engine, Black Powder coat finish, with trim



**Handle with trim**

## B66 - B78 - B74 - B79 Single lever top mount controls

B66  
B78 with trim



B74  
B79 with trim

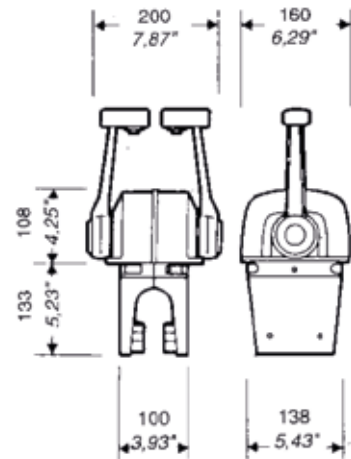

Twin lever control for 2 engines

Dual action control to operate both throttle and shift.

Suitable for any type of boats with inboard (B66 e B74) outboard or I/O power plants (B78 e B79, Trim version)

- Enables easy and safe shifting by preventing accidental gear engagement unless engine is idling
- Made of marine aluminum, chrome plated or with a black powder coat finish
- Pull-out handle disengages shift for engine warm-up
- Neutral safety switch **X12** – 34543Q prevents in-gear starting
- Exceeds EN ISO 11547 standards
- **B78 and B79** models have a power Trim switch conveniently located in the handle grip that enables for easy tilting of the engine.

### Control cables

- For use with all Ultraflex engine control cables except C22, C36 and MACH36.
- Ultraflex C5, C16 and MACH5 cables require K35 kit – 34730U

<b>Lever</b>	Twin lever for 2 engines
<b>Level control</b>	Dual action control
<b>Assembly</b>	Top mount
<b>Applications</b>	Inboard (B66, B74), outboard & sterndrive (B78, B79)
<b>Version</b>	Fully mechanical
<b>Materials</b>	Marine aluminum
<b>Adjustable friction</b>	No
<b>Warm up mode</b>	Yes
<b>Positive lock-in neutral</b>	No
<b>Power trim switch</b>	Provided on the B78, B79 versions
<b>X12 Neutral Safety Switch</b>	Included
<b>EN ISO 11547</b>	Yes
<b>Control cables</b>	C2, C8, MachZero, C14, Mach14
<b>Control cables that require a connection kit</b>	C5, C16, Mach5 (K35)

<b>B66</b>	34732W	Chromed twin lever control for two engines.
<b>B78</b>	35314G	Chromed twin lever control for two engines, with trim
<b>B74</b>	35008B	Twin lever control for two engines, Black Powder coat finish
<b>B79</b>	35315H	Twin lever control for two engines, Black Powder coat finish, with Trim



Handle with trim

## B301 - B302

### “Low profile” single lever top mount controls

Compact single lever controls offering a unique low profile style compared to other controls available on the market. Single lever / dual action control to operate both throttle and shift.

Suitable for any type of boat with inboard engine

- Enables easy and safe shifting by preventing accidental gear engagement unless engine is idling
- Made of marine aluminum, chrome plated or powder coat finish
- Push in button disengages shift for warm-up
- Includes **X12** neutral safety switch which prevents in-gear starting
- Exceeds EN ISO 11547 standards

#### Control cables

- For use with all Uflex control cables except C4:
  - C14 and MACH14 cables require no kit
  - for C2, C8 and MACHZero cables the connection kit **K59** - 40144C is included
  - C5, C16 and MACH5 cables require **K60** Kit - 40145 E
  - C36 and MACH6 cables require **K62** Kit - 40157J
  - C22 cable requires **K61** Kit - 40146G



B301CR



B302CR



2 X75 Optional



B302CR + 2 X75

B301CR	40140U	Single lever for one engine
B302CR	40141W	Twin lever for two engines
X75	40662B	Silver knob optional

Lever	Single lever
Lever control	Dual action control
Assembly	Top mount
Applications	Inboard
Version	Fully mechanical
Material	Chromed marine aluminum
Adjustable friction	Yes
Warm up mode	Yes
Positive lock-in neutral	No
Power trim switch	No
X12 Neutral Safety Switch	Included
EN ISO 11547	Yes
Control cables	C14, Mach14
Control cables that require a connection kit	C2, C8, MachZero (K59 inclusio); C5, C16, Mach5 (K60); C36, Mach36 (K62); C22 (K61);

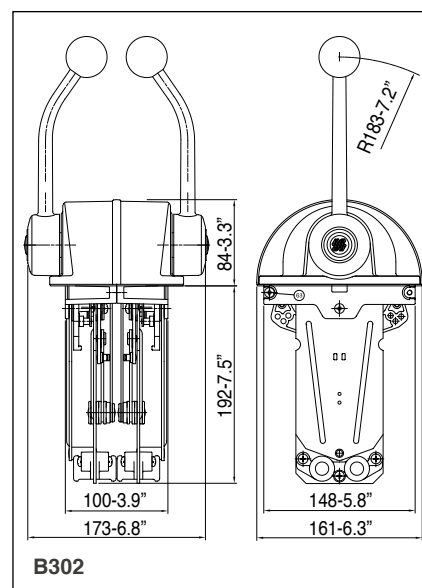
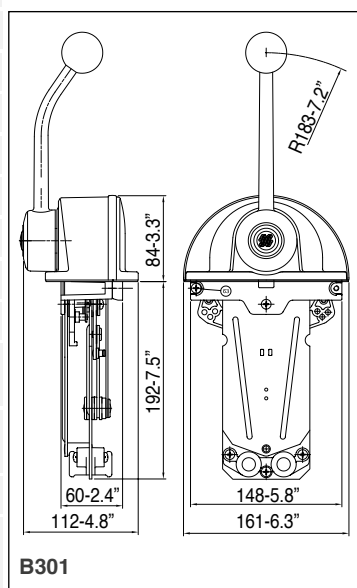

# B301 - B302

## “Low profile” single lever top mount controls

Compact single lever controls offering a unique low profile style compared to other controls available on the market  
Single lever / dual action control to operate both throttle and shift.

Suitable for any type of boat with inboard engine

- Enables easy and safe shifting by preventing accidental gear engagement unless engine is idling
- Made of marine aluminum, chrome plated or powder coat finish
- Push in button disengages shift for warm-up
- Includes **X12** neutral safety switch which prevents in-gear starting
- Exceeds EN ISO 11547 standards

### Control cables

- For use with all Uflex control cables except C4:
  - C14 and MACH14 cables require no kit
  - for C2, C8 and MACHZero cables the connection kit is **K59** - 40144 C included
  - C5, C16 and MACH5 cables require **K60** Kit - 40145 E
  - C36 and MACH36 cables require **K62** Kit - 40157 J
  - C22 cable requires **K61** Kit - 40146G



B301B



B302B



2 X75 Optional



B302B + 2 X75

<b>B301B</b>	40142Y	Single lever for one engine
<b>B302B</b>	40143A	Twin lever for two engines
<b>X75</b>	40662B	Silver knob optional

<b>Lever</b>	Single lever
<b>Lever control</b>	Dual action control
<b>Assembly</b>	Top mount
<b>Applications</b>	Inboard
<b>Version</b>	Fully mechanical
<b>Material</b>	Black marine aluminum
<b>Adjustable friction</b>	Yes
<b>Warm up mode</b>	Yes
<b>Positive lock-in neutral</b>	No
<b>Power trim switch</b>	No
<b>X12 Neutral Safety Switch</b>	Included
<b>EN ISO 11547</b>	Yes
<b>Control cables</b>	C14, Mach14
<b>Control cables that require a connection kit</b>	C2, C8, MachZero (K59 inclusio); C5, C16, Mach5 (K60); C36, Mach36 (K62); C22 (K61);

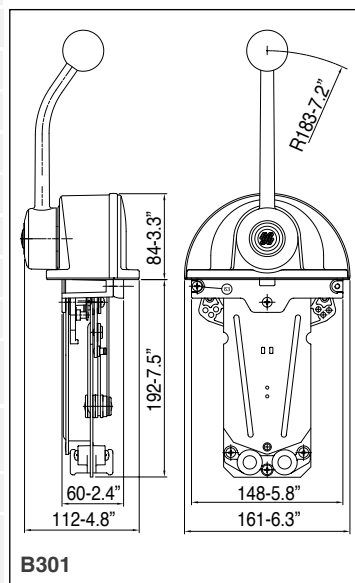

B301

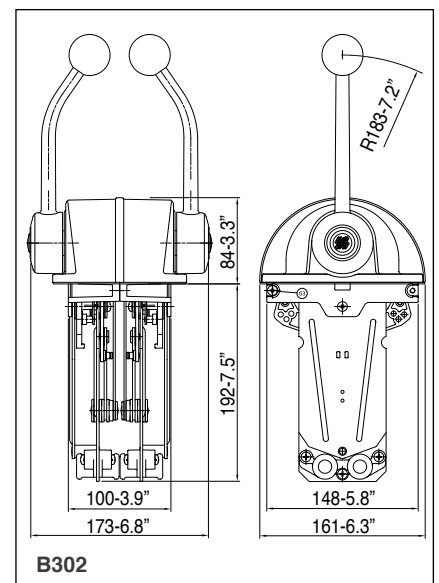

B302

# B103 - B104

## Single lever top mount controls

Single lever / dual action control to operate both throttle and shift.  
Suitable for any type of boat with inboard engine



- Enables easy and safe shifting by preventing accidental gear engagement unless engine is idling
- Made of chrome plated marine aluminum
- Pull-out handle disengages shift for warm-up
- Neutral safety switch **X43** – 38160L prevents in-gear starting
- Exceeds EN ISO 11547 standards

### Control cables

- For use with C2, C8 and MACHZero Ultraflex engine control cables
- Only for B103, To connect C22 cable use **K33** – 38378D connection kit



B103



B104



B104+ 2 X55

B103	37923K	Single lever control for one engine
B104	37924L	Twin lever control for two engines
X55	39421V	Silver knob Optional

Lever	Single lever
Lever control	Dual action control
Assembly	Top mount
Applications	Inboard
Version	Fully mechanical
Material	Marine aluminum
Warm up mode	Yes
Positive lock-in neutral	No
Power trim switch	No
X43 Neutral Safety Switch	Included
EN ISO 11547	Yes
Control cables	C2, C8, MachZero
Control cables that require a connection kit	B103 - C22 (K33)

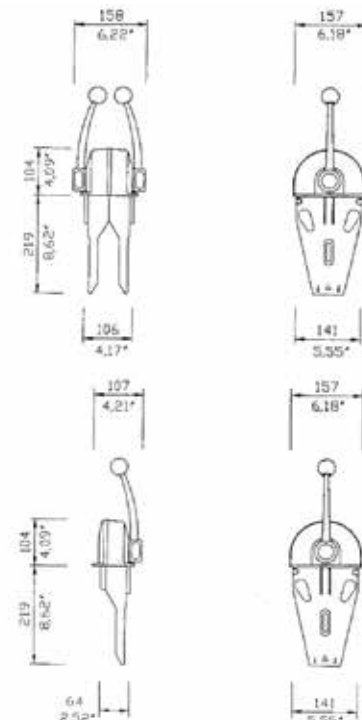



# B505-ESTC (Electronic Shift Throttle Control) Electric single lever top mount control

Ergonomic and compact single lever control, designed to control outboards and sterndrive electric engines.

B505-ESTC is **customizable**:

- Sensor output
- Lever switch (Trim - standard - or lock-in trigger)
- Switches

- Compact single lever controls offering a unique low profile style compared to other controls available on the market
- Equipped with adjustable clutch to set the throttle hardness.
- Fully electronic lever; the installed position sensor output can be customized
- Sensor output is redundant and can be chosen by the customer between 0 and 5V
- Equipped with 3 customizable switches - Standard version has High idle, warm, dock functions
- Provided with an easy adjustable brake tension release system
- Positive lock-in neutral to prevent accidental ingaging
- Equipped with a trim switch (standard version), but it's possible to request the version with the lock-in trigger, instead of the trim function.
- Thermoplastic material with a soft touch grip.

For the sensor configuration of B505-ESTC control, please contact our Technical Service Department.



B505L-ESTC

B505-ESTC

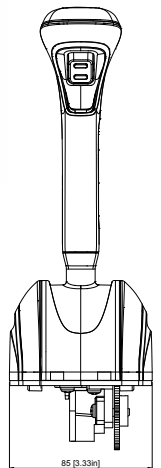

Customizable switches

Lever	Single lever
Lever control	Dual action control
Assembly	Top mount
Applications	Inboard, outboard, sterndrives, jet
Version	Electronic
Electronic Throttle Control	Yes
Output voltage range	Chosen by the customer between 0 & 5V
Power supply	5V +/-10%, linearity +/-1%
Adjustable friction	Yes
Engine warm up mode	Yes, if present on keypad
Positive lock-in neutral	Yes, in the locked version
Power trim switch	Yes, in the trim version
Emergency Safety Switch	No
Lever Stroke	+/- 66°

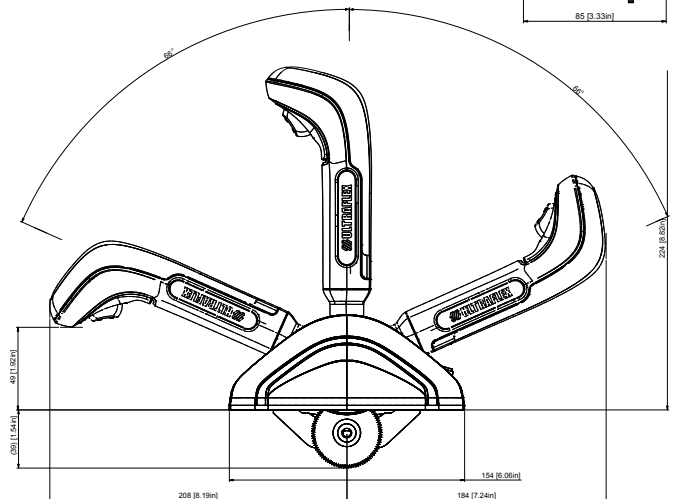

B505-ESTC	43581T	Black, with trim, with no emergency safety switch
B505L-ESTC	44145B	Black, with lock, with no emergency safety switch



## B204 - B208

### Twin lever top mount control - mechanical version



Two lever / single action control: each lever operates separately either the throttle or the shift

Suitable for any type of boat with inboard engine (with separate trim control) and jet.

- Flush mount suitable for exposed positions such as fly bridge
- Levers structure made of die cast zinc alloy provided with a soft thermoplastic ergonomical handgrip
- Adjustable friction to avoid throttle creep and positive detent for shift
- Provided with an interlock kit to prevent accidental gear engagement
- Adjustable ratchet for precise throttle operation obtained applying to the gas lever the optional kit K52 – 37382B
- Neutral safety switch **X12 – 34543Q** prevents in-gear starting
- Raked throttle handle and straight gear handle for a better manoeuvring
- Exceeds EN ISO 11547 standards

#### Control Cables

- For use with Ultraflex C2, C8, MACHZero and all 33C style engine control cables
- Ultraflex C22 and all 43C style cables require K22 – 34713Q connection kit



B204R with interlock



B208R with interlock

B204R	37383C	Throttle and shift - black
B208R	37654C	Throttle and shift - white

Lever	Single lever
Lever control	Dual action control
Assembly	Top mount
Applications	Inboard, jet boats
Version	Fully mechanical
Adjustable friction	Yes
X12 safety switch	Included
EN ISO 11547	Yes
Control cables	C2, C8, MachZero
Control cables that require a connection kit	C22 (K22)

## B204R - B208R (ETC - ESC - ESTC) Twin lever top mount control - hybrid version



Two lever / single action control: each lever operates separately either the throttle or the shift



Suitable for any type of boat with inboard engine or I/O power plants (with separate trim control) and jet.

- Especially suitable for jet boats, throttle and/or shift control is provided by a 0-5V voltage signal.
- Flush mount suitable for exposed positions such as fly bridge
- Levers structure made of die cast zinc alloy provided with a soft thermoplastic ergonomical handgrip
- Adjustable friction to avoid throttle creep and positive detent for shift
- Provided with an interlock kit to prevent accidental gear engagement
- Adjustable ratchet for precise throttle operation obtained applying to the gas lever the optional kit K52 – 37382B
- Neutral safety switch **X12** – 34543Q prevents in-gear starting
- Raked throttle handle and straight gear handle for a better manoeuvring
- Exceeds EN ISO 11547 standards

### Control cables

- For use with Ultraflex C2, C8, MACHZero and all 33C style engine control cables
- Ultraflex C22 and all 43C style cables require K22 – 34713Q connection kit

### Black finish

<b>B204R-ETC</b>	42832L	Throttle controlled by an electric signal, shift by a mechanical cable
<b>B204R-ESC</b>	42775B	Shift controlled by an electrical signal, throttle by a mechanical cable
<b>B204R-ESTC</b>	42776D	Throttle and shift controlled by an electrical signal

### White finish

<b>B208R-ETC</b>	42835T	Throttle controlled by an electric signal, shift by a mechanical cable
<b>B208R-ESC</b>	42833N	Shift controlled by an electrical signal, throttle by a mechanical cable
<b>B208R-ESTC</b>	42834R	Throttle and shift controlled by an electrical signal

<b>Lever</b>	Two lever
<b>Lever control</b>	Single action control
<b>Assembly</b>	Top mount
<b>Applications</b>	Inboard, jet boats
<b>Version</b>	Hybrid
<b>Adjustable friction</b>	Yes
<b>Output voltage range</b>	Chosen by the customer between 0 & 5V
<b>X12 safety switch</b>	Included
<b>EN ISO 11547</b>	Yes
<b>Control cables</b>	C2, C8, MachZero
<b>Control cables that require a connection kit</b>	C22 (K22)

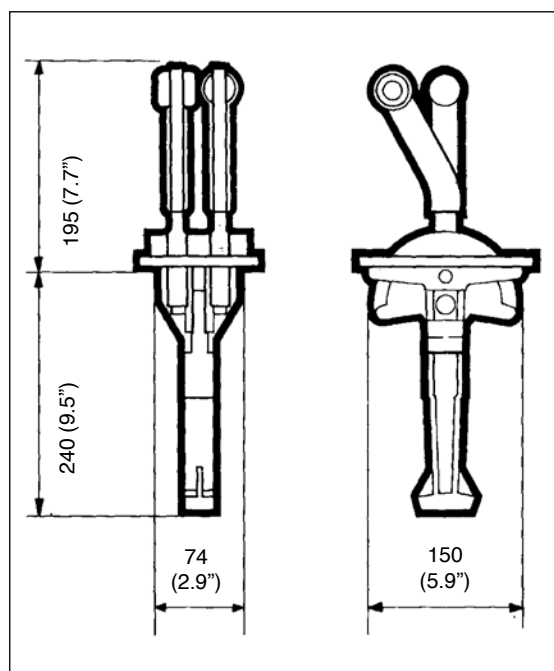

## B46 - B58 - B50 - B59

### Twin lever top mount controls

Two lever / single action control: each lever operates separately either the throttle or the shift.

Suitable for any type of boat with inboard engine.

- Flush mount suitable for exposed positions such as fly bridge
- Made of marine aluminum with chrome plated lever
- Adjustable friction to avoid throttle creep and positive detent for shift. Both can be adjusted from the outside
- Neutral safety switch **X12** – 34543Q prevents in-gear starting
- B58 model is provided with an interlock kit to prevent accidental gear engagement
- Exceeds EN ISO 11547 standards

#### Control cables:

For use with Ultraflex C2, C8 and MACHZero engine control cables.

Ultraflex C22 cable requires K22 – 34713Q connection kit

Lever	Two lever
Lever control	Single action control
Assembly	Top mount
Applications	Inboard
Version	Fully mechanical
Material	Marine aluminum
Adjustable friction	Yes
Lever Stroke	+/-95°
lock-in trigger	No
Power trim switch	No
X12 safety switch	Included
EN ISO 11547	Yes
Control cables	C2, C8, MachZero
Control cables that require a connection kit	C22 (K22)

#### Bent levers

<b>B46</b>	34461P	Throttle and shift
<b>B46T</b>	34462Q	Throttle only
<b>B46S</b>	34463R	Shift only
<b>B58R</b>	34570W	Throttle and shift with interlock. Right hand installation
<b>B58L</b>	34716T	Throttle and shift with interlock. Left hand installation



**Bent levers**  
B46  
B58 with interlock



**Straight levers**  
B50  
B59 with interlock

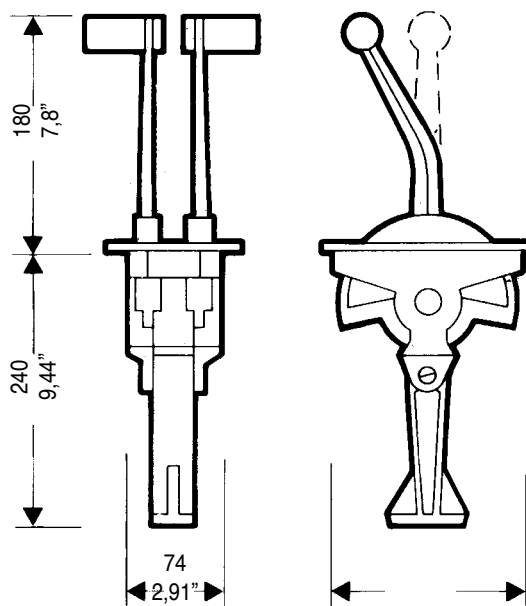

#### Straight levers

<b>B50</b>	34464S	Throttle and shift
<b>B50T</b>	34465T	Throttle only
<b>B50S</b>	34466U	Shift only
<b>B59R</b>	34571X	Throttle and shift with interlock. Right hand installation
<b>B59L</b>	34717U	Throttle and shift with interlock. Left hand installation



Two lever / single action control: each lever operates separately either the throttle or the shift.  
Suitable for any type of boat with inboard engine

- Made of aluminum, chrome plated finish
- Throttle lever is provided with adjustable friction system and shift lever with forward, reverse and neutral detents
- Neutral safety switch **X12** – 34543Q prevents in-gear starting
- In dual station applications the L23 – 31649B selector unit has to be used
- Exceeds EN ISO 11547 standards

**Control cables**

- Use with all Ultraflex control cables
  - C14 and MACH14 cables require no kit
  - For C2, C8 and MACHZero cables the connection kit K67 – 40705T is included
  - C5, C16 and MACH5 cables require K63 kit – 40757N
  - C22 cable requires K64 kit – 40758R
  - C36 and MACH36 cables require K65 kit – 40759T



**B322**

<b>B322</b>	40669S	Throttle and shift
<b>B322T</b>	40670A	Throttle only
<b>B322S</b>	40673G	Shift only

<b>Lever</b>	Two lever
<b>Lever control</b>	Single action control
<b>Assembly</b>	Top mount
<b>Applications</b>	Inboard
<b>Version</b>	Fully mechanical
<b>Material</b>	Aluminum
<b>Adjustable friction</b>	Yes
<b>X12 safety switch</b>	Included
<b>EN ISO 11547</b>	Yes
<b>Control cables</b>	C14, Mach14
<b>Control cables that require a connection kit</b>	C2, C8, MachZero (K59 incluso); C5, C16, Mach5 (K60); C36, Mach36 (K62); C22 (K64);

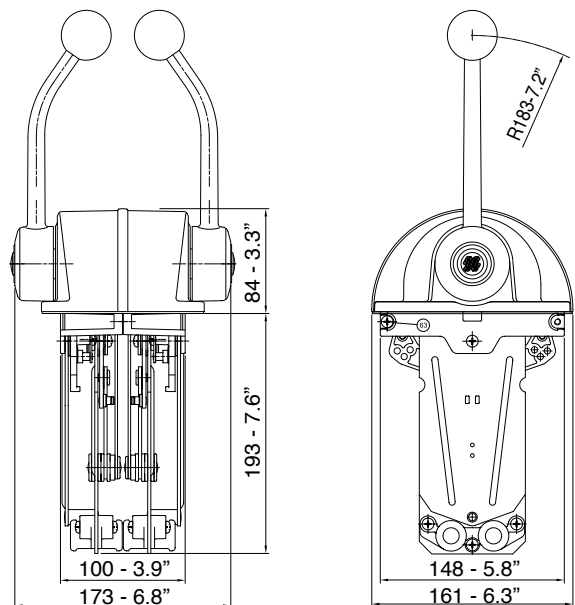

**B322**

## B99 - B102

### Twin lever top mount controls

Two lever / single action control: each lever operates separately either the throttle or the shift  
Suitable for any type of boat with inboard engine

- All the four versions are provided with the shift lever detents and with a friction system adjustable from the outside of the throttle lever
- Neutral safety switch **X12** – 34543Q prevents in-gear starting
- Exceeds EN ISO 11547 standards
- Suitable for exposed positions such as fly bridge

#### Control cables

- For use with Ultraflex C2, C8 and MACHZero engine control cables
- Ultraflex C22 cable requires K32 – 34662Z connection kit



B102

B99	36854N	Throttle and shift - Black painted with chrome levers
B102	36899G	Throttle and shift - Black painted



B99

Lever	Two lever
Lever control	Single action control
Assembly	Top mount
Applications	Inboard
Version	Fully mechanical
X12 safety switch	Included
EN ISO 11547	Yes
Control cables	C2, C8 MachZero
Control cables that require a connection kit	C22 (K32);

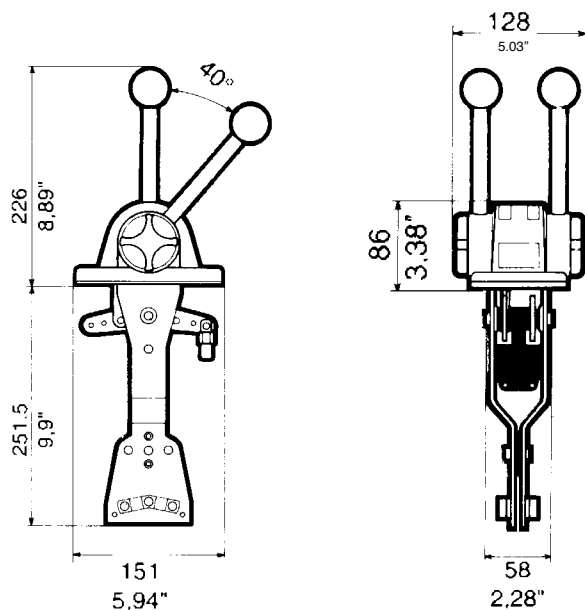

## B47 - B49 Twin lever side mount controls

Suitable for small outboard engines.

- Made of nylon fiberglass with anodized aluminum levers
- Left or right side mount installation

### Control cables

- For use with Ultraflex engine control cables:
  - C14 and MACH14 with K23 – 32773D connection kit
  - C2, C8, and MACHZero with K25 – 32775F connection kit
  - C5 and MACH5 without connection kit



B49

B47

Lever	Two lever
Lever control	Single action control
Assembly	Side mount
Applications	Outboard
Version	Fully mechanical
X12 safety switch	Included
EN ISO 11547	Yes
Control cables	C5, Mach5
Control cables that require a connection kit	C14, Mach14 (K23); C2, C8, MachZero (K25);

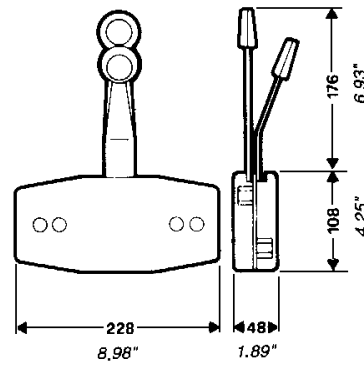

B47	32770A	Light gray
B49	33283S	Black

## B35 Single action control box

- Lever and flange all stainless steel
- Flush side mount installation
- Particularly suitable for throttle control or hydraulic shift operation
- Provided with adjustable friction and detents

### Control cables

- For use with Ultraflex C2, C8 and MACHZero engine control cables

Lever control	Single action control
Assembly	Side mount
Version	Fully mechanical
Control cables	C2, C8, MachZero

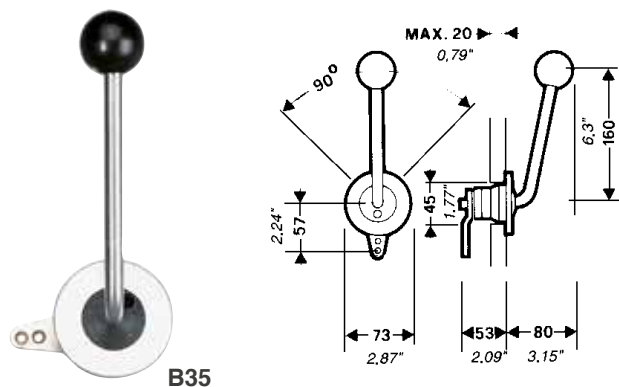

B35

B35	32386A	Stainless steel
-----	--------	-----------------



# Accessories for control boxes

**KB1 - 39964L**

Kit to connect C22 cable to B310, B183, B184 controls.

**K22 - 34713Q**

Kit to connect C22 cable to top mount two lever control boxes, B46, B50, B58, B59, B204, B208, B322

**K23 - 32773D**

Kit to connect C14 and MACH14 cables to B47 and B49 control boxes.

**K25 - 32775F**

Kit to connect C2, C8 and MACHZero cables to B47 and B49 control boxes.

**K32 - 34662Z**

Kit to connect C22 cable to top mount two lever control boxes B99 and B102.

**K33 - 38378D**

Kit to connect C22 cable to B103 control box.

**K35 - 34730U**

Kit to connect C5, C16 and MACH5 cables to single lever control boxes, except B301, B302, B103 and B104.

**K51 - 32526N**

Kit to connect C14 and MACH14 cables to engine for use with B89 and B90 controls.

**K59 - 40144C**

Kit to connect C2, C8 and MACHZero cables to B301 and B302 controls (supplied with the box).

**K60 - 40145E**

Kit to connect C5, C16 and MACH5 cables to B301 and B302 control boxes.

**K61 - 40146G**

Kit to connect C22 cable to B301 and B302 control boxes.

**K62 - 40147J**

Kit to connect C36 and MACH36 cables to B301 and B302 control boxes.

**K63 - 40757N**

Kit to connect C5, C16, MACH5 cables to B322 controls.

**K64 - 40758R**

Kit to connect C22 cable to B322 controls.

**K65 - 40759T**

Kit to connect C36 and MACH36 cables to B322 controls.

**K67 - 40705T**

Kit to connect C2, C8 and MACHZero cables to B322 controls (supplied with the box)

**K74 - 44170A**

Kit to connect C5 and MACH5 cables to B110 and B120controls

**K75 - 44171C**

Kit to connect C36 and MACH36 cables to B110 and B120controls

**K76 - 44172E**

Kit to connect C14 and MACH14 cables to B110 and B120 controls

**K83 - 42836V**

Kit to connect C48 cable to B310, B183, B184 controls

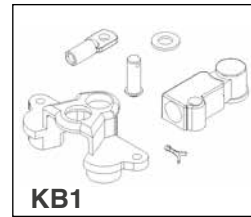

**KB1**

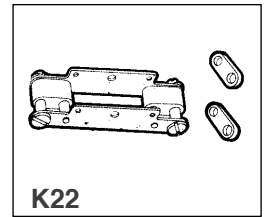

**K22**

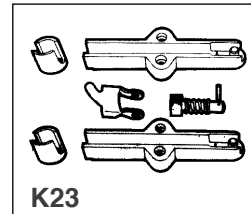

**K23**

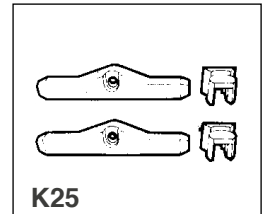

**K25**

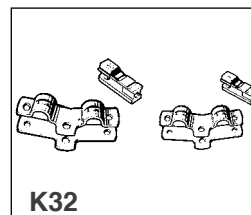

**K32**

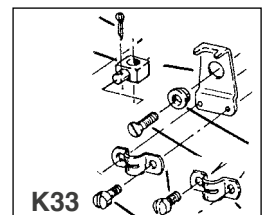

**K33**

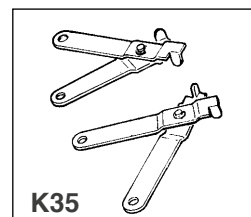

**K35**

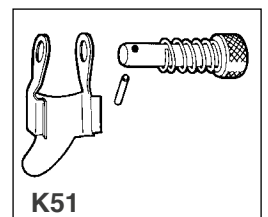

**K51**

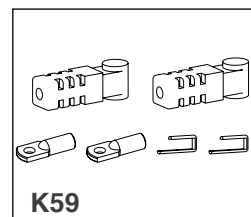

**K59**

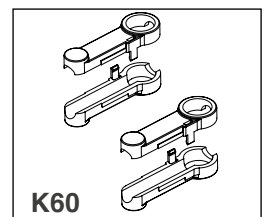

**K60**

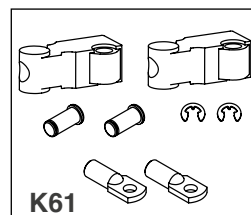

**K61**

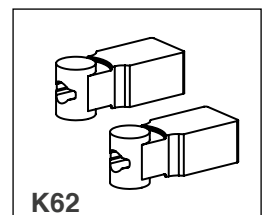

**K62**

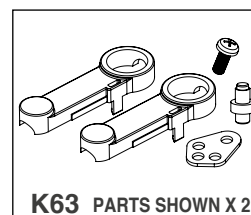

**K63 PARTS SHOWN X 2**

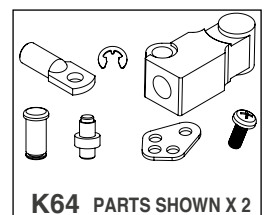

**K64 PARTS SHOWN X 2**

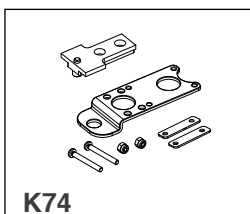

**K74**

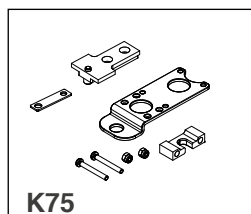

**K75**

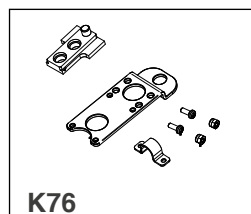

**K76**

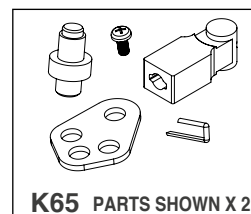

**K65 PARTS SHOWN X 2**

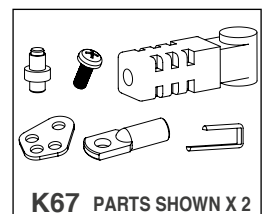

**K67 PARTS SHOWN X 2**

## Accessories for control boxes

### X12 - 34543Q

Neutral safety switch to prevent in-gear starting.

### X41 - 38130F

Neutral safety switch to prevent in-gear starting, suitable for B400, B110, B120 and hybrid controls. IP67 protection.

### X43 - 38160L

Neutral safety switch to prevent in-gear starting, suitable for B103 and B104 controls.

### X48 - 43527L

Neutral safety switch to prevent in-gear starting, suitable for B110 and B120 controls. It allows to connect a double signal. IP67 protection.

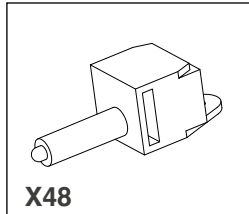
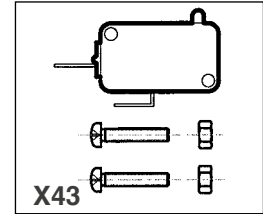
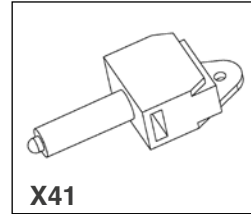
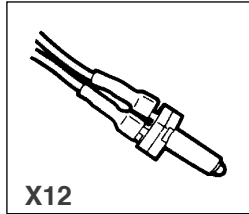

## Control box - control cable application matrix

### Single lever controls

MODEL	B400	B183 - B184 - B85 B310 Series	B110 B120	B301 - B302 B501 Series	B103	B104	B73 - B74 B77 - B79	B89 - B90
C2	X	X	X	K59*	X	X	X	X
C8	X	X	X	K59*	X	X	X	X
C14	-	X	K76	X	-	-	X	X
C5	-	K35	K74	K60	-	-	K35	K35
C36	-	-	K75	K62	-	-	-	-
C16	-	K35	-	K60	-	-	K35	K35
C22	-	-	-	K61	K33	-	-	-
MACHZero	X	X	X	K59*	X	X	X	X
MACH5	-	K35	K74	K60	-	-	K35	K35
MACH36	-	-	K75	K62	-	-	-	-
MACH14	-	X	K76	X	-	-	X	X

\*: Supplied with the control

X: No kit required

- : No connection

### Twin lever controls

MODEL	B322	B46 - B50 - B58 B59 - B204R - B208R	B99 - B102	B47 - B49	B35
C2	K67*	X	X	K25	X
C8	K67*	X	X	K25	X
C14	X	-	-	K23	-
C5	K63	-	-	X	-
C36	K65	-	-	-	-
C16	K63	-	-	X	-
C22	K64	K22	K32	-	-
MACHZero	K67*	X	X	K25	X
MACH5	K63	-	-	X	-
MACH36	K65	-	-	-	-
MACH14	X	-	-	K23	-

\*: Supplied with the control

X: No kit required

- : No connection

# Engine control cables

## How to measure



FOR NEW INSTALLATION, measure A + B distance from the control along an unobstructed cable routing to clutch and / or throttle connection.

Round this dimension off to the next whole foot: you will have your cable length.

We recommend that the cable bends have a minimum radius of about 8" (200 mm).

For outboard engine installations, it is necessary to add three feet to the obtained length, in order to allow the engine movement.

To determine the needed length of the REPLACEMENT CABLE, measure it from tip to tip.

When ordering, specify the cable length in feet, rounding the dimension off to the next whole value.

If any kit is required to complete the cable connection, consult the appropriate section in this catalogue.

### OUTBOARD

$$A + B + 3' (90 \text{ cm}) = L$$

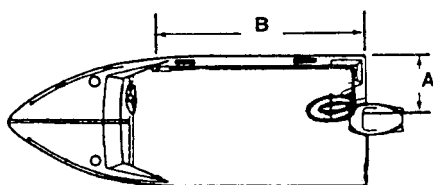

### INBOARD/STERNDRIVE

$$A + B = L$$

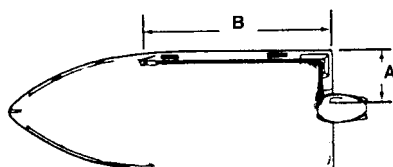

### SELECTION OF ENGINE CONTROL CABLES

	ENGINE	ULTRAFLEX ENGINE CONTROL CABLES	
OUTBOARD	Mercury <sup>®</sup> and Gen. II <sup>™</sup> Controls	C36 - MACH36	
	Mercury <sup>®</sup> Mariner <sup>®</sup> over 50 hp (37kW)	C5 - MACH5	
	Mariner <sup>®</sup> up to 50 hp (37kW)	C16	
	Force <sup>®</sup> Selva <sup>®</sup> Yamaha <sup>®</sup> Suzuki <sup>®</sup> Tohatsu <sup>®</sup> Honda <sup>®</sup> Nissan <sup>®</sup>	C2 - C8 - MACHZero	
	Johnson <sup>®</sup> - Evinrude <sup>®</sup> - BRP <sup>®</sup>	After 1979 C14-MACH14	
	JET	Weber <sup>®</sup>	C40 - C48
		Rotax <sup>®</sup>	C40RT - C42RS
STERNDRIVE	Mer cruiser <sup>®</sup> and Gen. II <sup>™</sup> Controls	C36 - MACH36	
	Mer cruiser <sup>®</sup>	C5 - MACH5	
	OMC <sup>®</sup> - BRP <sup>®</sup>	After 1979 C14-MACH14	
	Volvo Penta <sup>®</sup> Yanmar <sup>®</sup> Volkswagen <sup>®</sup>	C2 - C8 MACHZero - C22	
INBOARD		C2 - C8 - MACHZero - C22	

# MACH™ series control cables

## High efficiency and flexibility

For the ultimate in efficiency and response, the Mach Series cables deliver unmatched results. They have been specifically designed to make even the most complex of cable installations result in smooth, easy and precise shift and throttle movement.



### High Performance

The PATENTED “high performance” MACH™ Cables are the result of our decades of experience in producing high quality, long lasting, flexible cables.

The innovative core design maximizes efficiency and minimizes lost motion, while the exclusive design of the conduit provides extremely high level of flexibility.



### Features & performance

- Available in the following configurations:
  - **MACHZero** - Universal style (like C2, C8)
  - **MACH5** - Mercury® style (like C5)
  - **MACH14** - Current OMC® - BRP® style (like C14)
  - **MACH36** - Gen II Mercury® style (like C36)
- Suitable for outboard – inboard and sterndrive engines
- High efficiency for smooth operation
- High flexibility for reduced bend radius. Ideal for long complex cable routings
- Maintenance free
- Stainless steel cables end fittings
- High resistance blue outer jacket against abrasion, UV and chemicals



**MACHZero**

**MACH5**

**MACH14**

**MACH36**

### Control cables for Jet engines

**C40** Stroke: 86 mm (3.4")  
Throttle Cable for Weber® jet engines

**C48** Stroke: 84 mm (3.3")  
Shift and throttle cable for jet boats 40 Class. Suitable for Teleflex® controls. With K83 - 42836V connection kit is suitable for use with Ultraflex B310, B183, B184 controls.

**C40RT** Throttle Cable for Rotax® jet engines

**C42RS** Shift Cable for Rotax® jet engines

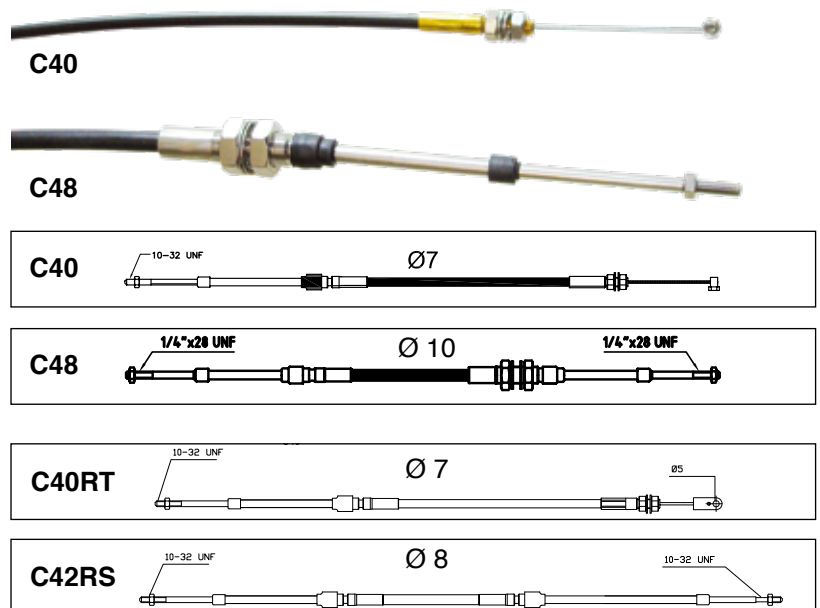

# Engine control cables

**C2** Stroke: 87 mm (3.4")  
For use with inboard, sterndrive and outboard engines with appropriate accessories.

**C8** Stroke: 87 mm (3.4")  
For use with inboard, sterndrive and outboard engines, with appropriate accessories.

**MACHZero** 87 mm (3.4")  
For use with inboard, sterndrive and outboard engines.  
Ideal for high performance applications, long cable runs and complex routings. Blue color jacket.

**C14** Stroke: 75 mm (3")  
For BRP® - Evinrude® (OMC®) engines manufactured from 1979 to date.

**MACH14** Stroke: 75 mm (3").  
For BRP® - Evinrude® (OMC®) engines manufactured from 1979 to date.  
Blue color jacket  
High performance applications

**C36** Stroke: 87 mm (3.4")  
For Mercury® and Mercruiser® engines and Mercury® Generation II™ series controls.

**MACH36** Stroke: 87 mm (3.4").  
For Mercury® and Mercruiser® engines and Mercury® Generation II™ series controls.  
Blue color jacket  
High performance applications

**C5** Stroke: 95 mm (3.75")  
For Mercury® and Mercruiser® engines.

**MACH5** Stroke: 95 mm (3.75").  
For Mercury® and Mercruiser® engines.  
Blue color jacket  
High performance applications

**C16** Stroke: 80 mm (3.1"). For Mariner® engines up to 40 hp.

**C22** Stroke: 80 mm (3.1")  
Stainless steel clamp fittings. Recommended for heavy duty applications.

**B14** Stroke: 70 mm (2.8")  
Designed for throttle, fuel shut-off and other applications. Supplied with L13 and L14 clamp and shim.

**C40** Stroke: 86 mm (3.4")  
Throttle Cable for Weber® jet engines

**C48** Stroke: 84 mm (3.3")  
Shift and throttle cable for jet boats 40 Class

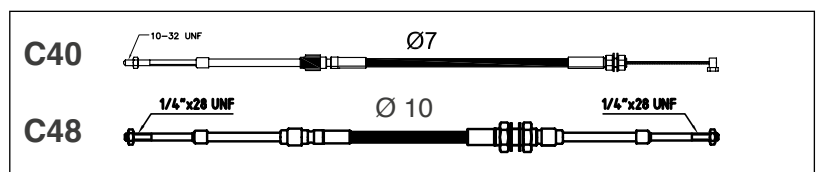
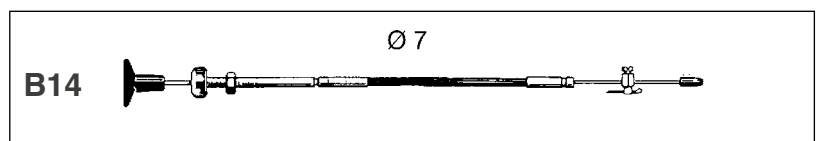
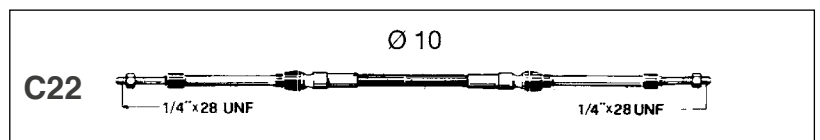
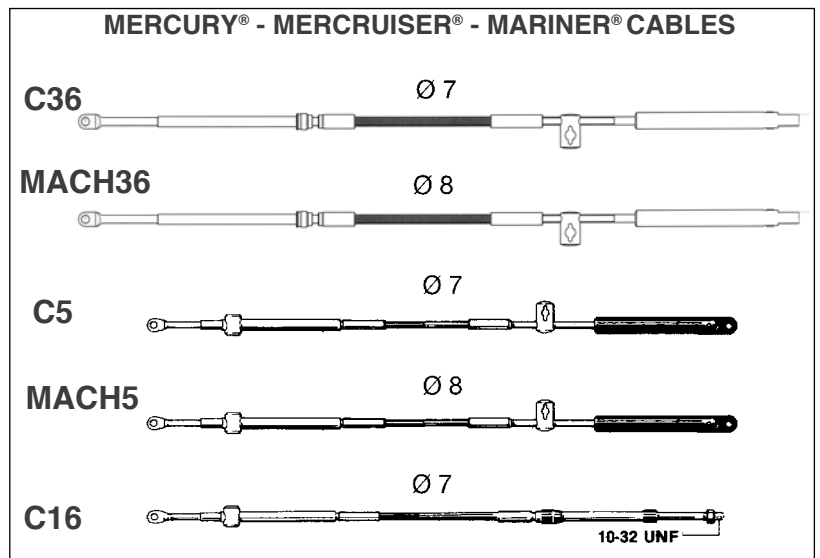
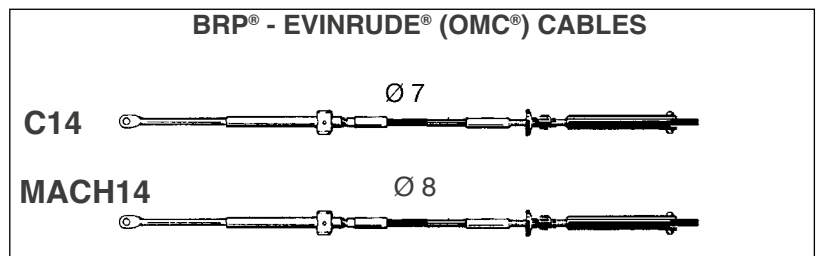
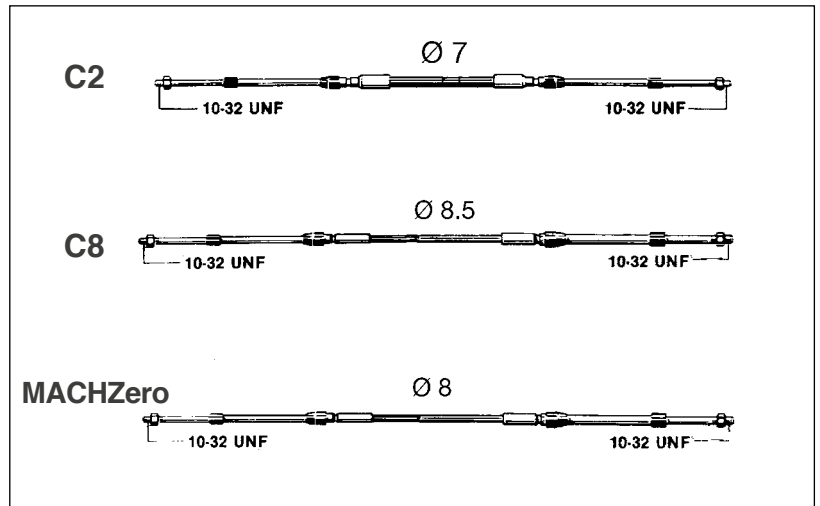

## Accessories for engine control cables

### K68 - 40895B

Recessed bulkhead support for B14 cable.

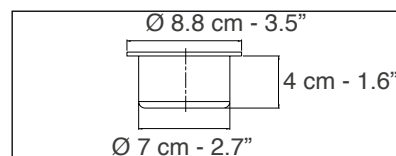

### L2 - 30324D

Cable clamp block

### L3 - 30325E

Shim and clamp block.

Fits C2, C8 and MACHCZero cables.

### L7 - 38078U

Ball joint 10-32 UNF.

Stainless steel, fits C2, C8 and

MACHCZero cables.

### L12 - 30334F

Cable end fitting.

Fits C2, C8 and MACHCZero cables.

### L13 - 30335G

Stop collar. Fits B14 cables.

### L14 - 30336H

Cable clamp block.

Fits C2, C8 and MACHCZero cables.

### L25 - 31906D

Clevis 10-32 UNF.

Fits C2, C8 and MACHCZero cables.

### L26 - 33517N

Clevis 1/4" x 28 threaded.

Fits C22 cable.

### L28 - 43228A

0.3" cable terminal.

Fits C48 Jet boat cable.

### K56 - 39237C

Adapts C2, C8 and MACHCZero cables for use with Mercury engines.

### K57 - 39238E

Adapts C2, C8 and MACHCZero cables for use with BRP® - Evinrude engines.

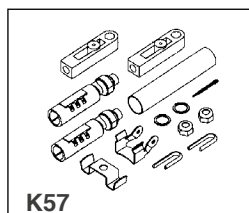
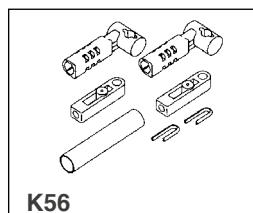
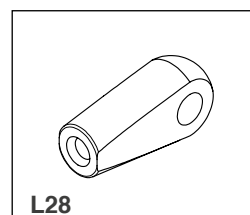
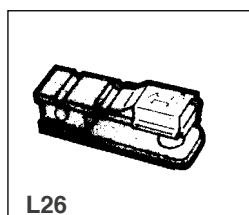
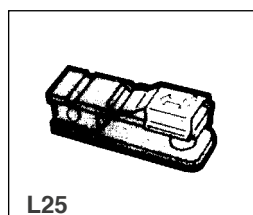
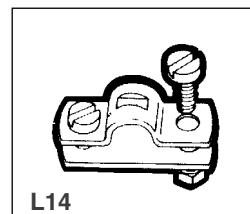
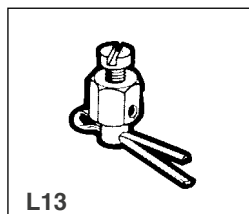
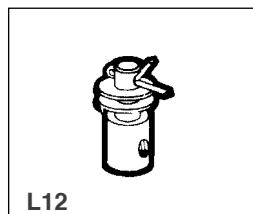
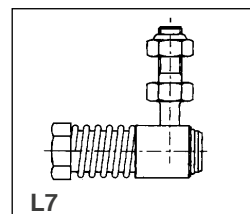
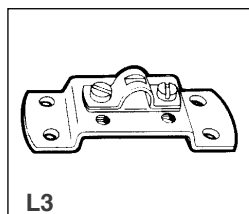
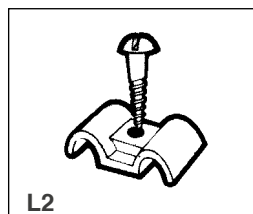

## Monofilament polyester braided sleeves for cables

Available in UFLEX

### STANDARDS:

- Compliant with RoHS 2002/95/CE specifications
- NF EN 60684-1 (10-2003)
- NF EN 60684-2 (01-1998) modified by  
NF EN 60684-2/A1 (12-2003)  
NF EN 60684-2/A2 (05/2006)
- NF EN 60684-3 sheets 340 to 342 (4-2003)



RoHS

NOMINAL INTERNAL DIAMETER	PART No. 1 m length	PART No. 10 m length	PART No. 20 m length	BULK PART No. 100 m length	ROLL WEIGHT Kg
10 mm (0.39")	23622S	24853T	24858D	68180N	8,0
15 mm (0.59")	23623U	24854V	24859F	20540Y	12,16
20 mm (0.78")	23624W	24855X	24863W	20542C	17,8
25 mm (0.98")	23625Y	24856Z	24861S	20543E	20,2
30 mm (1.18")	23626A	24857B	24862U	20544G	27,0



# Accessories for engine control cables

## Throttle converter

The Throttle Converter allows to steer a tension controlled engine with a mechanical control box.

The system converts the mechanical input from a control cable into an electrical output to the engine.

Suitable either for new installations and refitting, it allows to use an existing mechanical control and connect it to the electrical input of the new engine's throttle.

Throttle Converters can be easily packed together for multiple engines.

- Equipped with 1 m (3.28 ft) mechanical cable with C2, C8 universal end fitting
- 76 mm (3") minimum stroke, 80 mm (3.15") maximum stroke.
- 30 cm (1 ft) electrical wire length

Throttle Converter is suitable for most of the voltage controlled engines. For further information, please contact our Technical Assistance Service

Mechanical side IP65  
Sensor IP67

**Throttle converter TC - 43501S**

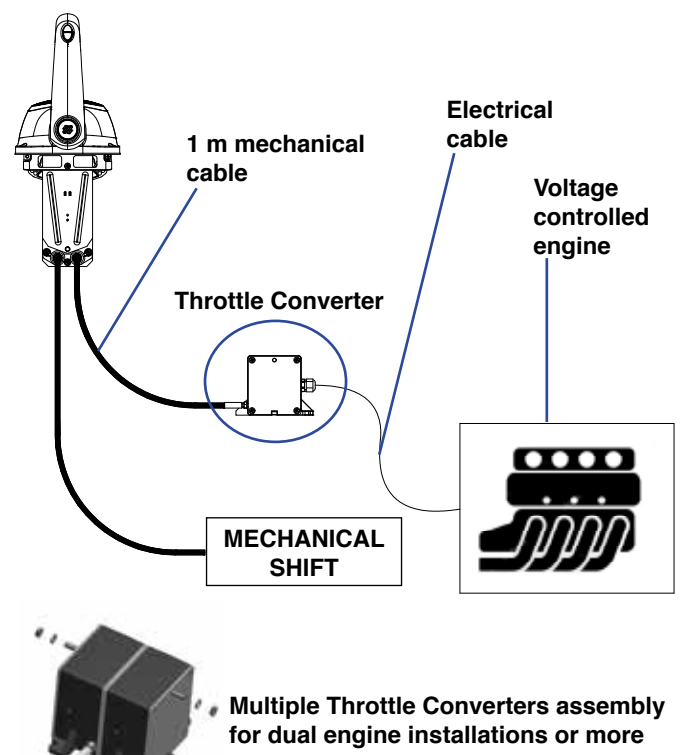

## Selector unit for dual station applications

Selector unit for use with single lever controls in dual station applications. It enables independent control over throttle and shift from either the main station or the flying bridge station.

**NOTE:** before changing station, throttle must be on idling position and shift in neutral.

**L23** - 31649B - only for inboard and sterndrive engines



## YAMAHA engine kits 2T \*

**K8** - 30321A for 25 hp engines

**K14F** - 38098C for 10/15 hp engines

**S-2674** - 32654X Yamaha Throttle Connector

**S-2675** - 32655Y Yamaha Shift Connector

\* Minimum order quantity:  
10 pieces for part number

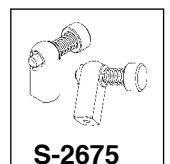
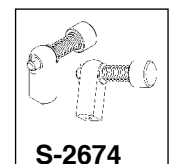

## Available spare parts

## Mechanical products

### WARNING

In order to maintain the correct functionality of the product, the replacement with spare parts has to be made by qualified technicians only.

<b>T67</b>	
Black bezel	59336W
White bezel	59601U
Zinc-chrome steel bushing	56402K
Installation kit	38070K
Shaft kit	70550J
<b>M58</b>	
Lock nut engine side	55170M
<b>T85</b>	
Black bezel	59336W
White bezel	59601U
Shaft kit	70549A
Spent travel nylon tube	59869F
Plastic ferrule for nylon tube	59857Z
Cable lock-in screw	59926R
Installation kit	41165S
<b>T71FC - T72FC - T73NRFC</b>	
90° Black bezel	58051L
90° White bezel	71942H
20° Black bezel	70068H
Shaft kit	70549A
Cable lock-in screw	70022G
Spent travel nylon tube	59869F
Plastic ferrule for nylon tube	59857Z
<b>T91 - T93ZT</b>	
90° Black bezel	58051L
90° White bezel	71942H
20° Black bezel	70068H
Shaft kit	70549A
Cable lock-in screw	74871C
Spent travel nylon tube	59869F
Plastic ferrule for nylon tube	59857Z
<b>X52 - X66 Tilt Mechanisms</b>	
Upper cover	72297K
Lower cover	70140N
Gasket	70138C
<b>X82 - X88 Tilt Mechanisms</b>	
Upper cover	44175L
Lower cover	44176N
Docking clip	44177R
<b>TM87J - TM87O</b>	
Screw kit	77229U
Steering system cap kit	43894R
<b>Steering Wheels</b>	
Stainless steel TS silver screws	60697Q
Stainless steel TS black screws	60698T
Stainless steel TB silver screws	66734W
Black cap for V32	58078Y
White cap for V32	58079Z
Gray cap for V32	70155C
Black cap for V33	59763O
White cap for V33	59764P
Gray cap for V33	59765Q
Black cap for V45	59061O
White cap for V45	59002D
Gray cap for V45	71108Y
Black cap for V38	59061O
White cap for V38	59002D
Black cap for Antigua	70161X
White cap for Antigua	70162Z
Gray cap for Antigua	70163B
Wood cap for V23 and V35	56384G
<b>B301CR - B302CR - B301B - B302B - B322</b>	
Lever assembly with black knob	40897F
Lever assembly with red knob B322	40898H
Black knob	72054G
Red knob	72020N
Chrome rear cover B301CR	71461R
Black painted rear cover B301B	71501A
Gasket for B301CR - B301B	71366X
Gasket for B302CR - B302B - B322	71516P

## Available spare parts

## Mechanical products

Installation kit B301	40170D
Installation kit B302	40192P
Installation kit B322	40703N
<b>B400</b>	
Screw kit	43866K
<b>B501 - B502</b>	
B501 coponents kit	43128W
B502 components kit	43129Y
<b>B103 - B104</b>	
Lever with handle	60909N
Black knob	34830001
X55 Silver knob B103/B104	39421V
Gasket for B103	61425E
Gasket for B104	61426G
Rear cover for B103	61738C
Installation kit B103	60979B
Installation kit B104	60804D
<b>B65 - B66 - B73 - B74 - B76 - B77 - B78 - B79</b>	
Lever assembly B66 – B65 – B73 – B74	57076R
Lever assembly with trim B76-B77-B78-B79	57459E
Chrome rear cover	55529Z
Black rear cover	55608X
Installation kit B65	35147J
Installation kit B66	30078K
Installation kit B73	30049F
Installation kit B74	35366S
Installation kit B76	36134F
Installation kit B77	30016Q
Installation kit B78	36135G
Installation kit B79	30017R
<b>B310CH - B310BR - B310B</b>	
Lever assembly B310CH	73158A
Lever assembly B310BR	72119J
Lever assembly B310B	73177E
Screw cover flange B310CH - B310BR - B310B	72110P
Chrome plated external flange B310CH - B310BR - B310B	72108D
Black internal flange B310CH - B310BR - B310B	72109F
Installation kit B310CH - B310BR - B310B	72222B
<b>B183 - B184 - B85</b>	
Lever assembly B183	70013F
Lever assembly B184	70020C
Cover for B183 – B184 – B85	56012A
Flange for B183 – B184 – B85	56011V
Installation kit B103	38947F
Installation kit B184	38979V
Installation kit B85	36008C
<b>B89 - B90</b>	
Black lever with lock	58245T
White lever with lock	57899L
Installation kit B89 - B90	36168R
<b>B46 - B50 - B58 - B59</b>	
Cover	57960T
Black knob	32394A
Red knob	32472Q
Installation kit	35365R
<b>B99 - B102</b>	
Red knob B99 – B102	58266Y
Black knob B99 – B102	53185V
Installation kit B99 – B102	35391A
<b>B14 Engine Stop Cable</b>	
B14 Kit	59976G
<b>B110 - B120</b>	
Switch with Logo	43644R
Lever assembly B110	43645T
Lever assembly B120	44174J
Flange + seal kit	43646V
Screw kit	43647X
33C cables screw kit	43648Z

### WARNING

In order to maintain the correct functionality of the product, the replacement with spare parts has to be made by qualified technicians only.

## Available spare parts

## Hydraulic products

### WARNING

In order to maintain the correct functionality of the product, the replacement with spare parts has to be made by qualified technicians only.

### B505

Seal kit	43649B
Top and side cover kit	43650K

### HELM PUMPS

Vented filler plug kit with valve	40801N
Non vented filler plug kit	40800L
Shaft seal kit from UP25 to UP39	40875V
Shaft seal kit for UP20	42310D
Installation kit for UP20 F	42861U
Installation kit for UP20 T	42864A
Installation kit for: UP25 F/25 F/28 F/33 F/39 F/45 F and UP28-SVS	42862W
Installation kit for UP25 T/28 T/33 T/39 T/45T	42864A
Installation kit for UP28 R/33 R/39 R/45 R	42863Y
Nylon round flange for X57	70666E
Nylon square flange for X64	70670V
Chrome plated cover ring - X68	40894Z
Pump filling kit	42960W

### UC81-OBF OUTBOARD CYLINDER

Bull horn mounting bracket	42851R
Through tube stainless steel rod	42852T
Spacer kit	42853V
Tiller arm connecting	42854X
Replaceable heads kit + Seal kit + Tool kit	43473P

### UC94-OBF OUTBOARD CYLINDER (DISCONTINUED)

Black bull horn mounting bracket	42837X
Through tube stainless steel rod	42666W
Spacer kit	40878B
Tiller arm connecting	42838Z
Seal kit for UC94-OBF P. No: 40154F, 40161C	41919U
Tool kit for UC94-OBF P. No: 40154F, 40161C	41920C
Seal kit for UC94-OBF P. No: 42918X, 42968N	43174D
Tool kit for UC94-OBF P. No: 42918X, 42968N	43175F

### UC95-OBF OUTBOARD CYLINDER

Black bull horn mounting bracket	42837X
Through tube stainless steel rod	42666W
Spacer kit	40878B
Tiller arm connecting	42838Z
Tool kit for UC95-OBF	43446L
Replaceable heads kit for UC95-OBF	43444G

### UC128-OBF OUTBOARD CYLINDER

Black bull horn mounting bracket	43248G
Through tube stainless steel rod	39491T
Spacer kit	41812Z
Plastic cap kit	41810V
UC128 Hardware kit (link arm)	39979A
Tiller arm connecting kit (ultrabolt)	40822X
Shaft screws kit	43255D
Replaceable heads kit for UC128-OBF P. No: 43231N, 43232R, 43233T, 43234V, 43235X	43350X
Tool kit for UC128-OBF P. No: 43231N, 43232R, 43233T, 43234V, 43235X	43395W

### UC128-SVS OUTBOARD CYLINDER

Tiller arm connecting kit (ultrabolt)	42081R
Tool kit for UC128-SVS P.No. 43870A, 43872E, 43871C, 43873G	43868P
Replaceable heads kit for UC128-SVS 43870A, 43872E, 43871C, 43873G	43869S

### UC130-SVS OUTBOARD CYLINDER

Tiller arm connecting kit (ultrabolt)	42081 R
Replaceable heads kit for UC130-SVS P.No: 43225U, 43226W, 43223P, 43224S	43364J
Tool kit for UC130-SVS P.No: 43225U, 43226W, 43227Y	43386V

## Available spare parts

## Hydraulic products

### UC128-BB OUTBOARD CYLINDER

Tiller arm connecting kit (ultrabolt)	42081R
Tool kit for UC128-SVS P.No. 43870A, 43872E, 43871C, 43873G	43868P
Replaceable heads kit for UC128-SVS 43870A, 43872E, 43871C, 43873G	43869S

### UC120 OUTBOARD CYLINDERS

Replaceable heads kit for UC120 cylinder	43572S
Tool kit for UC120 cylinder	43614F

### UC68-OBS OUTBOARD CYLINDER

Stainless steel tilt tube extension	39495B
-------------------------------------	--------

### UC132-OBS OUTBOARD CYLINDER

Stainless steel tilt tube extension	39495B
Extension rod connecting pin	40917J

### ZTF

Replaceable heads kit for UC128-ZTF cylinder	43350X
Tool kit for UC128-ZTF cylinder	43395W
Tilt tube stainless steel rod	42666W
Spacer kit	41812Z
Plastic cap kit	41810X
Engine rod bolt and screw kit	41809L
KIT M2 (Mercury®) mechanical cables	43642L
KIT Y (Yamaha®) mechanical cables	43640G
KIT S2 (Suzuki®) mechanical cables	43641J
KIT ND1-MM (Mercury®)	43636S
KIT ND1-Y (Yamaha®)	43639Y
KIT QU1-Y (Yamaha®)	43638W
KIT QU1-S (Suzuki®)	43635P
Nickel plate plug+ o-ring kit	43637U

### INBOARD CYLINDERS

Balljoint for UC69-I	40883U
Balljoint for UC116-I	39477Z
Balljoint for UC168-I and UC215-I	39478B
Balljoint for UC293-I	40178W
Balljoint for UC378-I	41310Y
Balljoint and shim for UC69-I	40884W
Balljoint and shim for UC116-I	39479D
Balljoint and shim for UC168-I and UC215-I	39480M
Balljoint and shim for UC293-I	40180G
Balljoint and shim for UC378-I	41311A

### STERNDRIVE CYLINDERS

Extension rod connecting pin	40917J
------------------------------	--------

### NUT AND SLEEVE

Brass nut and sleeve	71004K
Nickel plated brass nut and sleeve	71013L

### WARNING

In order to maintain the correct functionality of the product, the replacement with spare parts has to be made by qualified technicians only.

# UES<sup>®</sup>

ULTRAFLEX CONTROL SYSTEMS Srl





# AV SERIES ELECTRICAL HATCH LIFTERS

The AV hatch lifters are electromechanical products, especially designed for marine use on pleasure boats.

They allow full or partial opening and closing of heavy engine hatches, peak tanks, hatch beams etc.

By activating a switch, it is possible to lift the hatch to any desired position from closed to full open; an internal self-locking mechanism will maintain the position preventing any accidental hatch closing. In case of a power failure an emergency device allows for manual opening.

## TECHNICAL FEATURES

- According to the load required, the AV hatch lifter can be mounted individually, or in twin cylinder installation for heavier loads.
- **Maximum load for single installations: 1200N (120 kg - 265 lbs)**
- **Maximum load for dual installations: 2400N (240 kg - 529 lbs)**
- Maximum load is recommended not to be exceeded.
- Supplied with all mounting hardware.
- Stainless steel telescopic ram for manual operation in case of emergency.
- Circuit breaker to stop accidental overloading of the system and electronic stop at closed or full open position.
- IP 65 protection rated
- Speed: 25mm/sec no load applied, 17 mm/sec maximum load
- Current absorption in single installations: 10A at 12V, 5A at 24V
- Current absorption in dual installations: 20A at 12V, 10A at 24V
- AV 12VDC models are Ignition Protected. UL1500 - ISO8846 approved.

NOTE: Available, on request, the push/pull actuator version. This option is not compatible with the manual emergency opening device.



CE

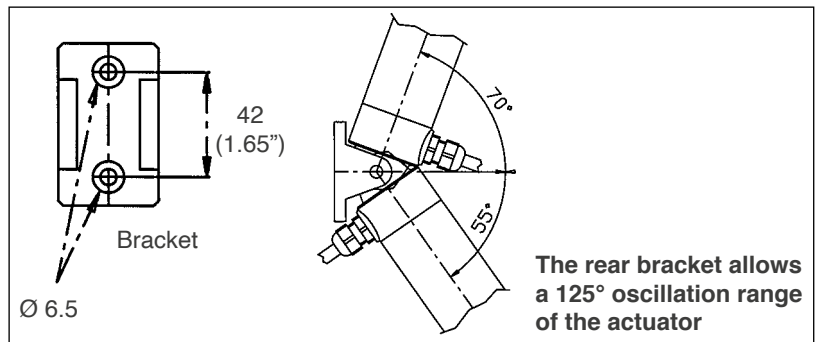
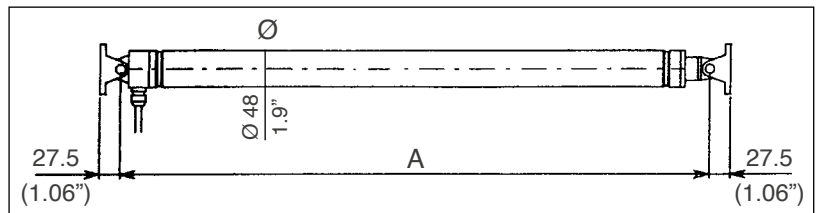

MODEL	PART No.	VOLTS	STROKE	LENGTH A (FULL CLOSED ACTUATOR)	EXTERNAL DIA.
AV 3012	40671C	12V DC	300 mm (12")	677 mm (26.6")	48 mm (1.9")
AV 3024	40672E	24V DC	300 mm (12")	677 mm (26.6")	48 mm (1.9")
AV 4512	40582D	12V DC	450 mm (18")	827 mm (32.5")	48 mm (1.9")
AV 4524	40583F	24V DC	450 mm (18")	827 mm (32.5")	48 mm (1.9")
AV 6012	40584H	12V DC	600 mm (24")	977 mm (38.4")	48 mm (1.9")
AV 6024	40585K	24V DC	600 mm (24")	977 mm (38.4")	48 mm (1.9")

## OPTIONAL COMPONENTS

**RB12** - 40738Y Relay box 12V

**RB24** - 40742C Relay box 24V

It contains the relays needed for cycle reversion. One box works with 1 or 2 lifters

**SW20** - 69116J

1 x 3 way single pole momentary switch

**BR/AV-** 80382I Spare fixing bracket



SW20



RB12

# ULYSSES SERIES ELECTRICAL HATCH LIFTERS

## TECHNICAL FEATURES

- **Single installation only**
- **Pull and push maximum load: 650N (65 kg - 144 lbs)**
- Pull and push maximum load is recommended not to be exceeded.
- Supplied with all mounting hardware.
- Aluminum ram.
- Circuit breaker to stop accidental overloading of the system and electronic stop at closed or full open position.
- IP 65 protection rated
- Speed:
  - 12V model:
    - 5 mm/sec no load applied
    - 4 mm/sec maximum load
  - 24V model:
    - 8 mm/sec no load applied
    - 6 mm/sec maximum load
- Current absorption: 2A at 12V, 1A at 24V

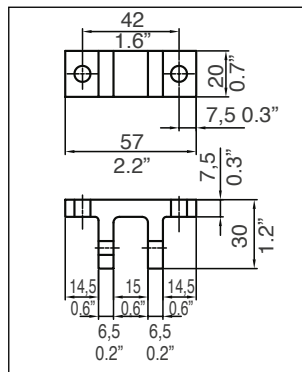
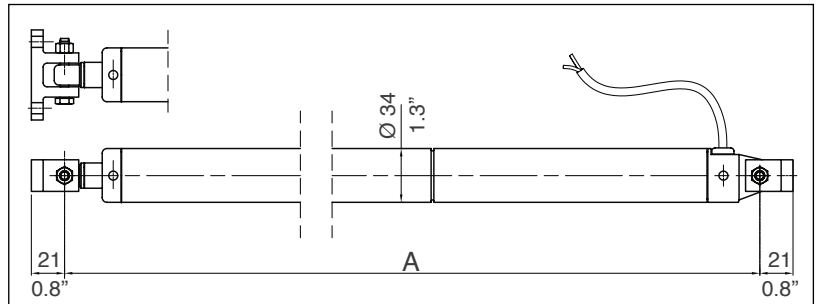

**Highest installation flexibility: 180° oscillation range**

MODEL	PART No.	VOLTS	STROKE	LENGTH A (FULL CLOSED ACTUATOR)	EXTERNAL DIA.
ULYSSES 1812	40924Q	12V DC	180 mm (7")	515 mm (20.3")	34 mm (1.3")
ULYSSES 1824	40926S	24V DC	180 mm (7")	515 mm (20.3")	34 mm (1.3")
ULYSSES 3012	40925R	12V DC	300 mm (12")	635 mm (25.0")	34 mm (1.3")
ULYSSES 3024	40927T	24V DC	300 mm (12")	635 mm (25.0")	34 mm (1.3")

## OPTIONAL COMPONENTS

**SW20 - 69116J**  
1 x 3 way single pole momentary switch

**BR/UL - 35697P**  
Spare fixing bracket



SW20

# AV AND ULYSSES SERIES ELECTRICAL HATCH LIFTERS

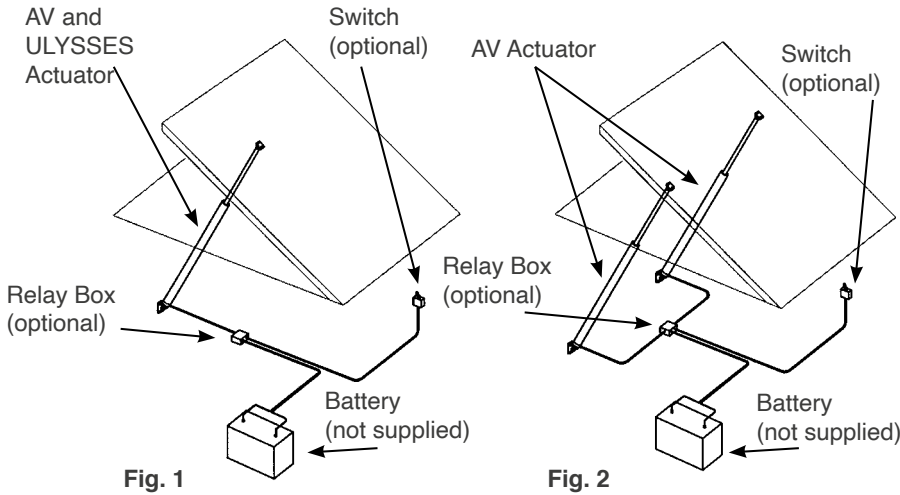

## COMPONENTS DESCRIPTION

### AV Series Hatch Lifter

- n° 1 AV actuator for single installation (Fig.1)
- n° 2 AV actuators for dual installation (Fig.2)
- External diameter: 48 mm (1.9" )
- Maximum oscillation range: 125°

### ULYSSES Series actuators

- n° 1 Ulysses actuator (Fig.1)
- **no dual installatio**
- External diameter: 34 mm (1.3")
- Maximum oscillation range: 180°

### Power supply cable:

- **AV** and **ULYSSES** actuators are supplied with 5 ft (1,5 m) of electrical cable
- Warning: in case of longer cable length required, do not substitute the existing harness, but make a junction following the instructions supplied with the product.

**Relay Box:** 12-24V (on demand)

**Two way push-button** with central off position (optional)

**Fuse** (not supplied)

**Battery** (not supplied)

## INSTALLATION

- The following equation will help you to calculate the maximum strength (Fmax) required from the hatch lifter to open your hatch, knowing the dimensions and weight of the hatch and the position of the mounting brackets.

$$F_{max} = \frac{P}{2} \times \frac{L}{b} \times \frac{X}{a} \times K^*$$

P= hatch weight in N  
L/b/X/a= mm

### Maximum load (Fmax):

#### • AV Series actuators:

1200 N (120 kg - 265 lbs) single installation, pushing only 2400 N (240 kg - 530 lbs) dual installation pushing only

**Note:** when the load exceeds 2400 N (240 kg - 530 lbs), it is possible to install more then two AV actuators. Please, contact our Technical Service for the proper electrical configuration

#### • ULYSSES actuators:

650 N (65 kg - 144 lbs) single installation only, both pull and push

\*Values of K with ratio included between approx. 0 and 0.5 (if ratio > 0.5 use K=1)

		b/d															
		0.1	0.15	0.2	0.3	0.4	0.5	1.0	2.0	3.0	4.0	5.0	6.0	7.0	8.0	9.0	10.0
c/a	0.0	1.09	1.14	1.17	1.24	1.30	1.34	1.41	1.34	1.26	1.21	1.17	1.15	1.13	1.11	1.10	1.09
	0.1	1.00	1.01	1.04	1.09	1.13	1.16	1.23	1.16	1.10	1.06	1.04	1.02	1.01	1.00	1.00	1.00
	0.2	1.00	1.00	1.00	1.03	1.06	1.10	1.16	1.10	1.04	1.01	1.00	1.00	1.00	1.00	1.00	1.00
	0.3	1.00	1.00	1.00	1.00	1.03	1.06	1.12	1.06	1.26	1.01	1.00	1.00	1.00	1.00	1.00	1.00
	0.4	1.00	1.00	1.00	1.00	1.00	1.03	1.10	1.03	1.00	1.00	1.00	1.00	1.00	1.00	1.00	1.00
	0.5	1.00	1.00	1.00	1.00	1.00	1.01	1.08	1.01	1.00	1.00	1.00	1.00	1.00	1.00	1.00	1.00

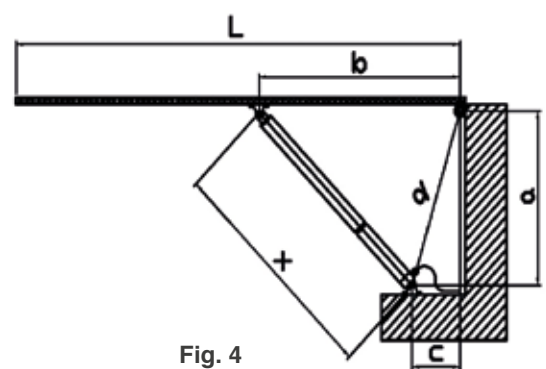
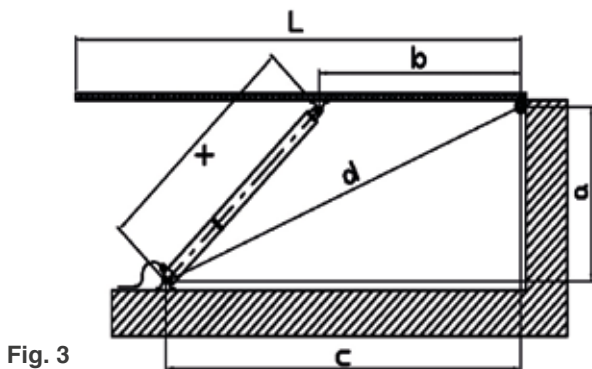



## TRIM TABS - INNOVATIVE FINGERTIP JOYSTICK CONTROL

Boats often become unbalanced to port or starboard due to wind, sea conditions, and weight transfer within the boat.

The innovative joystick by Uflex takes all the guesswork out of realigning the boat. A simple push of the joystick lever in the opposite direction of the "lean" of the boat is all you need to do.

Gone are the days of having to think about the current positions of the tabs and then push two rocker switches, hoping that you have the correct sequence, i.e. port up and starboard down or vice versa.

The Uflex joystick let's you drive like a pro!

- Makes adjusting the position of the boat more intuitive than traditional rocker switches
- Both trim actuators move simultaneously in opposite directions when pushing the joystick to port or to starboard

### REALIGNING LEAN TO PORT OR STARBOARD

Because the joystick simultaneously activates both tabs in opposite directions when adjusting for a lean to port or starboard, the realignment of the boat occurs very quickly, and with optimal tab positioning in terms of efficiency.

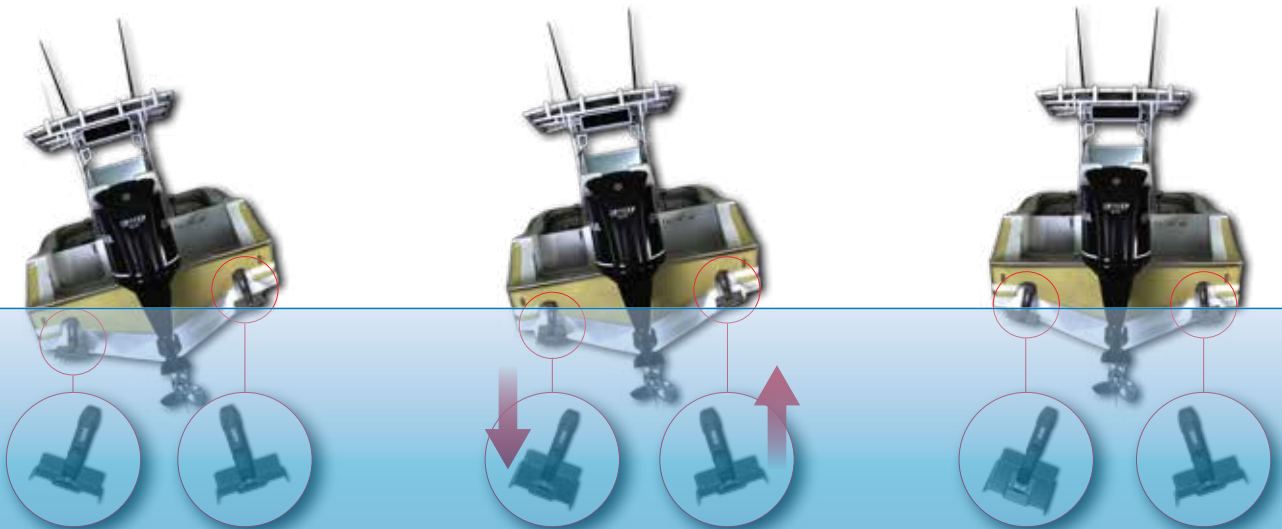

## TRIM TABS - INNOVATIVE FINGERTIP JOYSTICK CONTROL

The unique profile of the Uflex planes offers greater efficiency and stern lift than traditional flat planes, often providing the opportunity to use a smaller size tab with the same performance of a larger flat plane.

- Keep the boat on plane with lower engine RPM

IP68-rated, triple sealed 12VDC electrical mechanical actuators provide:

- One-piece actuator housing reduces the possibility of water intrusion
- Exclusive rubber boot protects internal primary seals from sea growth and high-pressure water

- Planetary gear actuator gearbox provides high efficiency and low amp consumption
- Tempered stainless-steel trapezoidal screw gives peak resistance to impact and high-torque loads
- The actuator upper bracket is prepared to route electrical cable through the transom

### REALIGNING BOW LIFT

Pushing the joystick up or down moves the tabs in the same direction. This changes the attitude of the boat bow up or down.

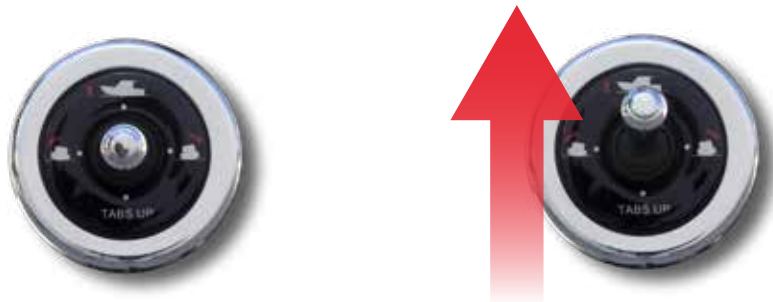



# ELECTROMECHANICAL TRIM TAB SYSTEMS

Improve fuel economy and passenger comfort with Uflex electromechanical trim tabs. Featuring electropolished stainless steel planes and low consumption, high speed, composite actuators, these tabs are built to last in the most demanding sea conditions. Uflex trim tabs have been specifically designed for easy installation using a quick connect bracket-actuator, requiring only one small hole per tab through the transom. The patented transom mounting bracket encapsulates the wiring to ensure protection against any wiring damage.

Uflex trim tab systems are available in 2 versions:

**MTT systems for standard installations**

**MTC systems for compact installations**

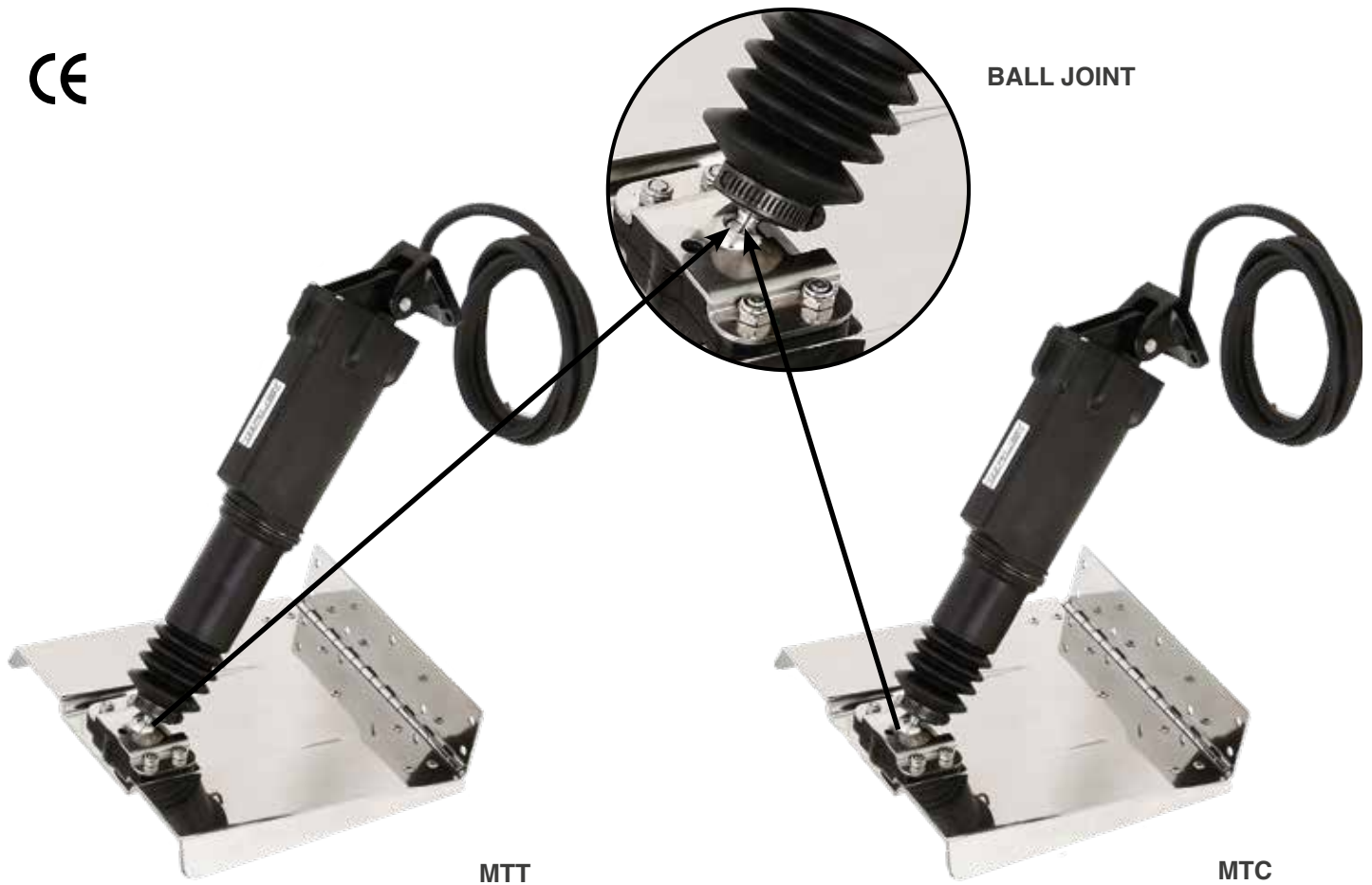

## MTT AND MTC SYSTEMS - FEATURES

- Tab bracket with **BALL JOINT**
- Operating system with hardened steel ballscrew, suitable to withstand high push loads.
- Prompt and easy control with the innovative use of a Joystick (patented)
- **AUTO-LINE UP**: automatic flap re-alignment function
- Completely sealed thermoplastic resin tab actuators: maximum protection guaranteed by dual seals and a rubber bellow (patented)
- Stainless steel rod and tabs
- The innovative profile of the tabs increases the efficiency of the system
- Non polished stainless steel tabs also available (standard tabs only).
- The stainless steel top surface of the tabs is mirror polished to give higher resistance to marine environment.
- Hole hinge design (patented) allows for precise retrofit replacement with Lenco® and Bennett® same size tabs
- Fully maintenance free
- Voltage: 12V DC
- Waterproof: IP68 protection
- CE Certification
- Meets with the EN 60945 standards

# ELECTROMECHANICAL TRIM TAB SYSTEMS

## TRIM TABS COMPONENTS

1	Actuator
2	Connection bracket to the transom
3	Electrical cable (2 m - 6.6 ft)
4	Connection bracket to the tab
5	Tab + hinge
6	Joystick - Control system

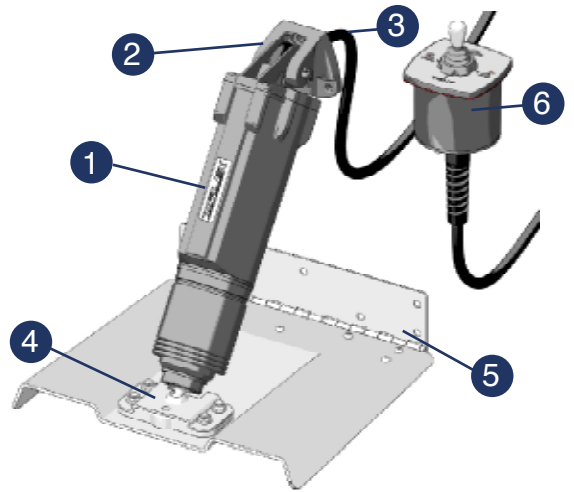

## OPERATION

The **joystick** allows an easy use of the Trim Tab system. Thanks to this control system, the user can focus on the boat trim, regardless of the tab position.

The **electromechanical actuators (2)** that allow changing the **inclination angle of tab (3)** are controlled by means of the **joystick (1)** that is located on the dashboard or on the fly-bridge.

Joystick function description:

- By jogging the lever forward, the boat bow goes down;
- By jogging the lever backward, the boat bow goes up;
- By jogging the lever rightward, the boat tilts to starboard
- By jogging the lever leftward, the boat tilts to port

When running at idle or when the engine turns off, the electronic system enables the **AUTO LINE-UP** function automatically. It allows putting the tabs in rest position.

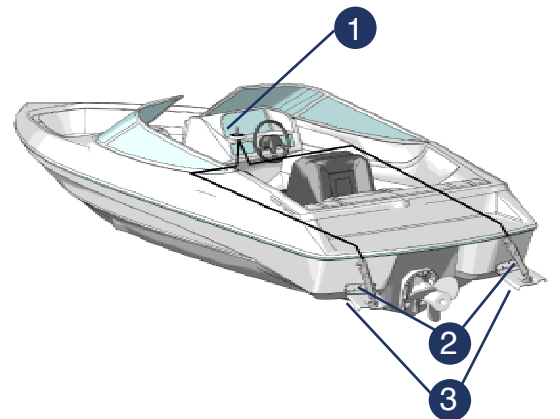

# APPLICATIONS

## MTT INSTALLATION

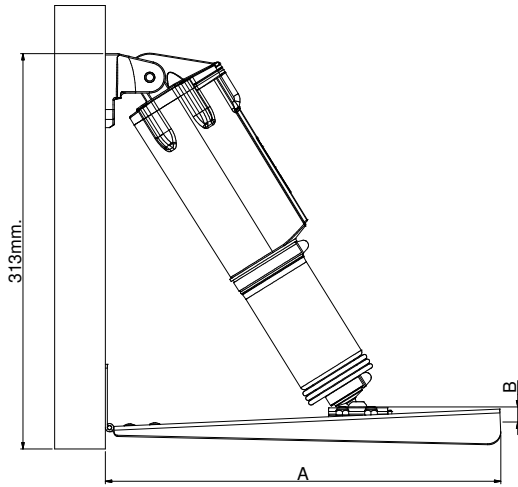

A: 228.6 mm - 9"  
B: 19.5 mm - 0.77"

## MTC TILTED INSTALLATION

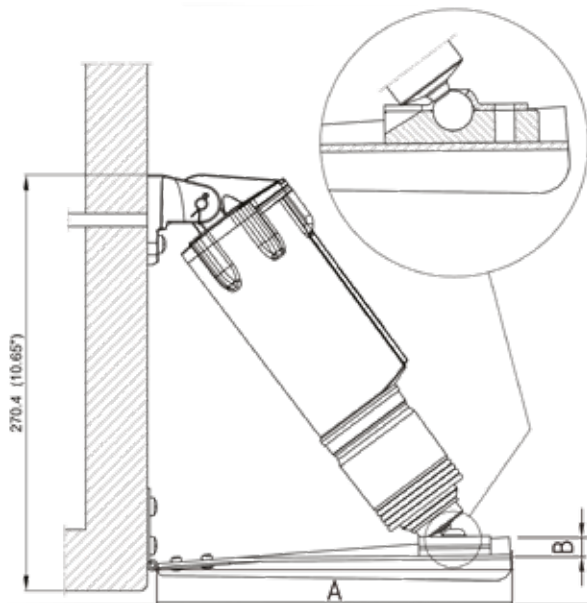

A: 228.6 mm - 9"  
B: 19.5 mm - 0.77"

## MTC VERTICAL INSTALLATION

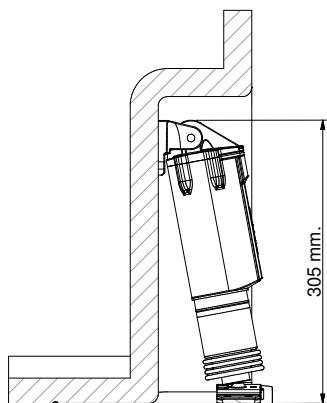

**NOTE:** dimensions could change in case of raked transom

## MTT SYSTEMS - APPLICATION

BOAT LENGTH	BOAT LENGTH (m)	TAB SIZE L x I (")	TAB SIZE L x I (cm)	TRANSOM MINIMUM HEIGHT
14' - 18'	4,5 - 5,5	9" x 9"	22,8 x 22,8	31.03 cm (12.22")
16' - 25'	5,0 - 8,0	12"x 9"	30,5 x 22,8	31.03 cm (12.22")
18' - 30'	5,5 - 9,0	12" x 12"	30,5 x 30,5	31.03 cm (12.22")
26' - 36'	8,0 - 11,0	12" x 18"	30,5 x 45,7	31.03 cm (12.22")

## MTC SYSTEMS - APPLICATION

BOAT LENGTH	BOAT LENGTH (m)	TAB SIZE L x I (")	TAB SIZE L x I (cm)	TRANSOM MINIMUM HEIGHT	
				TILTED INSTALLATION	VERTICAL INSTALLATION
14' - 18'	4,5 - 5,5	9" x 9"	22,8 x 22,8	27.04 cm (10.65")	30.5 cm (12")
16' - 25'	5,0 - 8,0	12"x 9"	30,5 x 22,8	27.04 cm (10.65")	30.5 cm (12")
18' - 30'	5,5 - 9,0	12" x 12"	30,5 x 30,5	27.04 cm (10.65")	30.5 cm (12")
26' - 36'	8,0 - 11,0	12" x 18"	30,5 x 45,7	27.04 cm (10.65")	30.5 cm (12")

**NOTE:** L= Tab length, I= Transom side.

These recommendations should be used as a general reference only. Final selection should be made with the assistance of a qualified installation technician. For any further information please contact our Technical Service

**WARNING:** The systems are not intended for use in racing applications

## STANDARD COMPONENTS (SINGLE ACTUATOR PER TAB)

- 1 pair of electromechanical actuator complete with connection brackets and 2 m (6.56') wiring harness.
- 1 joystick control unit with 0.50 m (1.64') wiring harness
- 1 pair of stainless steel tabs. Tabs are sold separately: specify selected size when ordering

## OPTIONAL COMPONENTS

- 1 extension wiring harness kit for the power cable and the actuator cables. Deutsch plugs included
- 1 second station joystick-2 control unit with 0.50 m (1.64') wiring harness
- 1 extension wiring harness (6 m and 9 m for second station). Deutsch plugs included.
- 1 extension wiring harness (2 m for auto-line up). Deutsch plugs included.
- 1 zinc alloy sacrificial anode kit to neutralize the galvanic currents on tabs ( 2 anode kits for every 1 pair tab installation)

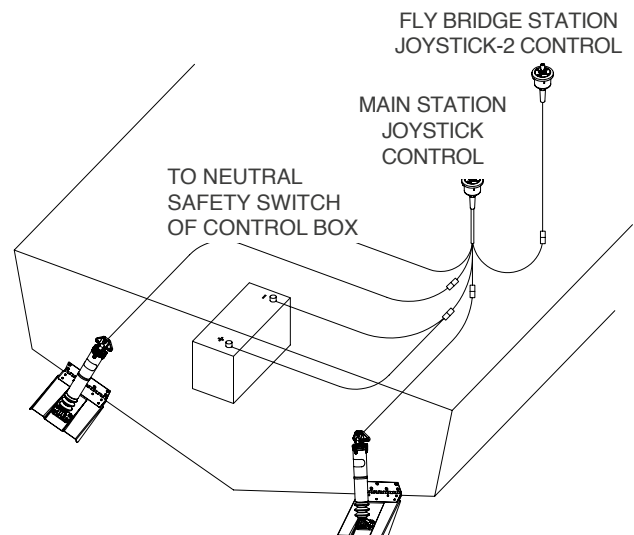

# ACTUATORS



AT12 - 43160S



AC12 - 43001V

## FEATURES

- 12 VDC Black actuator and brackets
- 1 m (3.28') wiring harness with Deutsch crimped pins included
- Stroke: 57 mm (2.25")

## AT ACTUATOR FULL CLOSED/OPEN

- A** = 309 mm (12.17")
- B** = 366 mm (14.41")
- C** = 83 mm (3.27")

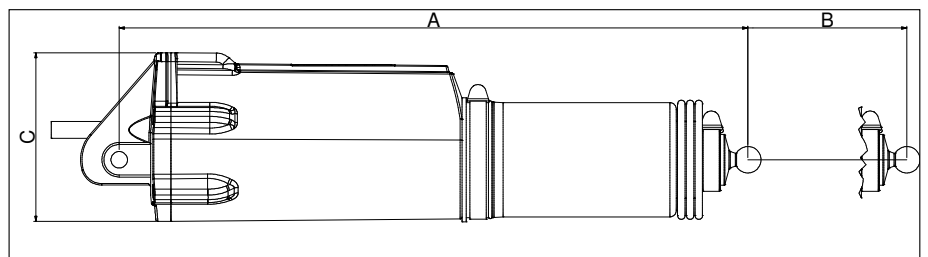

## AC ACTUATOR FULL CLOSED/OPEN

- A** = 273 mm (10.75")
- B** = 330 mm (13")
- C** = 83 mm (3.27")

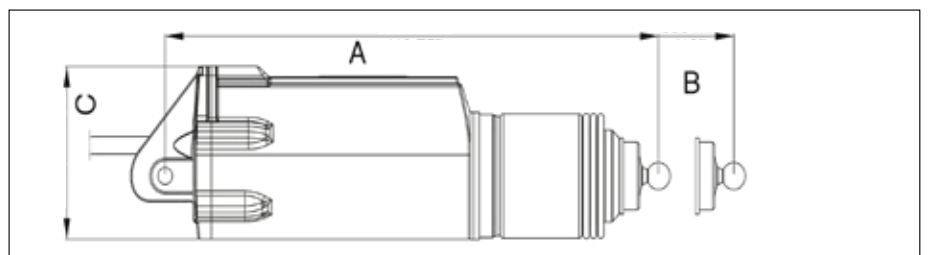

# JOYSTICK CONTROL UNITS FOR SINGLE AND DUAL STATION



J/CH



JLP/CH



J/B-LED



JLP/B

J/B

Black finish (optional)

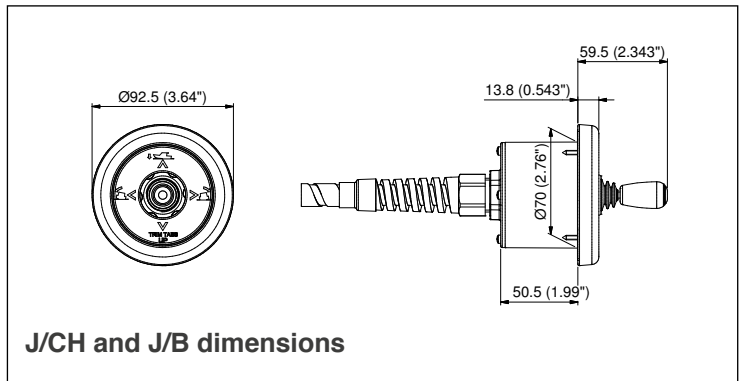

J/CH and J/B dimensions

## JOYSTICK CONTROL UNITS FOR SINGLE STATION:

J/CH - 41849Z chrome

J/B - 42855Z black (optional)

JLP/CH - 43004B chrome, low profile

JLP/B - 43005D black, low profile (optional)

J/B-LED - 43416B joystick control with LED indicators

- Main station compact control unit with joystick (PATENTED), **auto-line-up** function included (automatic fla re-alignment)
- 0.50 m (1.64") wiring harness included
- 70 mm (2.76") hole size
- Retrofit installation is also available on systems with standard joystick controls

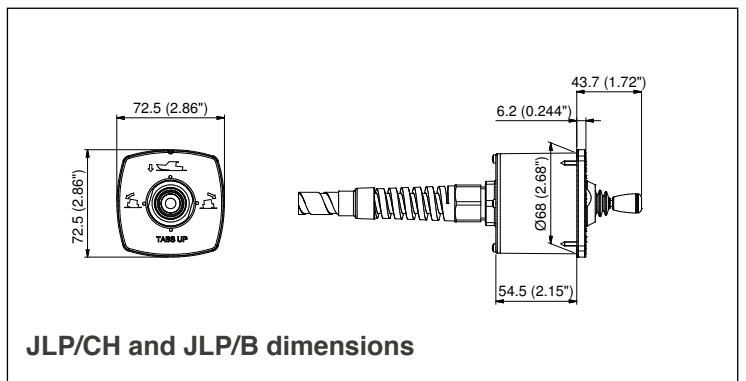

JLP/CH and JLP/B dimensions

## JOYSTICK CONTROL UNITS FOR DUAL STATION:

J/CH-2 - 42306 N chrome

J/B-2 - 42856 B black (optional)

JLP/CH-2 - 43080 U chrome, low profile

JLP/B-2 - 43081 W black, low profile (optional)

- 70 mm (2.76") hole size
- 6 m and 9 m (19.7' and 29.6') extension wiring harness available with deutsch plugs included (optional)

J/B-LED - 43416B joystick control with LED indicators

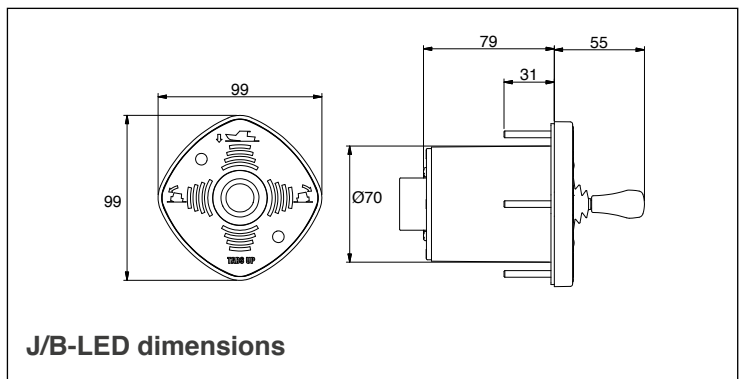

J/B-LED dimensions

NOTE: it is not possible to install a joystick control unit with LED and without LED in the same system



## STANDARD NON POLISHED TABS

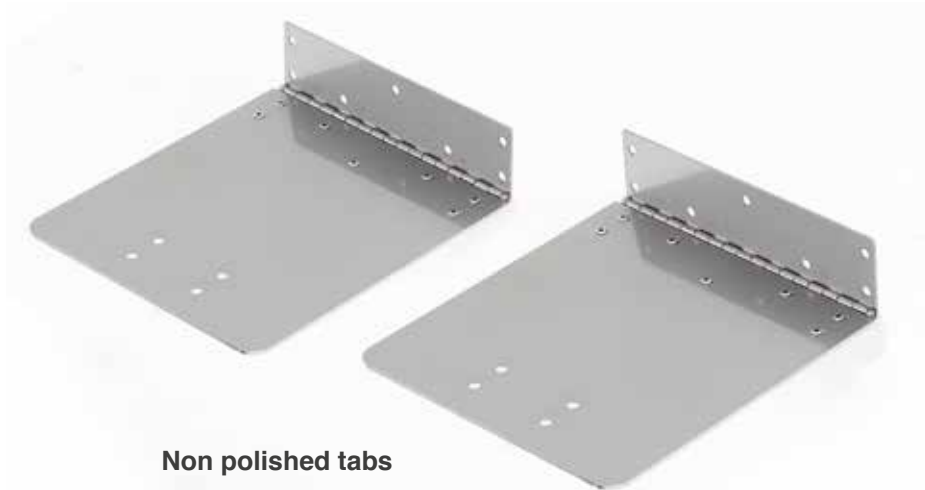

**Non polished tabs**

No need for new holes in case of Lenco® or Bennett® same size replacements.  
They are not designed for use in racing applications.

MODEL	PART No.	DESCRIPTION	WEIGHT PER PAIR
NP99	42650E	Stainless steel tab pair 228,6 x 228,6 mm (9"x9")	3,3 kg (7.3 lbs)
NP129	42653L	Stainless steel tab pair 304,8 x 228,6 mm (12"x9")	4,0 kg (8.8 lbs)
NP1212	42651G	Stainless steel tab pair 304,8 x 304,8 mm (12"x12")	5,0 kg (11.0 lbs)
NP1218	42652J	Stainless steel tab pair 304,8 x 457,2 mm (12"x18")	7,4 kg (16.3 lbs)

## STAINLESS STEEL EDGE MOUNT TABS



**Stainless steel edge mount tabs**

Stainless steel non polished trim tabs blades.  
No need for new holes in case of Lenco® or Bennett® same size replacements.  
The installation requires less transom height than standard and high performance blades.  
They are not designed for use in racing applications.

MODEL	PART No.	DESCRIPTION	WEIGHT PER PAIR
NPE912	43630D	Stainless steel tab pair 228,6 x 304,8 mm (9"x12")	5,8 kg (12.8 lbs)
NPE129	43631F	Stainless steel tab pair 304,8 x 228,6 mm (12"x9")	5,6 kg (12.3 lbs)
NPE1212	43632H	Stainless steel tab pair 304,8 x 304,8 mm (12"x12")	7,2 kg (15.9 lbs)
NPE1218	43633K	Stainless steel tab pair 304,8 x 457,2 mm (12"x18")	10,8 kg (23.8 lbs)

## HIGH PERFORMANCE POLISHED TABS



**Mirror polished stainless steel tabs**

Stainless steel, mirror electro-polished trim tab blades.  
No need for new holes in case of Lenco® or Bennett® same size replacements.  
They are not designed for use in racing applications.

MODEL	PART No.	DESCRIPTION	WEIGHT PER PAIR
<b>P99</b>	41844N	Stainless steel tab pair 228,6 x 228,6 mm (9"x9")	2,8 kg (6.2 lbs)
<b>P129</b>	41845R	Stainless steel tab pair 304,8 x 228,6 mm (12"x9")	3,6 kg (7.9 lbs)
<b>P1212</b>	41846T	Stainless steel tab pair 304,8 x 304,8 mm (12"x12")	4,6 kg (10.1 lbs)
<b>P1218</b>	41847V	Stainless steel tab pair 304,8 x 457,2 mm (12"x18")	6,7 kg (14.8 lbs)

## OPTIONAL COMPONENTS

**KE20** - 42378R - Extension Wiring Harness. Kit includes one 16.4' (5,0 m) length wiring harness extension for the power cable and two 19.7' (6,0 m) length wiring harness extensions for the actuator cables. Deutsch plugs included.

**KE30** - 42379T - Extension Wiring Harness. Kit includes one 16.4' (5,0 m) length wiring harness extension for the power cable and two 29.5' (9,0 m) length wiring harness extensions for the actuator cables. Deutsch plugs included.

**KEJ2-20** - 41853P - 19.7' (6,0 m) extension wiring harness for a second station. Deutsch connectors included.

**KEJ2-30** - 42375J - 29.5' (9,0 m) extension wiring harness for a second station. Deutsch connectors included.

**KEK-7** - 42376L - 6.6' (2,0 m) auto-line up extension wiring harness key frame. Deutsch connectors included.

**KENS-7** - 42377N - 6.6' (2,0 m) auto-line up extension wiring harness neutral safety. Deutsch connectors included. Not suitable for systems with joystick control with led indicators (J/B-LED).

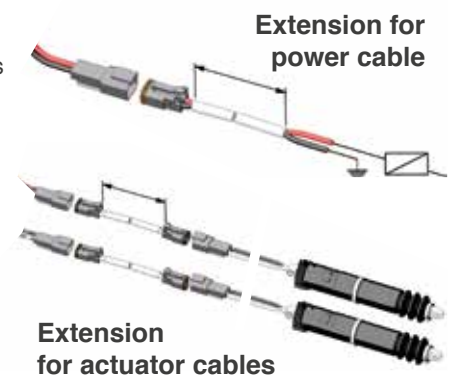

### RETROFIT BRACKET

BRS-T bracket will adapt AT12-AS12 actuator to pre-existing mounting holes on transom, in case of AS12 or of Lenco® replacement (until 2007).

**BRS-T** - 43220H - black bracket



**BRS-T**

### ANODE KIT

Zinc alloy anode kit neutralizes the galvanic currents endangering the trim tabs. 2 anode kits are necessary for every 1 pair tab installation.

**KA70** - 42441V - Ø 2.8" (70 mm) sacrificial anode kit for tab up to 12" x 12" size

**KA90** - 42442X - Ø 3.5" (90 mm) sacrificial anode kit for tab 12" x 18" size



**KA70**

**KA90**

# PACKAGED UFLEX TRIM TAB SET

The prepackaged UFLEX set includes 1 pair of actuators complete with brackets and 1 joystick. The tabs are not included and sold separately: selected model has to be specified when ordering.

Not intended for use in racing applications.

CE Certification  
Waterproof: IP68  
EN60945 Certification



MODEL	PART No.	VOLT	DESCRIPTION
MTT 12-CH	43250T	12V DC	2 AT12 actuators, 12V DC + 1 chrome joystick
MTT 12-CH-LP	43251V	12V DC	2 AT12 actuators, 12V DC + 1 chrome low profile joystick
MTC 12-CH	43043M	12V DC	2 AC12 actuators, 12V DC + 1 chrome joystick
MTC 12-CH-LP	43044P	12V DC	2 AC12 actuators, 12V DC + 1 chrome low profile joystick

## SPARE PARTS

MODEL	PART No.	DESCRIPTION
BRS-C	43039X	Bracket kit - Connection between AT or AC actuators and boat
BRT-C	43040F	Bracket kit - Connection between AT or AC actuators and tab
EP 5	42440T	Wiring harness extension for power cable 5,0 m (16.4')
EP 6	42302E	Wiring harness extension for actuator cable 6,0 m (19.7')
EP 9	42439J	Wiring harness extension for actuator cable 9,0 m (29.5')

## CROSS MATCH SPARE PARTS VS ACTUATORS

ACTUATOR PART No.	BELLOWS KIT PART No.	BRACKET KIT PART No. (TAB SIDE)	BRACKET KIT PART No. (TRANSOM SIDE)
41839W	43094F	42296N	42298T
42937B	43094F	42296N	42298T
43001V	43724N	43040F	43039X / 43220H (Retrofit)*
43160S	43725R	43040F	43039X / 43220H (Retrofit)*
43276M	43724N	43040F	43220H
43280C	43094F	42296N	42298T
43302K	43725R	43040F	43220H
43432Z	43724N	43040F	43039X
43507E	43725R	43040F	43220H
42608F	43094F	42296N	42298T
43272D	43724N	43040F	43220H

\* Part No. 43220H - see retrofit bracket explanation

# VELAIR



# VSD INVERTER DRIVEN SELF-CONTAINED AIR CONDITIONING SYSTEMS REVERSE CYCLE FUNCTION

VELAIR



## VARIABLE SPEED DRIVE



VELAIR APP



Self-contained-VSD air conditioners provides the best of the existing technology: Twin Rotary compressor with brushless DC motor and inverter that constantly controls speed and delivered cooling power (Variable Speed Drive); Constant Flow brushless fan (only i10 and i16); electronic expansion valve; R32 refrigerant..

Available in three sizes: 10.000, 16.000 and 21.000 BTU/h max output.

The inverter technology, already used in residential air-conditioning, offers the following **benefits** in marine applications:

- No current peaks during start-up
- Highest energy efficiency: overall reduction of electricity consumption (-40%)
- Perfectly running with small generators or battery powered (through inverter)
- Compressor noise and vibrations almost zero
- Constant temperature of the air flow
- Wi-fi connection for smartphone available through a dedicated app
- Heat pump reverse cycle operation to heat the environment in winter
- Constant Flow technology fan (only i10 and i16)



Compact i10 VSD SMART

The compressor continuously changes its running speed depending from ambient and set temperature. The compressor operates at maximum power to cool rapidly the cabins, but reaching the set temperature, it reduces the power and electric consumption. In this way it maintains the optimal comfort level with the minimum consumption. The inverter works between 20 and 100 Hz.

Self-contained-VSD VELAIR units meet EMC 2004/108/EC directives.

## TECHNICAL SPECIFICATIONS

MODEL	Compact i10 VSD SMART	Compact i16 VSD SMART	Compact i21 VSD
230V - 50/60 Hz Part No.	24831GW	24832JW	24765WW
115V - 50/60 Hz Part No.	24831GU	24832JU	-
Cooling capacity range	4000 - 10000 BTU/h	6500 - 16000 BTU/h	7000 - 21000 BTU/h
Power supply voltage	1 PH 230V - 50/60 Hz 1 PH 115V - 50/60 Hz	1 PH 230V - 50/60 Hz 1 PH 115V - 50/60 Hz	1 PH 230V - 50/60 Hz
Power consumption cooling (max)	2.9 A @230 V 6.0 A @115 V	4.1 A @230 V 8.5 A @115 V	6.1 A @230 V
Protection	10 A (230/115V)	10 A (230/115V)	10 A
Cable size (min)	2,5 mm <sup>2</sup> (230V) - 4 mm <sup>2</sup> (115V)	2,5 mm <sup>2</sup> (230V) - 4 mm <sup>2</sup> (115V)	4 mm <sup>2</sup> (230V)
Max air flow	400 m <sup>3</sup> /h	550 m <sup>3</sup> /h	800 m <sup>3</sup> /h
Air exit duct (for max capacity)	1 x Ø 100 mm - 1 x Ø 3.9"	1 x Ø 125 mm - 1 x Ø 4.9"	3 x Ø 152 mm - 3 x Ø 6"
Min. opening for return air grill	400 cm <sup>2</sup>	600 cm <sup>2</sup>	800 cm <sup>2</sup>
Min. opening for supply air grill (recommended)	250 cm <sup>2</sup>	300 cm <sup>2</sup>	400 cm <sup>2</sup>
Min. seawater flow rate	12 l/min	15 l/min	20 l/min
Dimensions WxHxD mm (")	571x320x323* (22.5x12.6x12.7)	650x330x355* (25.6x13x14)	730x445x323* (28.7x17.5x12.7)
Weight kg (lbs)	25 (55.1)	28 (61.7)	40 (88.2)

\*Measures including electric panel

CONTROL PANEL

The units are supplied with a wall-mounted touch control digital panel, easy to install as, being very thin, it can be applied on the wall itself, without the classic rectangular cut. A simple round hole is enough to pass the data cable.

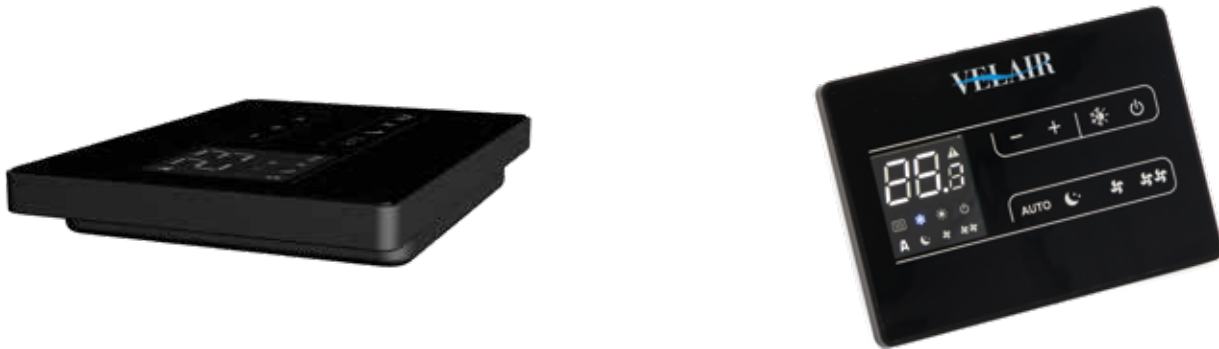

ELECTRIC CONTROL BOX

The units are extremely easy to install thanks to the prewired electrical box with a cable bundle that allows the optimal positioning around the machine itself. Unlocking the four screws, it's possible to access directly to the terminal block to connect the power supply and the sea water pump.

VSD UNIT NEW OPTIONAL CONTROL PANEL

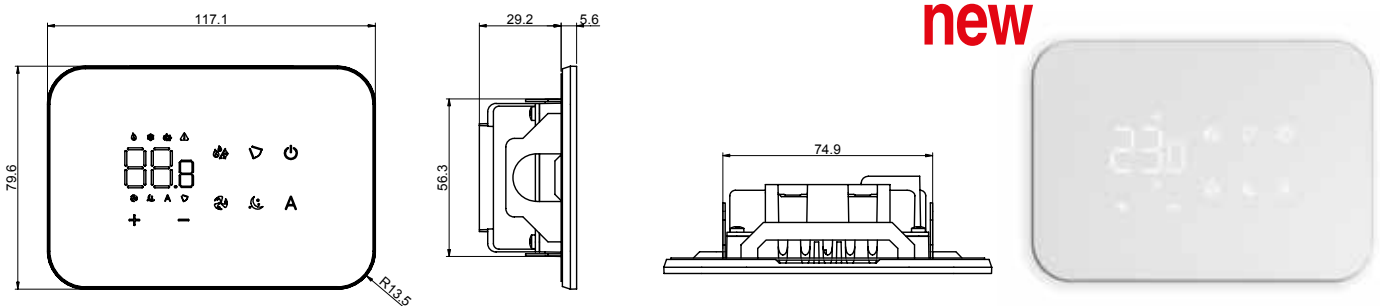

**SMART M7-Touch control panel code 25829B**

- New SMART M7-Touch control panel, available as an Optional for VSD Smart i10/i16, and VSD i21 compact air conditioners
- Can be installed as a refit on already assembled units, or on new installation as an alternative to the standard control panel supplied
  - Led electronic control with Touch interface
  - Elegant Design / Ultrathin
  - Magnetic installation frame on 503 box template, no connection screws to the panel





## VELAIR APP

A Wi-Fi module has been introduced into the panel. This function allows to reach, monitor and set-up your unit through a dedicated app. When you are on board, the smartphone will speak directly with the unit. When away from the boat, the communication will take place through internet, therefore a wi-fi network in the marina or a router on board is required. This allows to turn on the air conditioning or heat pump in advance, in order to arrive on board finding the cabins at a comfortable temperature and humidity level.

A free app is available for IOS and Android Store



**NOTE:** Available upon request seawater centrifugal pumps and accessories for air conditioning systems (Air ducting, air conditioning grates etc.)







## NOTE